

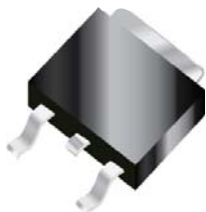

Excellent Schottky Barrier Rectifiers



D2-PAK

Primary Characteristics		
I_F	30	A
V_{RRM}	200	V
I_{FSM}	200	A
V_F	0.88	V
$T_J \text{ max}$	150	°C

Features
<ul style="list-style-type: none"> • Low Forward Voltage Drop • Excellent High Temperature Stability • Excellent Barrier Rectifier Technology • Soft, Fast Switching Capability

Mechanical Data
<ul style="list-style-type: none"> • Case: D2-PAK • Case Material: Molded Plastic, UL Flammability Classification Rating 94V-0 • Terminals: Matte Tin Finish annealed over Copper leadframe. Solderable per MIL-STD-202, Method 208 • Weight: 1.43 grams (approximate)

Ordering Information			
Part No.	Remark	Package	Packing
EBRT30L200CD2	General	D2-PAK	800 / Reel
EBRT30L200CD2-H	Halogen Free		

Maximum Ratings (TA=25°C unless otherwise noted)			
PARAMETER	SYMBOL	EBRT30L200CD2	UNIT
Maximum repetitive peak reverse voltage	V_{RRM}	200	V
Maximum RMS voltage	V_{RMS}	140	V
Maximum DC blocking voltage	V_{DC}	200	V
Maximum average forward rectified current (Total)	I_F	30	A
(Per Leg)		15	
Peak forward surge current, 8.3ms single half sine-wave superimposed on rated load	I_{FSM}	200	A
Maximum Instantaneous Forward Voltage IF=3A @ 25°C IF=15A @ 25°C	V_F	0.65 Typ. 0.88 Max.	V
Maximum DC Reverse Current @ TA=25°C at Rated DC Blocking Voltage @ TA=125°C	I_R	0.2 25	mA
Typical Junction Capacitance(NOTE1)	C_j	1100	pF
Typical Thermal Resistance	$R_{\theta JC}$	3	°C/W
Operating Temperature Range	T_J	-55 to +150	°C
Storage Temperature Range	T_{STG}	-55 to +175	°C
Marking Code		30L200CD2 · T30L200CD2	

NOTES:

1. Measured at 1.0MHZ and applied reverse voltage of 4.0V DC



Excellent Schottky Barrier Rectifiers

Rating and Characteristics Curves

FIG. 1-Typical Forward Current Derating Curve

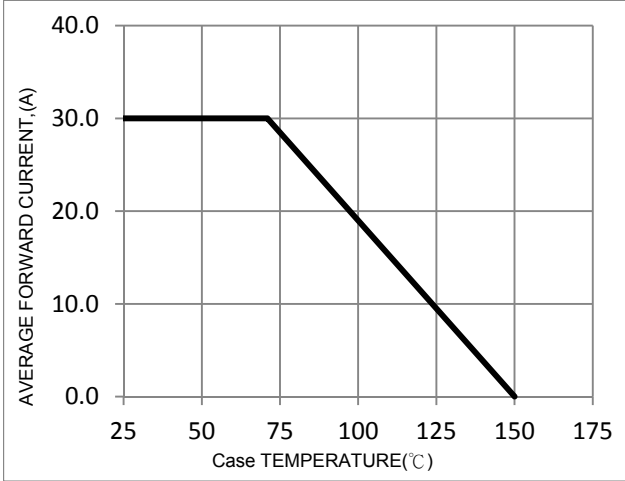

FIG. 2-Typical Forward Characteristics

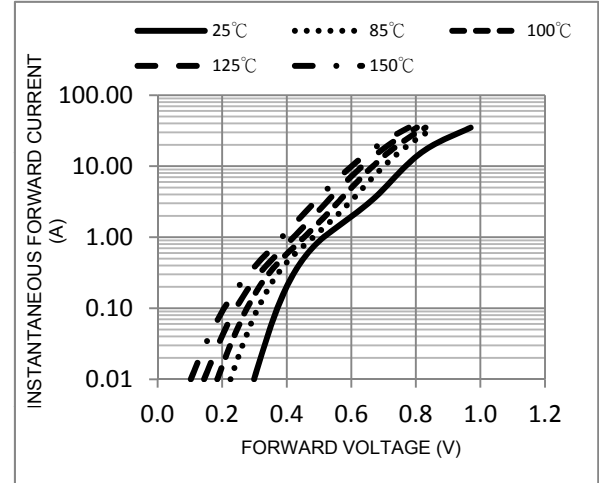

FIG. 3-Maximum Non-Repetitive Forward Surge Current

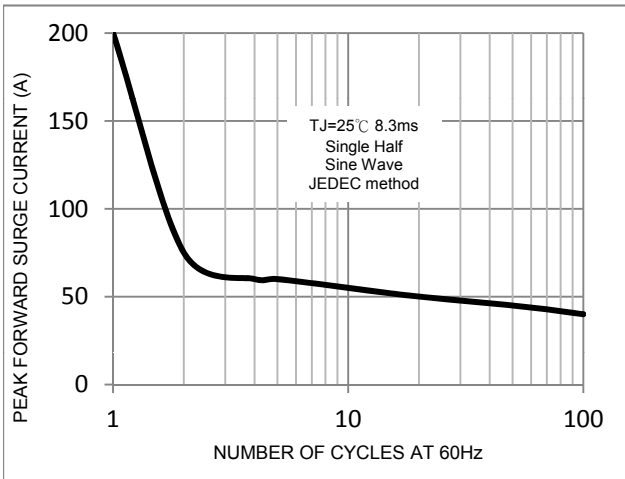

FIG. 4-Typical Reverse Characteristics

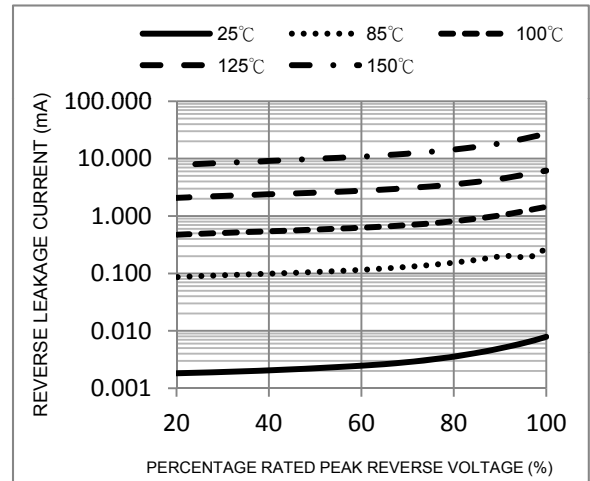
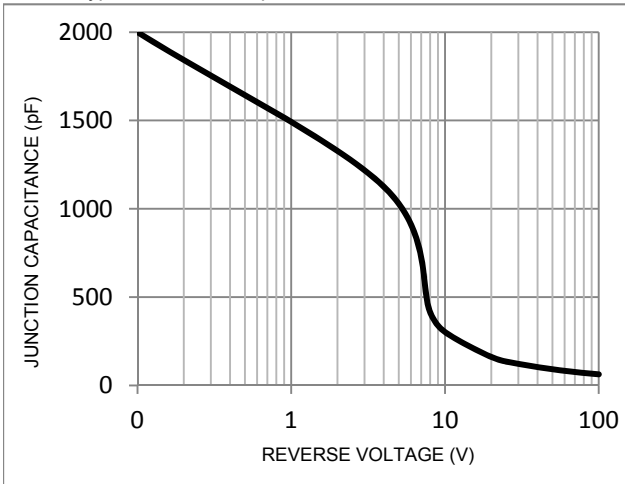

FIG. 5-Typical Junction Capacitance





Excellent Schottky
Barrier Rectifiers

Package Outline Dimensions

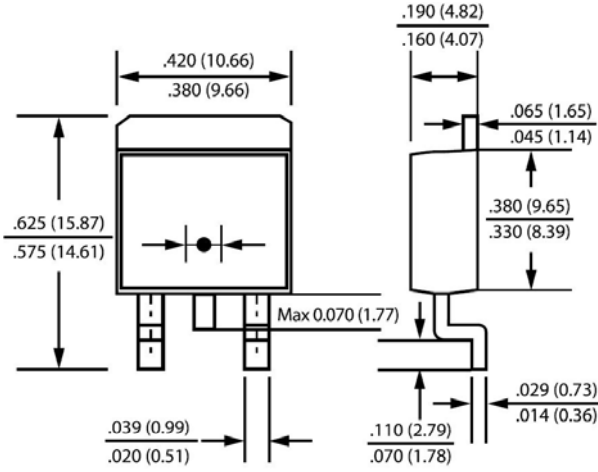

D2-PAK

Dimensions in inches and (millimeters)

Marking Information

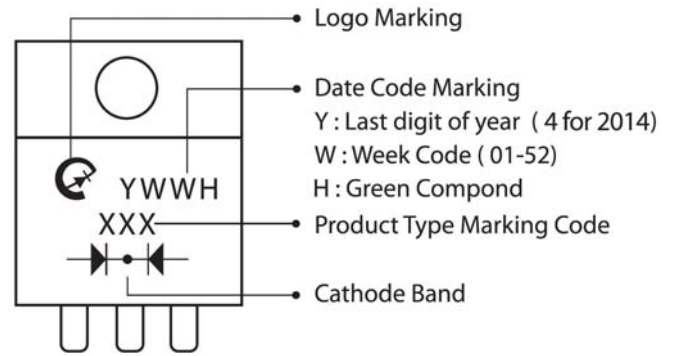

Suggested Pad Layout

Dimension	Outline	D2PAK (mm)
A		5.08
B		1.10
C		10.80
D		8.30
E		3.50
F		16.90

