



# GD25LF128E

# DATASHEET



## Contents

<b>1</b>	<b>FEATURES .....</b>	<b>4</b>
<b>2</b>	<b>GENERAL DESCRIPTIONS.....</b>	<b>5</b>
<b>3</b>	<b>MEMORY ORGANIZATION.....</b>	<b>9</b>
<b>4</b>	<b>DEVICE OPERATIONS.....</b>	<b>10</b>
4.1	SPI MODE .....	10
4.2	QPI MODE.....	10
4.3	RESET FUNCTION .....	10
<b>5</b>	<b>DATA PROTECTION.....</b>	<b>12</b>
<b>6</b>	<b>STATUS REGISTER .....</b>	<b>14</b>
<b>7</b>	<b>COMMAND DESCRIPTIONS .....</b>	<b>17</b>
7.1	WRITE ENABLE (WREN) (06H).....	21
7.2	WRITE DISABLE (WRDI) (04H) .....	21
7.3	READ STATUS REGISTER (RDSR) (05H/35H/15H).....	22
7.4	WRITE STATUS REGISTER (WRSR) (01H/11H) .....	22
7.5	WRITE ENABLE FOR VOLATILE STATUS REGISTER (50H) .....	23
7.6	READ DATA BYTES (READ) (03H).....	24
7.7	READ DATA BYTES AT HIGHER SPEED (FAST READ) (0BH).....	24
7.8	DUAL OUTPUT FAST READ (3BH).....	25
7.9	QUAD OUTPUT FAST READ (6BH) .....	26
7.10	DUAL I/O FAST READ (BBH) .....	27
7.11	QUAD I/O FAST READ (EBH) .....	28
7.12	BURST READ WITH WRAP (0CH).....	30
7.13	DTR QUAD I/O FAST READ (DTRQIO) (EDH).....	30
7.14	SET BURST WITH WRAP (77H) .....	31
7.15	SET READ PARAMETERS (COH) .....	32
7.16	PAGE PROGRAM (PP) (02H).....	33
7.17	QUAD PAGE PROGRAM (32H).....	33
7.18	SECTOR ERASE (SE) (20H).....	34
7.19	32KB BLOCK ERASE (BE32) (52H).....	35
7.20	64KB BLOCK ERASE (BE64) (D8H).....	36
7.21	CHIP ERASE (CE) (60H/C7H) .....	36
7.22	READ MANUFACTURE ID/ DEVICE ID (REMS) (90H) .....	37
7.23	READ IDENTIFICATION (RDID) (9FH).....	38
7.24	READ UNIQUE ID (4BH).....	39
7.25	ERASE SECURITY REGISTERS (44H) .....	39
7.26	PROGRAM SECURITY REGISTERS (42H).....	40



7.27	READ SECURITY REGISTERS (48H) .....	40
7.28	ENABLE RESET (66H) AND RESET (99H) .....	41
7.29	PROGRAM/ERASE SUSPEND (PES) (75H) .....	42
7.30	PROGRAM/ERASE RESUME (PER) (7AH) .....	43
7.31	DEEP POWER-DOWN (DP) (B9H) .....	43
7.32	RELEASE FROM DEEP POWER-DOWN AND READ DEVICE ID (RDI) (ABH) .....	44
7.33	ENABLE QPI (38H) .....	45
7.34	DISABLE QPI (FFH) .....	46
7.35	READ SERIAL FLASH DISCOVERABLE PARAMETER (5AH).....	46
<b>8</b>	<b>ELECTRICAL CHARACTERISTICS .....</b>	<b>48</b>
8.1	POWER-ON TIMING .....	48
8.2	INITIAL DELIVERY STATE .....	48
8.3	ABSOLUTE MAXIMUM RATINGS .....	48
8.4	CAPACITANCE MEASUREMENT CONDITIONS.....	49
8.5	DC CHARACTERISTICS .....	50
8.6	AC CHARACTERISTICS .....	53
<b>9</b>	<b>ORDERING INFORMATION.....</b>	<b>60</b>
9.1	VALID PART NUMBERS .....	61
<b>10</b>	<b>PACKAGE INFORMATION .....</b>	<b>63</b>
10.1	PACKAGE SOP8 208MIL .....	63
10.2	PACKAGE USON8 (4x4MM) .....	64
10.3	PACKAGE WSON8 (6x5MM) .....	65
10.4	PACKAGE TFBGA-24BALL (5x5 BALL ARRAY).....	66
<b>11</b>	<b>REVISION HISTORY .....</b>	<b>67</b>



## 1 FEATURES

- ◆ 128M-bit Serial Flash
  - 16M-Byte
  - 256 Bytes per programmable page
- ◆ Standard, Dual, Quad SPI, QPI, DTR
  - Standard SPI: SCLK, CS#, SI, SO, RESET#
  - Dual SPI: SCLK, CS#, IO0, IO1, RESET#
  - Quad SPI: SCLK, CS#, IO0, IO1, IO2, IO3, RESET#
  - QPI: SCLK, CS#, IO0, IO1, IO2, IO3, RESET#
  - SPI DTR (Double Transfer Rate) Read
- ◆ High Speed Clock Frequency
  - 166MHz for fast read
  - Dual I/O Data transfer up to 332Mbits/s
  - Quad I/O Data transfer up to 664Mbits/s
  - QPI Mode Data transfer up to 664Mbits/s
  - DTR Quad I/O Data transfer up to 832Mbits/s
- ◆ Software Write Protection
  - Write protect all/portion of memory via software
  - Top/Bottom Block protection
- ◆ Endurance and Data Retention
  - Minimum 100,000 Program/Erase Cycles
  - 20-year data retention typical
- ◆ Allows XiP (eXecute In Place) Operation
  - High speed Read reduce overall XiP instruction fetch time
  - Continuous Read with Wrap further reduce data latency to fill up SoC cache
- ◆ Fast Program/Erase Speed
  - Page Program time: 0.25ms typical
  - Sector Erase time: 30ms typical
  - Block Erase time: 0.1s/0.15s typical
  - Chip Erase time: 32s typical
- ◆ Flexible Architecture
  - Uniform Sector of 4K-Byte
  - Uniform Block of 32/64K-Byte
- ◆ Low Power Consumption
  - 11 $\mu$ A typical standby current
  - 0.2 $\mu$ A typical deep power down current
- ◆ Advanced Security Features
  - 128-bit Unique ID for each device
  - Serial Flash Discoverable parameters (SFDP) register
  - 3x1024-Byte Security Registers With OTP Locks
- ◆ Single Power Supply Voltage
  - Full voltage range: 1.65-2.0V
- ◆ Package Information
  - SOP8 208mil
  - USON8 (4x4mm)
  - WSON8 (6x5mm)
  - TFBGA-24ball (5x5 Ball Array)



## 2 GENERAL DESCRIPTIONS

The GD25LF128E (128M-bit) Serial flash supports the standard Serial Peripheral Interface (SPI), and the Dual/Quad SPI: Serial Clock, Chip Select, Serial Data I/O0 (SI), I/O1 (SO), I/O2, I/O3. The Dual I/O data is transferred with speed of 332Mbit/s, and the Quad I/O data is transferred with speed of 664Mbit/s. The DTR Quad I/O data is transferred with speed of 832Mbits/s.

### CONNECTION DIAGRAM AND PIN DESCRIPTION

**Figure 1 Connection Diagram for SOP8 package**

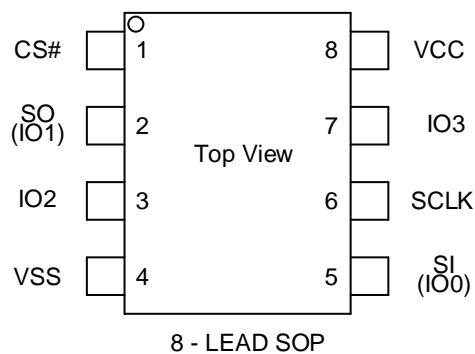

**Table 1. Pin Description for SOP8 Package**

Pin No.	Pin Name	I/O	Description
1	CS#	I	Chip Select Input
2	SO (IO1)	I/O	Data Output (Data Input Output 1)
3	IO2	I/O	Data Input Output 2
4	VSS		Ground
5	SI (IO0)	I/O	Data Input (Data Input Output 0)
6	SCLK	I	Serial Clock Input
7	IO3	I/O	Data Input Output 3
8	VCC		Power Supply

Note:

1. CS# must be driven high if chip is not selected. Please don't leave CS# floating any time after power is on.
2. If IO2/IO3 is unused, it must be driven high by the host, or an external pull-up resistor must be placed on the PCB in order to avoid allowing IO2/IO3 input to float.



**Figure 2 Connection Diagram for USON8/WSON8 package**

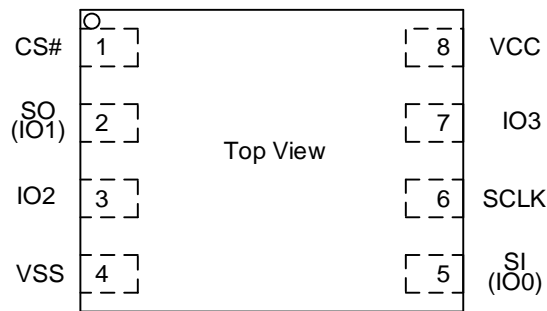

8 - LEAD USON/WSON

**Table 2. Pin Description for USON8/WSON8 Package**

Pin No.	Pin Name	I/O	Description
1	CS#	I	Chip Select Input
2	SO (IO1)	I/O	Data Output (Data Input Output 1)
3	IO2	I/O	Data Input Output 2
4	VSS		Ground
5	SI (IO0)	I/O	Data Input (Data Input Output 0)
6	SCLK	I	Serial Clock Input
7	IO3	I/O	Data Input Output 3
8	VCC		Power Supply

**Note:**

1. CS# must be driven high if chip is not selected. Please don't leave CS# floating any time after power is on.
2. If IO2/IO3 is unused, it must be driven high by the host, or an external pull-up resistor must be placed on the PCB in order to avoid allowing IO2/IO3 input to float.

Figure 3 Connection Diagram for TFBGA24 5x5 ball array package

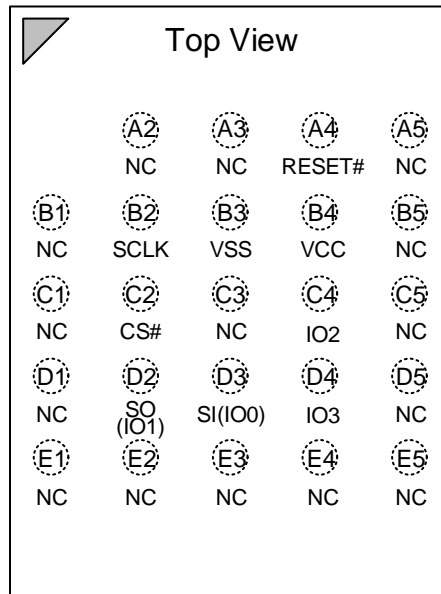

24-BALL TFBGA (5x5 ball array)

Table 3. Pin Description for TFBGA24 Package

Pin No.	Pin Name	I/O	Description
A4	RESET#	I	Reset Input
B2	SCLK	I	Serial Clock Input
B3	VSS		Ground
B4	VCC		Power Supply
C2	CS#	I	Chip Select Input
C4	IO2	I/O	Data Input Output 2
D2	SO (IO1)	I/O	Data Output (Data Input Output 1)
D3	SI (IO0)	I/O	Data Input (Data Input Output 0)
D4	IO3	I/O	Data Input Output 3

Note:

1. CS# must be driven high if chip is not selected. Please don't leave CS# floating any time after power is on.
2. The NC ball is not connected to any internal signal. It is OK to connect it to the system ground (GND) or leave it floating.
3. The RESET# pin is a dedicated hardware reset pin regardless of device settings or operation states. If the hardware reset function is not used, this pin must be connected to VCC in the system.
4. If IO2/IO3 is unused, it must be driven high by the host, or an external pull-up resistor must be placed on the PCB in order to avoid allowing IO2/IO3 input to float.



**BLOCK DIAGRAM**

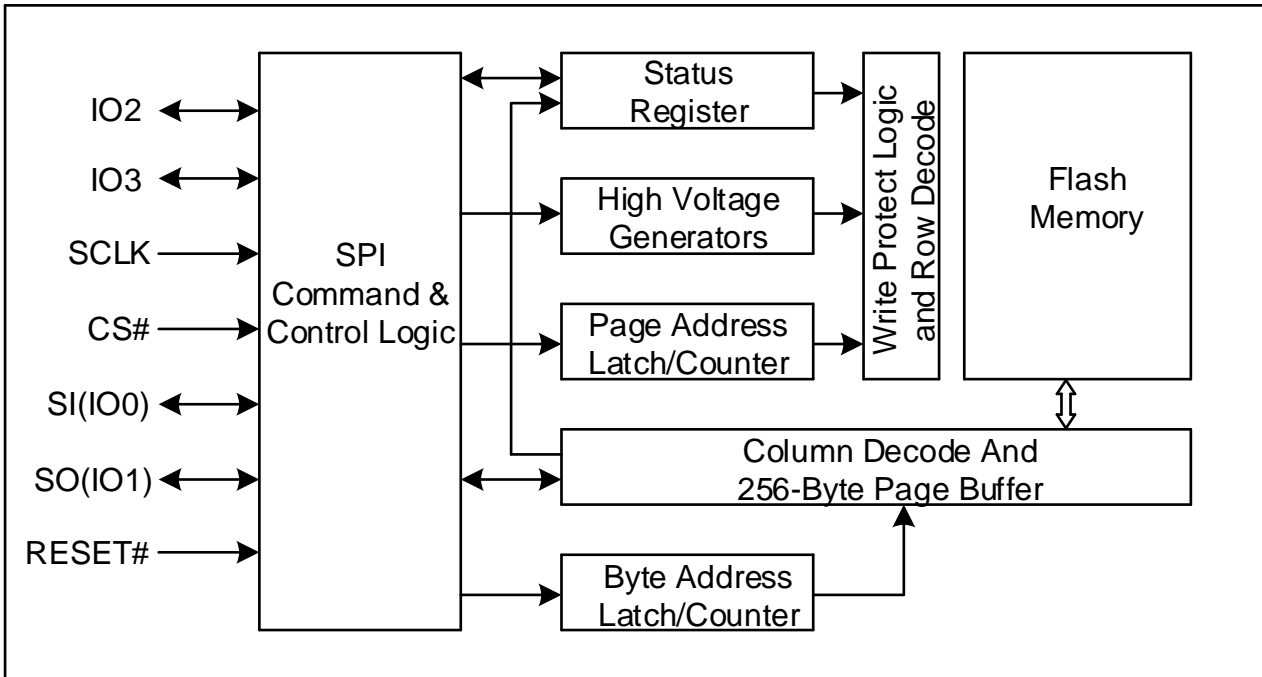





### 3 MEMORY ORGANIZATION

#### GD25LF128E

Each device has	Each block has	Each sector has	Each page has	
16M	64/32K	4K	256	Bytes
64K	256/128	16	-	pages
4K	16/8	-	-	sectors
256/512	-	-	-	blocks

#### UNIFORM BLOCK SECTOR ARCHITECTURE

##### GD25LF128E 64K Bytes Block Sector Architecture

Block	Sector	Address range	
255	4095	FFF000H	FFFFFFH
	.....	.....	.....
	4080	FF0000H	FF0FFFH
254	4079	FEF000H	FEFFFFH
	.....	.....	.....
	4064	FE0000H	FE0FFFH
.....	.....	.....	.....
	.....	.....	.....
	.....	.....	.....
.....	.....	.....	.....
	.....	.....	.....
	.....	.....	.....
2	47	02F000H	02FFFFH
	.....	.....	.....
	32	020000H	020FFFH
1	31	01F000H	01FFFFH
	.....	.....	.....
	16	010000H	010FFFH
0	15	00F000H	00FFFFH
	.....	.....	.....
	0	000000H	000FFFH



## 4 DEVICE OPERATIONS

### 4.1 SPI Mode

#### Standard SPI

The GD25LF128E features a serial peripheral interface on 4 signals bus: Serial Clock (SCLK), Chip Select (CS#), Serial Data Input (SI) and Serial Data Output (SO). Both SPI bus mode 0 and 3 are supported. Input data is latched on the rising edge of SCLK and data shifts out on the falling edge of SCLK.

#### Dual SPI

The GD25LF128E supports Dual SPI operation when using the “Dual Output Fast Read” and “Dual I/O Fast Read” (3BH and BBH) commands. These commands allow data to be transferred to or from the device at twice the rate of the standard SPI. When using the Dual SPI commands, the SI and SO pins become bidirectional I/O pins: IO0 and IO1.

#### Quad SPI

The GD25LF128E supports Quad SPI operation when using the “Quad Output Fast Read”, “Quad I/O Fast Read” (6BH, EBH) commands. These commands allow data to be transferred to or from the device at four times the rate of the standard SPI. When using the Quad SPI commands, the SI and SO pins become bidirectional I/O pins: IO0 and IO1, in addition to IO2 and IO3 pins. For GD25LF128E, the QE bit is set to 1 as default and cannot be changed.

#### DTR Quad SPI

The GD25LF128E supports DTR Quad SPI operation when using the “DTR Quad I/O Fast Read” (EDH) command. This command allows data to be transferred to or from the device at eight times the rate of the standard SPI, and data output will be latched on both rising and falling edges of the serial clock. When using the DTR Quad SPI command, the SI and SO pins become bidirectional I/O pins: IO0 and IO1, in addition to IO2 and IO3 pins. For GD25LF128E, the QE bit is set to 1 as default and cannot be changed.

### 4.2 QPI Mode

The GD25LF128E supports Quad Peripheral Interface (QPI) operations only when the device is switched from Standard/Dual/Quad SPI mode to QPI mode using the “Enable the QPI (38H)” command. The QPI mode utilizes all four IO pins to input the command code. Standard/Dual/Quad SPI mode and QPI mode are exclusive. Only one mode can be active at any given times. “Enable the QPI (38H)” and “Disable the QPI (FFH)” commands are used to switch between these two modes. Upon power-up and after software reset using “Reset (99H)” command, the default state of the device is Standard/Dual/Quad SPI mode. For GD25LF128E, the QE bit is set to 1 as default and cannot be changed.

### 4.3 RESET Function

The RESET# pin goes low for a minimum period of tRLRH (1 $\mu$ s) will reset the flash. After reset cycle, the flash is at the following states:

- Standby mode
- All the volatile bits will return to the default status as power on.



Figure 4 RESET Condition

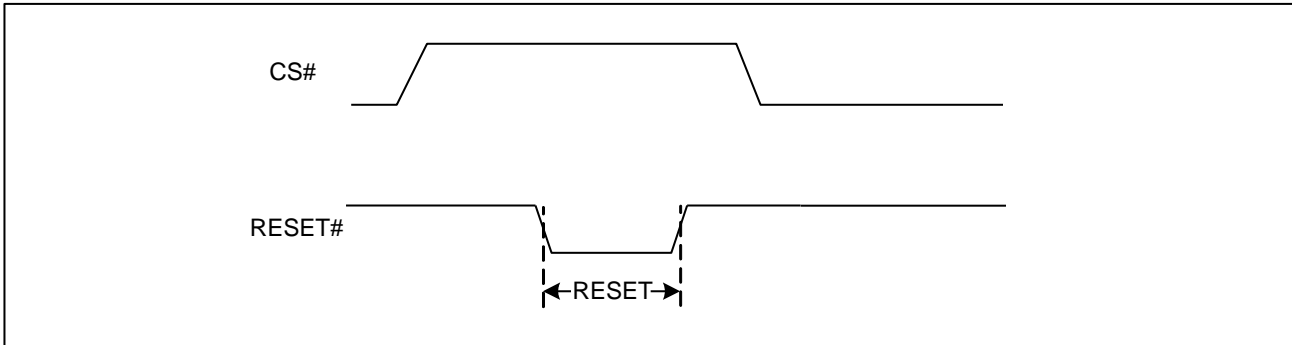



## 5 DATA PROTECTION

The GD25LF128E provide the following data protection methods:

- ◆ Write Enable (WREN) command: The WREN command is set the Write Enable Latch bit (WEL). The WEL bit will return to reset by the following situation:
  - Power-Up / Software Reset (66H+99H)
  - Write Disable (WRDI)
  - Write Status Register (WRSR)
  - Page Program (PP)
  - Sector Erase (SE) / Block Erase (BE) / Chip Erase (CE)
- ◆ Software Protection Mode: The Block Protect bits (BP4-BP0) define the section of the memory array that can be read but not changed.
- ◆ Deep Power-Down Mode: In Deep Power-Down Mode, all commands are ignored except the Release from Deep Power-Down Mode command and Software Reset (66H+99H).
- ◆ Write Inhibit Voltage (VWI): Device would reset automatically when VCC is below a certain threshold VWI.

**Table 4. GD25LF128E Protected area size (CMP=0)**

Status Register Content					Memory Content			
BP4	BP3	BP2	BP1	BP0	Blocks	Addresses	Density	Portion
X	X	0	0	0	NONE	NONE	NONE	NONE
0	0	0	0	1	252 to 255	FC0000H-FFFFFFH	256KB	Upper 1/64
0	0	0	1	0	248 to 255	F80000H-FFFFFFH	512KB	Upper 1/32
0	0	0	1	1	240 to 255	F00000H-FFFFFFH	1MB	Upper 1/16
0	0	1	0	0	224 to 255	E00000H-FFFFFFH	2MB	Upper 1/8
0	0	1	0	1	192 to 255	C00000H-FFFFFFH	4MB	Upper 1/4
0	0	1	1	0	128 to 255	800000H-FFFFFFH	8MB	Upper 1/2
0	1	0	0	1	0 to 3	000000H-03FFFFH	256KB	Lower 1/64
0	1	0	1	0	0 to 7	000000H-07FFFFH	512KB	Lower 1/32
0	1	0	1	1	0 to 15	000000H-0FFFFFFH	1MB	Lower 1/16
0	1	1	0	0	0 to 31	000000H-1FFFFFFH	2MB	Lower 1/8
0	1	1	0	1	0 to 63	000000H-3FFFFFFH	4MB	Lower 1/4
0	1	1	1	0	0 to 127	000000H-7FFFFFFH	8MB	Lower 1/2
X	X	1	1	1	0 to 255	000000H-FFFFFFH	16MB	ALL
1	0	0	0	1	255	FFF000H-FFFFFFH	4KB	Top Block
1	0	0	1	0	255	FFE000H-FFFFFFH	8KB	Top Block
1	0	0	1	1	255	FFC000H-FFFFFFH	16KB	Top Block
1	0	1	0	X	255	FF8000H-FFFFFFH	32KB	Top Block
1	0	1	1	0	255	FF8000H-FFFFFFH	32KB	Top Block
1	1	0	0	1	0	000000H-000FFFH	4KB	Bottom Block
1	1	0	1	0	0	000000H-001FFFH	8KB	Bottom Block
1	1	0	1	1	0	000000H-003FFFH	16KB	Bottom Block
1	1	1	0	X	0	000000H-007FFFH	32KB	Bottom Block



1	1	1	1	0	0	000000H-007FFFFH	32KB	Bottom Block
---	---	---	---	---	---	------------------	------	--------------

**Table 5. GD25LF128E Protected area size (CMP=1)**

Status Register Content					Memory Content			
BP4	BP3	BP2	BP1	BP0	Blocks	Addresses	Density	Portion
X	X	0	0	0	0 to 255	000000H-FFFFFFFH	ALL	ALL
0	0	0	0	1	0 to 251	000000H-FBFFFFFFH	16128KB	Lower 63/64
0	0	0	1	0	0 to 247	000000H-F7FFFFFFH	15872KB	Lower 31/32
0	0	0	1	1	0 to 239	000000H-EFFFFFFFH	15MB	Lower 15/16
0	0	1	0	0	0 to 223	000000H-DFFFFFFFH	14MB	Lower 7/8
0	0	1	0	1	0 to 191	000000H-BFFFFFFFH	12MB	Lower 3/4
0	0	1	1	0	0 to 127	000000H-7FFFFFFFH	8MB	Lower 1/2
0	1	0	0	1	4 to 255	040000H-FFFFFFFH	16128KB	Upper 63/64
0	1	0	1	0	8 to 255	080000H-FFFFFFFH	15872KB	Upper 31/32
0	1	0	1	1	16 to 255	100000H-FFFFFFFH	15MB	Upper 15/16
0	1	1	0	0	32 to 255	200000H-FFFFFFFH	14MB	Upper 7/8
0	1	1	0	1	64 to 255	400000H-FFFFFFFH	12MB	Upper 3/4
0	1	1	1	0	128 to 255	800000H-FFFFFFFH	8MB	Upper 1/2
X	X	1	1	1	NONE	NONE	NONE	NONE
1	0	0	0	1	0 to 255	000000H-FFEFFFFH	16380KB	L-4095/4096
1	0	0	1	0	0 to 255	000000H-FFDFFFFH	16376KB	L-2047/2048
1	0	0	1	1	0 to 255	000000H-FFBFFFFH	16368KB	L-1023/1024
1	0	1	0	X	0 to 255	000000H-FF7FFFFH	16352KB	L-511/512
1	0	1	1	0	0 to 255	000000H-FF7FFFFH	16352KB	L-511/512
1	1	0	0	1	0 to 255	001000H-FFFFFFFH	16380KB	U-4095/4096
1	1	0	1	0	0 to 255	002000H-FFFFFFFH	16376KB	U-2047/2048
1	1	0	1	1	0 to 255	004000H-FFFFFFFH	16368KB	U-1023/1024
1	1	1	0	X	0 to 255	008000H-FFFFFFFH	16352KB	U-511/512
1	1	1	1	0	0 to 255	008000H-FFFFFFFH	16352KB	U-511/512



## 6 STATUS REGISTER

**Table 6. Status Register-SR No.1**

No.	Name	Description	Note
S7	SRP0	Status Register Protection Bit	Non-volatile writable
S6	BP4	Block Protect Bit	Non-volatile writable
S5	BP3	Block Protect Bit	Non-volatile writable
S4	BP2	Block Protect Bit	Non-volatile writable
S3	BP1	Block Protect Bit	Non-volatile writable
S2	BP0	Block Protect Bit	Non-volatile writable
S1	WEL	Write Enable Latch	Volatile, read only
S0	WIP	Erase/Write In Progress	Volatile, read only

**Table 7. Status Register-SR No.2**

No.	Name	Description	Note
S15	SUS1	Erase Suspend Bit	Volatile, read only
S14	CMP	Complement Protect Bit	Non-volatile writable
S13	LB3	Security Register Lock Bit	Non-volatile writable (OTP)
S12	LB2	Security Register Lock Bit	Non-volatile writable (OTP)
S11	LB1	Security Register Lock Bit	Non-volatile writable (OTP)
S10	SUS2	Program Suspend Bit	Volatile, read only
S9	QE	Quad Enable Bit	QE = 1 permanently
S8	SRP1	Status Register Protection Bit	Non-volatile writable

**Table 8. Status Register-SR No.3**

No.	Name	Description	Note
S23	Reserved	Reserved	Reserved
S22	DRV1	Output Driver Strength Bit	Non-volatile writable
S21	DRV0	Output Driver Strength Bit	Non-volatile writable
S20	DLP	Data Learning Pattern Enable bit	Non-volatile writable
S19	Reserved	Reserved	Reserved
S18	Reserved	Reserved	Reserved
S17	DC1	Dummy Configuration Bit	Non-volatile writable
S16	DC0	Dummy Configuration Bit	Non-volatile writable

The status and control bits of the Status Register are as follows:

### WIP bit

The Write in Progress (WIP) bit indicates whether the memory is busy in program/erase/write status register progress. When WIP bit sets to 1, means the device is busy in program/erase/write status register progress, when WIP bit sets 0, means the device is not in program/erase/write status register progress.



**WEL bit**

The Write Enable Latch (WEL) bit indicates the status of the internal Write Enable Latch. When set to 1 the internal Write Enable Latch is set, when set to 0 the internal Write Enable Latch is reset and no Write Status Register, Program or Erase command is accepted.

**BP4, BP3, BP2, BP1, BP0 bits**

The Block Protect (BP4, BP3, BP2, BP1, and BP0) bits are non-volatile. They define the size of the area to be software protected against Program and Erase commands. These bits are written with the Write Status Register (WRSR) command. When the Block Protect (BP4, BP3, BP2, BP1, BP0) bits are set to 1, the relevant memory area (as defined in Table 3&4) becomes protected against Page Program (PP), Sector Erase (SE) and Block Erase (BE) commands. The Chip Erase (CE) command is executed, if the Block Protect (BP2, BP1, and BP0) bits are 0 and CMP=0 or the Block Protect (BP2, BP1, and BP0) bits are 1 and CMP=1.

**SRP1, SRP0 bits**

The Status Register Protect (SRP1 and SRP0) bits are non-volatile Read/Write bits in the status register. The SRP bits control the method of write protection: software protection, power supply lock-down or one time programmable protection.

SRP1	SRP0	Status Register	Description
0	0	Software Protected	The Status Register can be written to after a Write Enable command, WEL=1.(Default)
1	0	Power Supply Lock-Down <sup>(1)(2)</sup>	Status Register is protected and cannot be written to again until the next Power-Down, Power-Up cycle.
1	1	One Time Program <sup>(2)</sup>	Status Register is permanently protected and cannot be written to.

NOTE:

1. When SRP1, SRP0= (1, 0), a Power-Down, Power-Up cycle will change SRP1, SRP0 to (0, 0) state.
2. This feature is available on special order. Please contact GigaDevice for details.

**QE bit**

The Quad Enable (QE) bit is a non-volatile bit in the Status Register that allows Quad operation. The default value of QE bit is 1 and it cannot be changed, so that the IO2 and IO3 pins are enabled all the time.

**LB3, LB2, LB1 bits**

The LB3, LB2 and LB1 bits are non-volatile One Time Program (OTP) bits in Status Register (S13, S12 and S11) that provide the write protect control and status to the Security Registers. The default state of LB3, LB2 and LB1 bits are 0, the security registers are unlocked. The LB3, LB2 and LB1 bits can be set to 1 individually using the Write Register instruction. The LB3, LB2 and LB1 bits are One Time Programmable, once they are set to 1, the Security Registers will become read-only permanently.

**CMP bit**

The CMP bit is a non-volatile Read/Write bit in the Status Register (S14). It is used in conjunction with the BP4-BP0 bits to provide more flexibility for the array protection. Please see the Status registers Memory Protection table for details. The default setting is CMP=0.



**SUS1, SUS2 bits**

The SUS1 and SUS2 bits are read only bits in the status register (S15 and S10) that are set to 1 after executing an Erase/Program Suspend (75H) command (The Erase Suspend will set the SUS1 bit to 1, and the Program Suspend will set the SUS2 bit to 1). The SUS1 and SUS2 bits are cleared to 0 by Erase/Program Resume (7AH) command, software reset (66H+99H) command, as well as a power-down, power-up cycle.

**DC1, DC0 bits**

The Dummy Configuration (DC) bits are non-volatile, which select the number of dummy cycles between the end of address and the start of read data output. Dummy cycles provide additional latency that is needed to complete the initial read access of the flash array before data can be returned to the host system. Some read commands require additional dummy cycles as the SCLK frequency increases.

The following dummy cycle tables provide different dummy cycle settings that are configured.

Command	DC bit	Numbers of Dummy Cycles	Freq.(MHz)
EBH	00 (default)	6	120
	01	6	120
	10	8	133
	11	10	166
EDH	00 (default)	10	104
	01	8	80
	10	10	104
	11	10	104

**DLP bit**

For Quad DTR Read commands, a pre-defined “Data Learning Pattern” can be used by the flash memory controller to determine the flash data output timing on 4 I/O pins. When DLP=1, during the last 4 dummy clocks just prior to the data output, the flash will output “00110100” Data Learning Pattern sequence on each of the 4 I/O pins. During this period, controller can fine tune the data latching timing for each I/O pins to achieve optimum system performance. DLP=0 will disable the Data Learning Pattern output.

**DRV1, DRV0 bits**

The DRV1 and DRV0 bits are used to determine the output driver strength for the Read operations.

**Table 9. Driver Strength for Read Operations**

DRV1, DRV0	Driver Strength
00	100%
01	75% (default)
10	50%
11	25%

**Reserved bit**

It is recommended to set the value of the reserved bit as “0”.





## 7 COMMAND DESCRIPTIONS

All commands, addresses and data are shifted in and out of the device, beginning with the most significant bit on the first rising edge of SCLK after CS# is driven low. Then, the one-byte command code must be shifted in to the device, with most significant bit first on SI, and each bit is latched on the rising edges of SCLK.

Every command sequence starts with a one-byte command code. Depending on the command, this might be followed by address bytes, or by data bytes, or by both or none. CS# must be driven high after the last bit of the command sequence has been completed. For the command of Read, Fast Read, Read Status Register or Release from Deep Power-Down, and Read Device ID, the shifted-in command sequence is followed by a data-out sequence. All read instruction can be completed after any bit of the data-out sequence is being shifted out, and then CS# must be driven high to return to deselected status.

For the command of Page Program, Sector Erase, Block Erase, Chip Erase, Write Status Register, Write Enable, Write Disable or Deep Power-Down command, CS# must be driven high exactly at a byte boundary, otherwise the command is rejected, and is not executed. That is CS# must be driven high when the number of clock pulses after CS# being driven low is an exact multiple of eight. For Page Program, if at any time the input byte is not a full byte, nothing will happen and WEL will not be reset.

**Table 10. Commands (Standard/Dual/Quad SPI)**

Command Name	Byte 1	Byte 2	Byte 3	Byte 4	Byte 5	Byte 6	Byte 7	Byte 8	Byte 9
Write Enable	06H								
Write Disable	04H								
Read Status Register-1	05H	(S7-S0)	(cont.)						
Read Status Register-2	35H	(S15-S8)	(cont.)						
Read Status Register-3	15H	(S23-S16)	(cont.)						
Write Status Register-1&2	01H	S7-S0	S15-S8						
Write Status Register-3	11H	S23-S16							
Volatile SR write Enable	50H								
Read Data	03H	A23-A16	A15-A8	A7-A0	(D7-D0)	(cont.)			
Fast Read	0BH	A23-A16	A15-A8	A7-A0	dummy	(D7-D0)	(cont.)		
Dual Output Fast Read	3BH	A23-A16	A15-A8	A7-A0	dummy	(D7-D0) <sup>(1)</sup>	(cont.)		
Quad Output Fast Read	6BH	A23-A16	A15-A8	A7-A0	dummy	(D7-D0) <sup>(2)</sup>	(cont.)		
Dual I/O Fast Read	BBH	A23-A16 <sup>(3)</sup>	A15-A8 <sup>(3)</sup>	A7-A0 <sup>(3)</sup>	M7-M0 <sup>(4)</sup>	(D7-D0) <sup>(1)</sup>	(cont.)		
Quad I/O Fast Read	EBH	A23-A16 <sup>(5)</sup>	A15-A8 <sup>(5)</sup>	A7-A0 <sup>(5)</sup>	M7-M0 <sup>(6)</sup>	dummy	dummy	(D7-D0) <sup>(2)</sup>	(cont.)
DTR Quad I/O Fast Read	EDH	A23-A16 <sup>(5)</sup>	A15-A8 <sup>(5)</sup>	A7-A0 <sup>(5)</sup>	M7-M0 <sup>(6)</sup>	n-CLK dummy	(D7-D0) <sup>(2)</sup>	(cont.)	



Set Burst with Wrap	77H	dummy <sup>(7)</sup>	dummy <sup>(7)</sup>	dummy <sup>(7)</sup>	W7-W0 <sup>(7)</sup>				
Page Program	02H	A23-A16	A15-A8	A7-A0	D7-D0	Next Byte			
Quad Page Program	32H	A23-A16	A15-A8	A7-A0	D7-D0 <sup>(8)</sup>	Next Byte			
Sector Erase	20H	A23-A16	A15-A8	A7-A0					
Block Erase (32K)	52H	A23-A16	A15-A8	A7-A0					
Block Erase (64K)	D8H	A23-A16	A15-A8	A7-A0					
Chip Erase	C7H/60H								
Read Manufacturer/ Device ID	90H	00H	00H	00H	(MID7- MID0)	(ID7-ID0)	(cont.)		
Read Identification	9FH	(MID7- MID0)	(ID15-ID8)	(ID7-ID0)	(cont.)				
Read Unique ID	4BH	00H	00H	00H	dummy	(UID7- UID0)	(cont.)		
Erase Security Registers <sup>(9)</sup>	44H	A23-A16	A15-A8	A7-A0					
Program Security Registers <sup>(9)</sup>	42H	A23-A16	A15-A8	A7-A0	D7-D0	Next Byte			
Read Security Registers <sup>(9)</sup>	48H	A23-A16	A15-A8	A7-A0	dummy	(D7-D0)	(cont.)		
Enable Reset	66H								
Reset	99H								
Program/Erase Suspend	75H								
Program/Erase Resume	7AH								
Deep Power-Down	B9H								
Release From Deep Power-Down	ABH								
Release From Deep Power-Down and Read Device ID	ABH	dummy	dummy	dummy	(ID7-ID0)	(cont.)			
Enable QPI	38H								
Read Serial Flash Discoverable Parameter	5AH	A23-A16	A15-A8	A7-A0	dummy	(D7-D0)	(cont.)		

**Table 11. Commands (QPI)**

Command Name	Byte 1	Byte 2	Byte 3	Byte 4	Byte 5	Byte 6	Byte 7	Byte 8
Clock Number	(0,1)	(2,3)	(4,5)	(6,7)	(8,9)	(10,11)	(12,13)	(14,15)
Write Enable	06H							
Write Disable	04H							
Read Status Register-1	05H	(S7-S0)						



Read Status Register-2	35H	(S15-S8)						
Read Status Register-3	15H	(S23-S16)						
Write Status Register-1&2	01H	S7-S0	S15-S8					
Write Status Register-3	11H	S23-S16						
Volatile SR Write Enable	50H							
Fast Read	0BH	A23-A16	A15-A8	A7-A0	dummy	dummy	(D7-D0)	(cont.)
Quad I/O Fast Read	EBH	A23-A16	A15-A8	A7-A0	M7-M0	dummy	(D7-D0)	(cont.)
Burst Read with Wrap	0CH	A23-A16	A15-A8	A7-A0	dummy	dummy	(D7-D0)	(cont.)
DTR Quad I/O Fast Read	EDH	A23-A16	A15-A8	A7-A0	M7-M0	n-CLK dummy	(D7-D0)	(cont.)
Set Read Parameters	C0H	P7-P0						
Page Program	02H	A23-A16	A15-A8	A7-A0	D7-D0	Next Byte		
Sector Erase	20H	A23-A16	A15-A8	A7-A0				
Block Erase (32K)	52H	A23-A16	A15-A8	A7-A0				
Block Erase (64K)	D8H	A23-A16	A15-A8	A7-A0				
Chip Erase	C7/60H							
Manufacturer/Device ID	90H	dummy	dummy	00H	(MID7- MID0)	(ID7-ID0)	(cont.)	
Read Identification	9FH	(MID7- MID0)	(ID15-ID8)	(ID7-ID0)	(cont.)			
Enable Reset	66H							
Reset	99H							
Program/Erase Suspend	75H							
Program/Erase Resume	7AH							
Deep Power-Down	B9H							
Release From Deep Power-Down	ABH							
Release From Deep Power-Down, And Read Device ID	ABH	dummy	dummy	dummy	(ID7-ID0)	(cont.)		
Disable QPI	FFH							
Read Serial Flash Discoverable Parameter	5AH	A23-A16	A15-A8	A7-A0	dummy	dummy	(D7-D0)	(cont.)

Note:

1. Dual Output data

IO0 = (D6, D4, D2, D0)

IO1 = (D7, D5, D3, D1)

2. Quad Output Data

IO0 = (D4, D0, ...)

IO1 = (D5, D1, ...)

IO2 = (D6, D2, ...)

IO3 = (D7, D3, ...)



3. Dual Input Address

IO0 = A22, A20, A18, A16, A14, A12, A10, A8      A6, A4, A2, A0

IO1 = A23, A21, A19, A17, A15, A13, A11, A9      A7, A5, A3, A1

4. Dual Input Mode bit

IO0 = M6, M4, M2, M0

IO1 = M7, M5, M3, M1

5. Quad Input Address

IO0 = A20, A16, A12, A8,    A4, A0

IO1 = A21, A17, A13, A9,    A5, A1

IO2 = A22, A18, A14, A10, A6, A2

IO3 = A23, A19, A15, A11, A7, A3

6. Quad Input Mode bit

IO0 = M4, M0

IO1 = M5, M1

IO2 = M6, M2

IO3 = M7, M3

7. Dummy bits and Wrap Bits

IO0 = (x, x, x, x, x, x, W4, x)

IO1 = (x, x, x, x, x, x, W5, x)

IO2 = (x, x, x, x, x, x, W6, x)

IO3 = (x, x, x, x, x, x, x, x)

8. Quad Output Data

IO0 = D4, D0, ...

IO1 = D5, D1, ...

IO2 = D6, D2, ...

IO3 = D7, D3, ...

9. Security Registers Address

Security Register1: A23-A16=00H, A15-A12=1H, A11-A10 = 00b, A9-A0= Byte Address;

Security Register2: A23-A16=00H, A15-A12=2H, A11-A10 = 00b, A9-A0= Byte Address;

Security Register3: A23-A16=00H, A15-A12=3H, A11-A10 = 00b, A9-A0= Byte Address;

10. QPI Command, Address, Data input/output format:

CLK #0 1 2 3 4 5 6 7 8 9 10 11

IO0= C4, C0, A20, A16, A12, A8, A4, A0, D4, D0, D4, D0,

IO1= C5, C1, A21, A17, A13, A9, A5, A1, D5, D1, D5, D1

IO2= C6, C2, A22, A18, A14, A10, A6, A2, D6, D2, D6, D2

IO3= C7, C3, A23, A19, A15, A11, A7, A3, D7, D3, D7, D3

**TABLE OF ID DEFINITIONS**

**GD25LF128E**

Operation Code	MID7-MID0	ID15-ID8	ID7-ID0
9FH	C8	63	18
90H	C8		17
ABH			17



## 7.1 Write Enable (WREN) (06H)

The Write Enable (WREN) command is for setting the Write Enable Latch (WEL) bit. The Write Enable Latch (WEL) bit must be set prior to every Page Program (PP), Quad Page Program (QPP), Sector Erase (SE), Block Erase (BE), Chip Erase (CE), Write Status Register (WRSR) and Erase/Program Security Registers command.

The Write Enable (WREN) command sequence: CS# goes low → sending the Write Enable command → CS# goes high.

**Figure 5. Write Enable Sequence Diagram (SPI)**

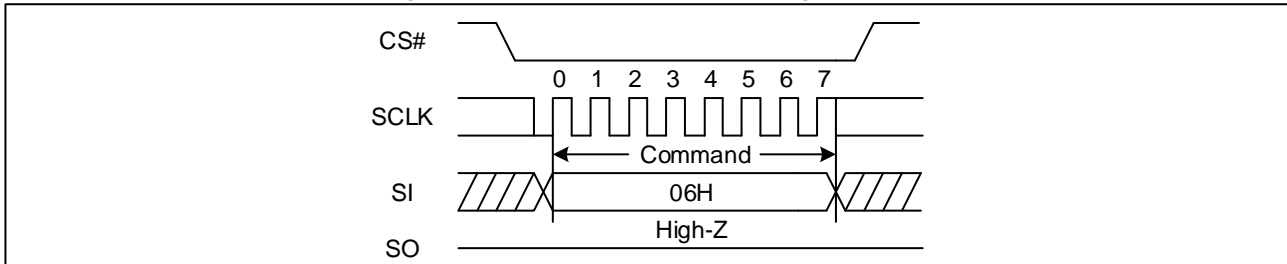

**Figure 6. Write Enable Sequence Diagram (QPI)**

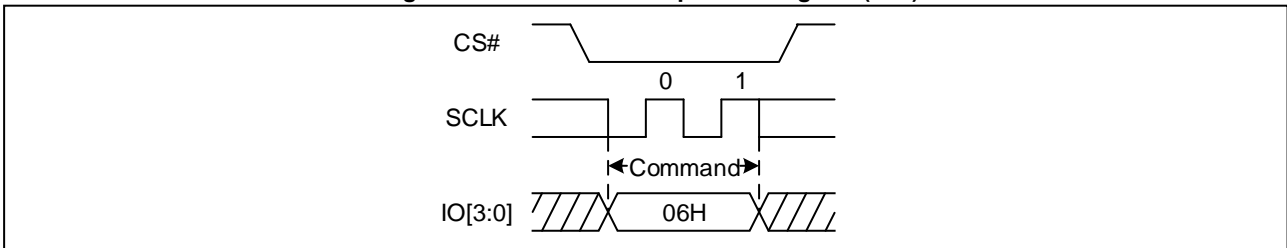

## 7.2 Write Disable (WRDI) (04H)

The Write Disable command is for resetting the Write Enable Latch (WEL) bit. The Write Enable Latch (WEL) bit may be set to 0 by issuing the Write Disable (WRDI) command to disable Page Program (PP), Quad Page Program (QPP), Sector Erase (SE), Block Erase (BE), Chip Erase (CE), Write Status Register (WRSR), that require WEL be set to 1 for execution. The WRDI command can be used by the user to protect memory areas against inadvertent writes that can possibly corrupt the contents of the memory. The WRDI command is ignored during an embedded operation while WIP bit =1.

The WEL bit is reset by following condition: Write Disable command (WRDI), Power-up, and upon completion of the Write Status Register, Page Program, Sector Erase, Block Erase and Chip Erase commands.

The Write Disable command sequence: CS# goes low → Sending the Write Disable command → CS# goes high.

**Figure 7. Write Disable Sequence Diagram (SPI)**

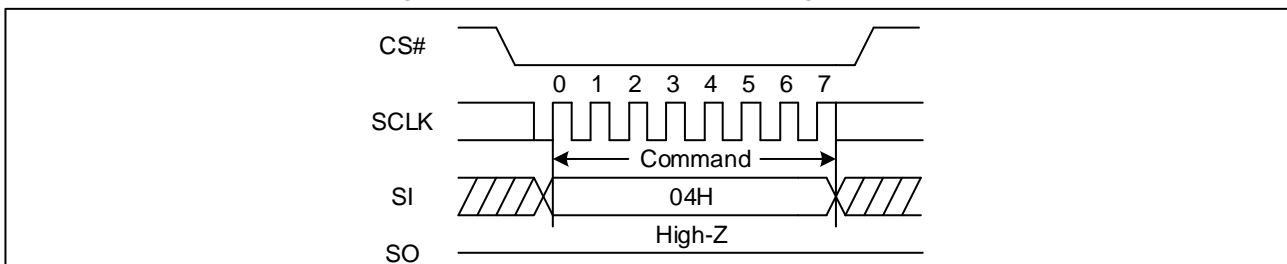



**Figure 8. Write Disable Sequence Diagram (QPI)**

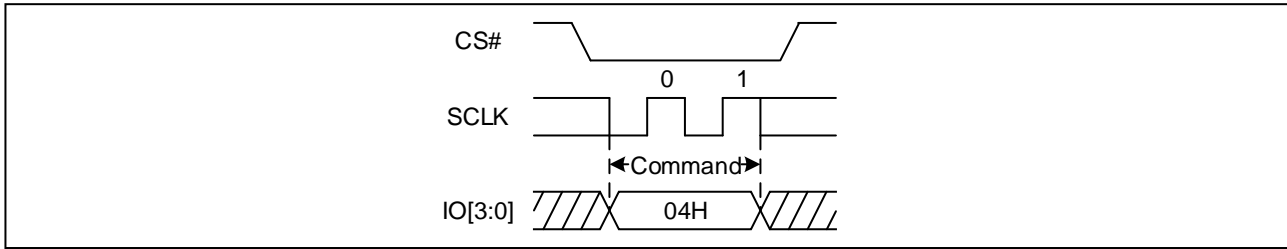

### 7.3 Read Status Register (RDSR) (05H/35H/15H)

The Read Status Register (RDSR) command is for reading the Status Register. The Status Register may be read at any time, even while a Program, Erase or Write Status Register cycle is in progress. When one of these cycles is in progress, it is recommended to check the Write in Progress (WIP) bit before sending a new command to the device. It is also possible to read the Status Register continuously. For command code of “05H” / “35H” / “15H”, the SO will output Status Register bits S7~S0 / S15-S8 / S23-S16.

**Figure 9. Read Status Register Sequence Diagram (SPI)**

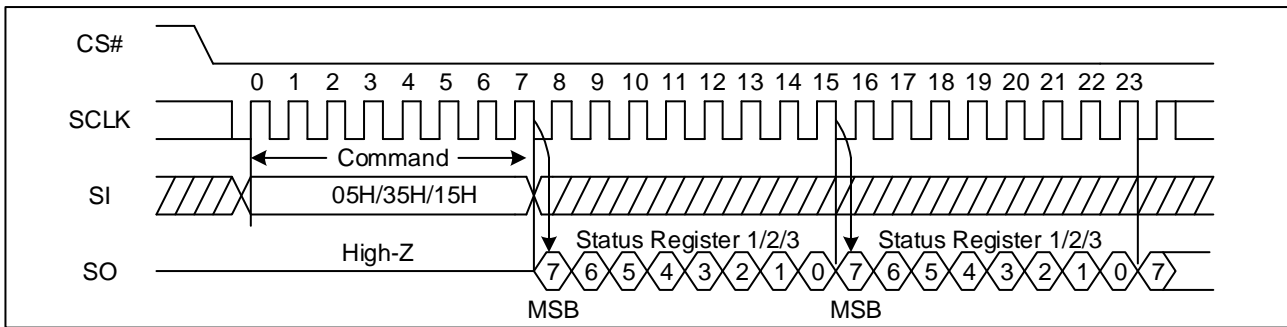

**Figure 10. Read Status Register Sequence Diagram (QPI)**

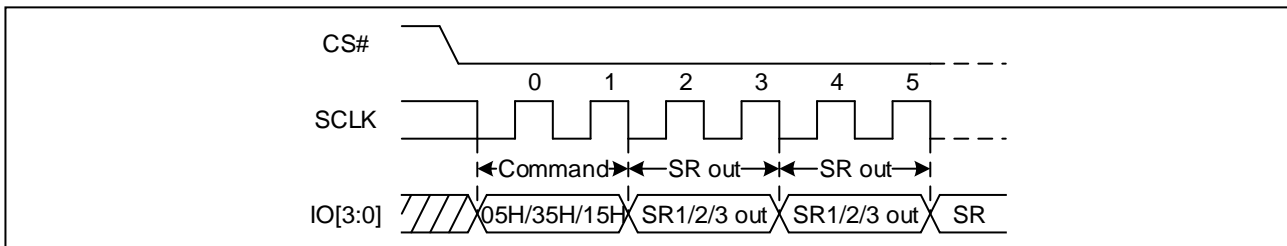

### 7.4 Write Status Register (WRSR) (01H/11H)

The Write Status Register (WRSR) command allows new values to be written to the Status Register. Before it can be accepted, a Write Enable (WREN) command must previously have been executed. After the Write Enable (WREN) command has been decoded and executed, the device sets the Write Enable Latch (WEL).

The Write Status Register (WRSR) command has no effect on S15, S10, S9, S1 and S0 of the Status Register. CS# must be driven high after the eighth or sixteen bit of the data byte has been latched in. Otherwise, the Write Status Register (WRSR) command is not executed. If CS# is driven high after eighth bit of the data byte, the CMP bit will be cleared to 0 in either SPI or QPI mode. As soon as CS# is driven high, the self-timed Write Status Register cycle (whose duration is  $t_w$ ) is initiated. While the Write Status Register cycle is in progress, the Status Register may still be read to check the value of the Write In Progress (WIP) bit. The Write In Progress (WIP) bit is 1 during the self-timed Write Status Register cycle, and is 0 when it is completed. When the cycle is completed, the Write Enable Latch (WEL) is reset.



The Write Status Register (WRSR) command allows the user to change the values of the Block Protect (BP4, BP3, BP2, BP1, and BP0) bits, to define the size of the area that is to be treated as read-only.

01H command is used to write Status Register-1&2. 11H command is used to write Status Register-3.

**Figure 11. Write Status Register-1&2 Sequence Diagram (SPI)**

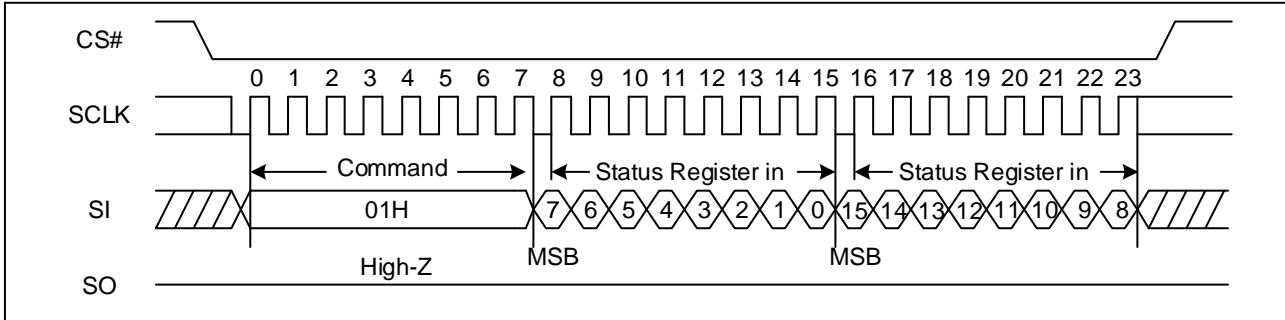

**Figure 12. Write Status Register-1&2 Sequence Diagram (QPI)**

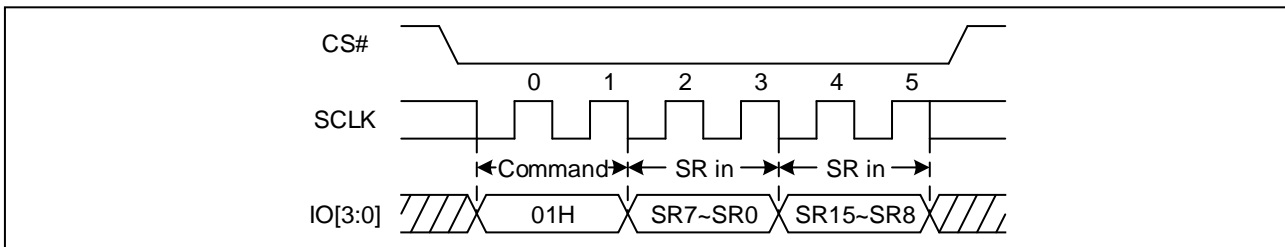

**Figure 13. Write Status Register-3 Sequence Diagram (SPI)**

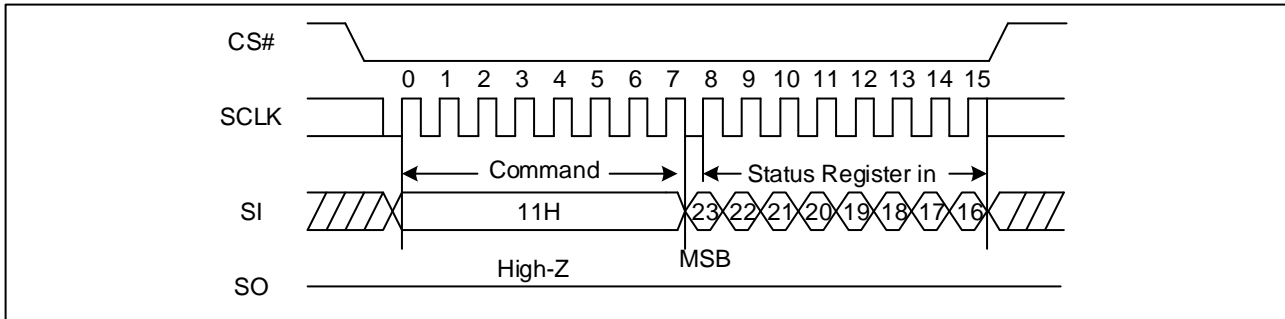

**Figure 14. Write Status Register-3 Sequence Diagram (QPI)**

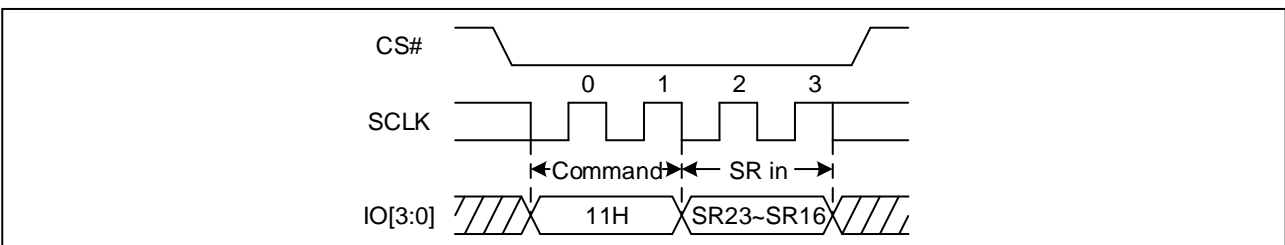

## 7.5 Write Enable for Volatile Status Register (50H)

The non-volatile Status Register bits can also be written to as volatile bits. This gives more flexibility to change the system configuration and memory protection schemes quickly without waiting for the typical non-volatile bit write cycles or affecting the endurance of the Status Register non-volatile bits. The Write Enable for Volatile Status Register command must be



issued prior to a Write Status Register command and any other commands can't be inserted between them. Otherwise, Write Enable for Volatile Status Register will be cleared. The Write Enable for Volatile Status Register command will not set the Write Enable Latch bit, it is only valid for the Write Status Register command to change the volatile Status Register bit values.

**Figure 15. Write Enable for Volatile Status Register Sequence Diagram (SPI)**

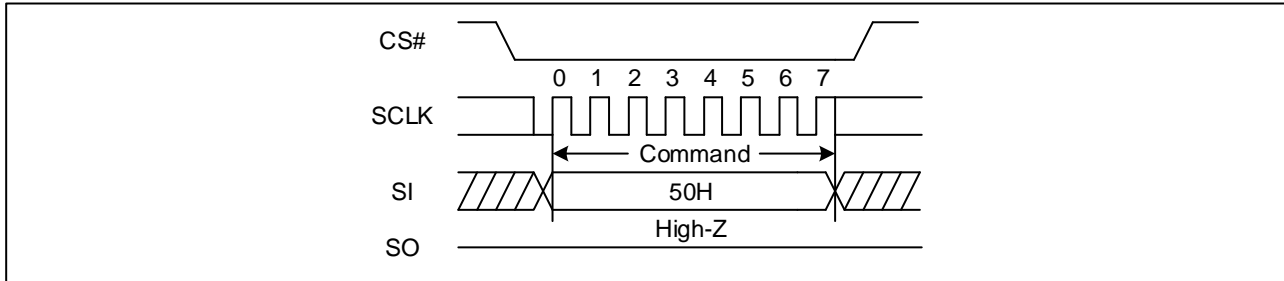

**Figure 16. Write Enable for Volatile Status Register Sequence Diagram (QPI)**

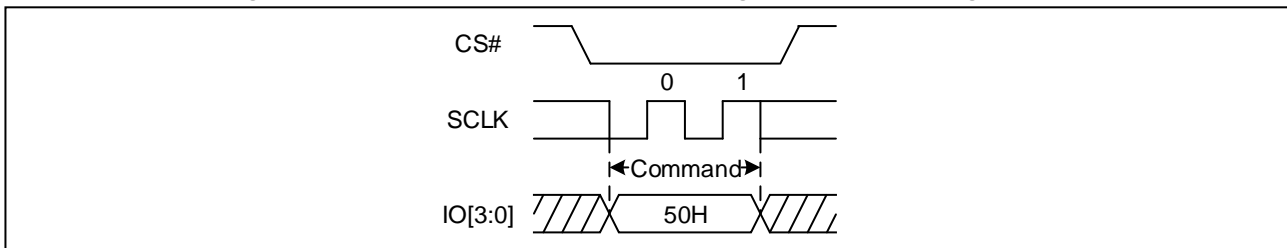

## 7.6 Read Data Bytes (READ) (03H)

The Read Data Bytes (READ) command is followed by a 3-byte address (A23-A0), and each bit is latched-in on the rising edge of SCLK. Then the memory content, at that address, is shifted out on SO, and each bit is shifted out, at a Max frequency  $f_R$ , on the falling edge of SCLK. The first byte addressed can be at any location. The address is automatically incremented to the next higher address after each byte of data is shifted out. The whole memory can, therefore, be read with a single Read Data Bytes (READ) command. Any Read Data Bytes (READ) command, while an Erase, Program or Write cycle is in progress, is rejected without having any effects on the cycle that is in progress.

**Figure 17. Read Data Bytes Sequence Diagram**

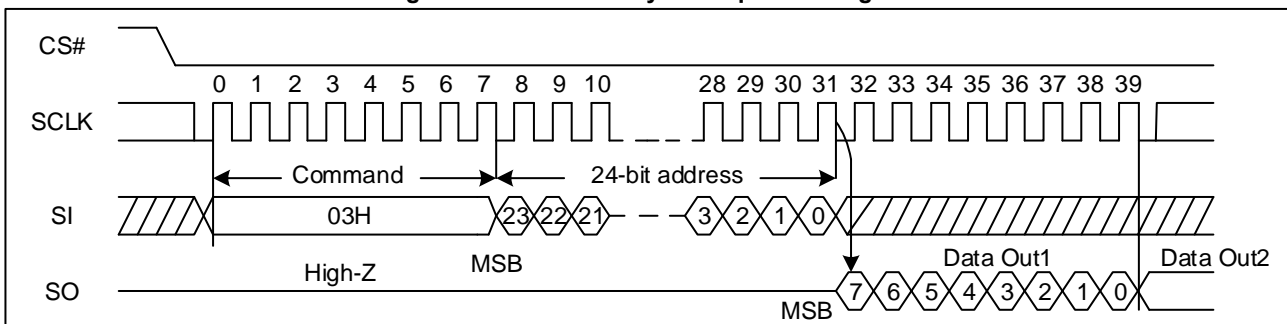

## 7.7 Read Data Bytes at Higher Speed (Fast Read) (0BH)

The Read Data Bytes at Higher Speed (Fast Read) command is for quickly reading data out. It is followed by a 3-byte address (A23-A0) and a dummy byte, and each bit is latched-in on the rising edge of SCLK. Then the memory content, at that address, is shifted out on SO, and each bit is shifted out, at a Max frequency  $f_c$ , on the falling edge of SCLK. The first byte addressed can be at any location. The address is automatically incremented to the next higher address after each byte





of data is shifted out.

The Fast Read command is also supported in QPI mode. In QPI mode, the number of dummy clocks is configured by the "Set Read Parameters (C0H)" command to accommodate a wide range application with different needs for either maximum Fast Read frequency or minimum data access latency. Depending on the Read Parameter Bits P5,P4 setting, the number of dummy clocks can be configured.

**Figure 18. Read Data Bytes at Higher Speed Sequence Diagram (SPI)**

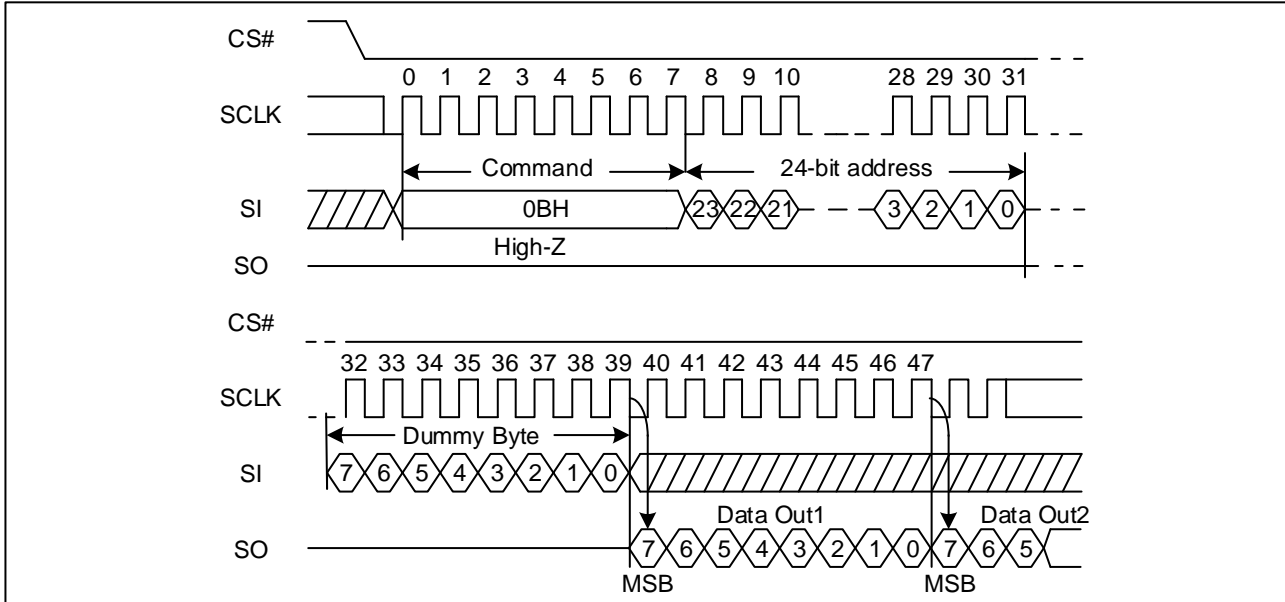

**Figure 19. Read Data Bytes at Higher Speed Sequence Diagram (QPI)**

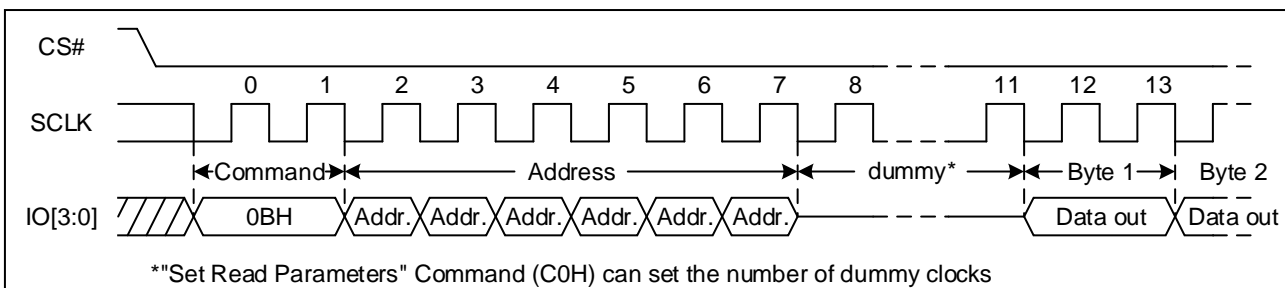

## 7.8 Dual Output Fast Read (3BH)

The Dual Output Fast Read command is followed by 3-byte address (A23-A0) and a dummy byte, and each bit is latched in on the rising edge of SCLK, then the memory contents are shifted out 2-bit per clock cycle from SI and SO.

The first byte addressed can be at any location. The address is automatically incremented to the next higher address after each byte of data is shifted out.

Figure 20. Dual Output Fast Read Sequence Diagram

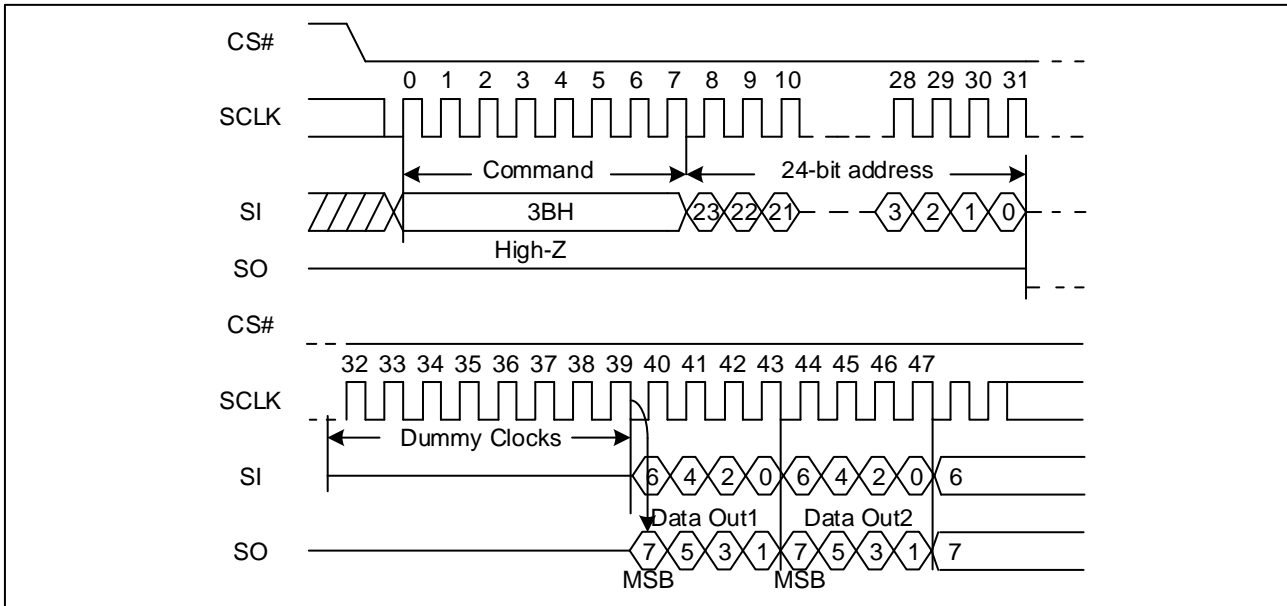

## 7.9 Quad Output Fast Read (6BH)

The Quad Output Fast Read command is followed by 3-byte address (A23-A0) and a dummy byte, and each bit is latched in on the rising edge of SCLK, then the memory contents are shifted out 4-bit per clock cycle from IO3, IO2, IO1 and IO0. The first byte addressed can be at any location. The address is automatically incremented to the next higher address after each byte of data is shifted out.

Figure 21. Quad Output Fast Read Sequence Diagram

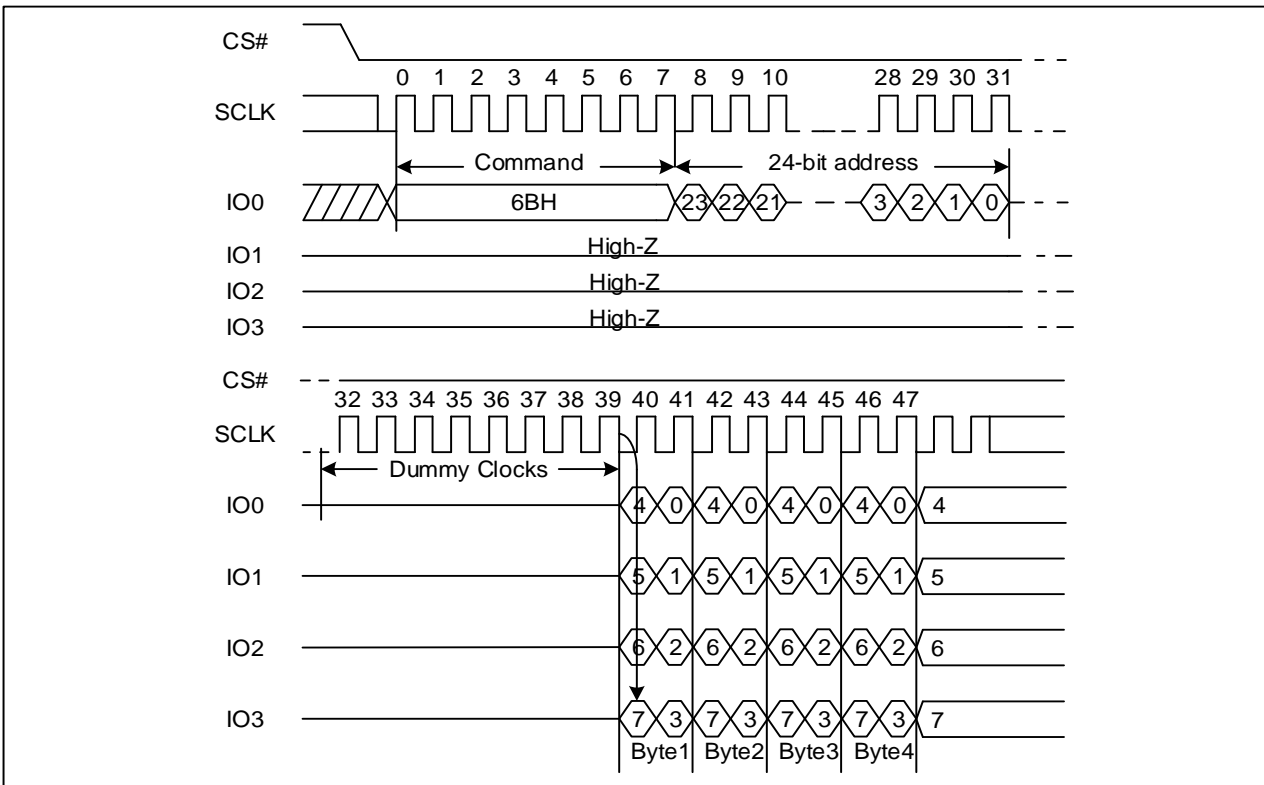



### 7.10 Dual I/O Fast Read (BBH)

The Dual I/O Fast Read command is similar to the Dual Output Fast Read command but with the capability to input the 3-byte address (A23-0) and a “Continuous Read Mode” byte 2-bit per clock by SI and SO, and each bit is latched in on the rising edge of SCLK, then the memory contents are shifted out 2-bit per clock cycle from SI and SO. The first byte addressed can be at any location. The address is automatically incremented to the next higher address after each byte of data is shifted out.

#### Dual I/O Fast Read with “Continuous Read Mode”

The Dual I/O Fast Read command can further reduce command overhead through setting the “Continuous Read Mode” bits (M7-0) after the input 3-byte address (A23-A0). If the “Continuous Read Mode” bits (M5-4) = (1, 0), then the next Dual I/O Fast Read command (after CS# is raised and then lowered) does not require the BBH command code. If the “Continuous Read Mode” bits (M5-4) do not equal (1, 0), the next command requires the command code, thus returning to normal operation. A “Continuous Read Mode” Reset command can be used to reset (M7-0) before issuing normal command.

**Figure 22. Dual I/O Fast Read Sequence Diagram (M5-4 ≠ (1, 0))**

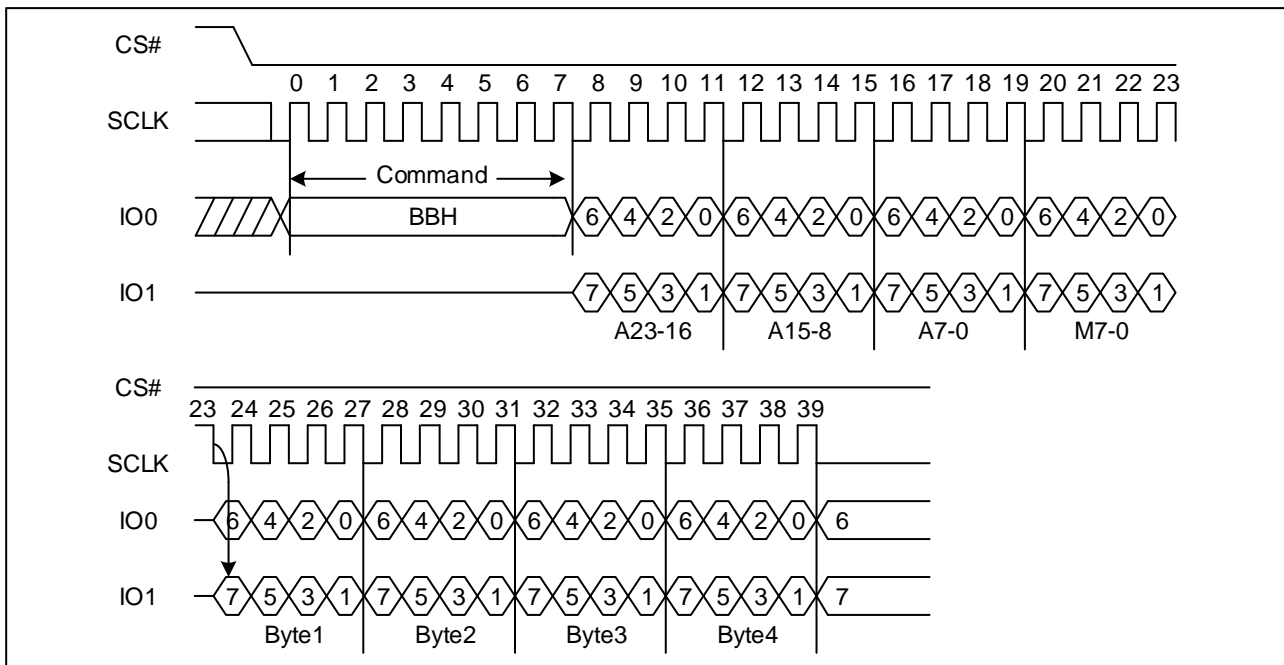



**Figure 23. Dual I/O Fast Read Sequence Diagram (M5-4 = (1, 0))**

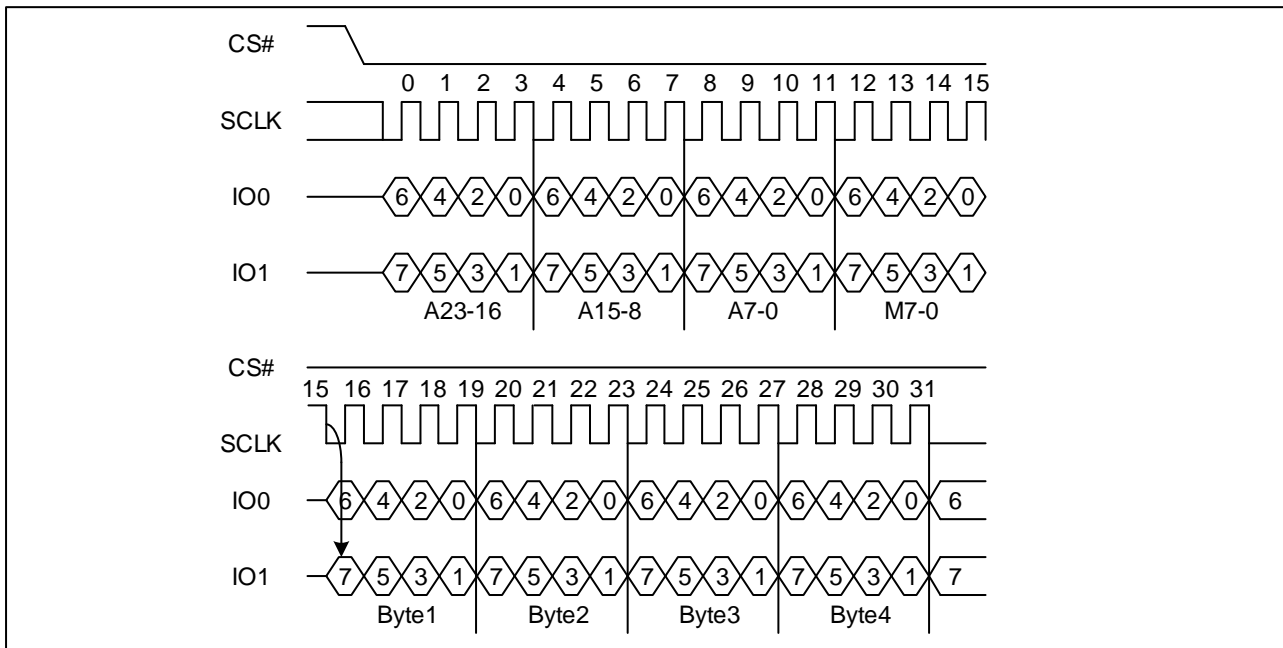

### 7.11 Quad I/O Fast Read (EBH)

The Quad I/O Fast Read command is similar to the Dual I/O Fast Read command but with the capability to input the 3-byte address (A23-0) and a “Continuous Read Mode” byte and 4-dummy clock 4-bit per clock by IO0, IO1, IO2, IO3, and each bit is latched in on the rising edge of SCLK, then the memory contents are shifted out 4-bit per clock cycle from IO0, IO1, IO2, IO3. The first byte addressed can be at any location. The address is automatically incremented to the next higher address after each byte of data is shifted out.

The Quad I/O Fast Read command is also supported in QPI mode. In QPI mode, the number of dummy clocks is configured by the “Set Read Parameters (C0H)” command to accommodate a wide range application with different needs for either maximum Fast Read frequency or minimum data access latency. Depending on the Read Parameter Bits P5~P4 setting, the number of dummy clocks can be configured. To reach the maximum frequency, the device must be set in QPI mode with most dummy clocks. In QPI mode, the “Continuous Read Mode” bits M7-M0 are also considered as dummy clocks. “Continuous Read Mode” feature is also available in QPI mode for Quad I/O Fast Read command. “Wrap Around” feature is not available in QPI mode for Quad I/O Fast Read command. To perform a read operation with fixed data length wrap around in QPI mode, a dedicated “Burst Read with Wrap” (0CH) command must be used.

#### Quad I/O Fast Read with “Continuous Read Mode”

The Quad I/O Fast Read command can further reduce command overhead through setting the “Continuous Read Mode” bits (M7-0) after the input 3-byte address (A23-A0). If the “Continuous Read Mode” bits (M5-4) = (1, 0), then the next Quad I/O Fast Read command (after CS# is raised and then lowered) does not require the EBH command code. If the “Continuous Read Mode” bits (M5-4) do not equal to (1, 0), the next command requires the command code, thus returning to normal operation. A “Continuous Read Mode” Reset command can be used to reset (M7-0) before issuing normal command.



**Figure 24. Quad I/O Fast Read Sequence Diagram (SPI, M5-4 ≠ (1, 0))**

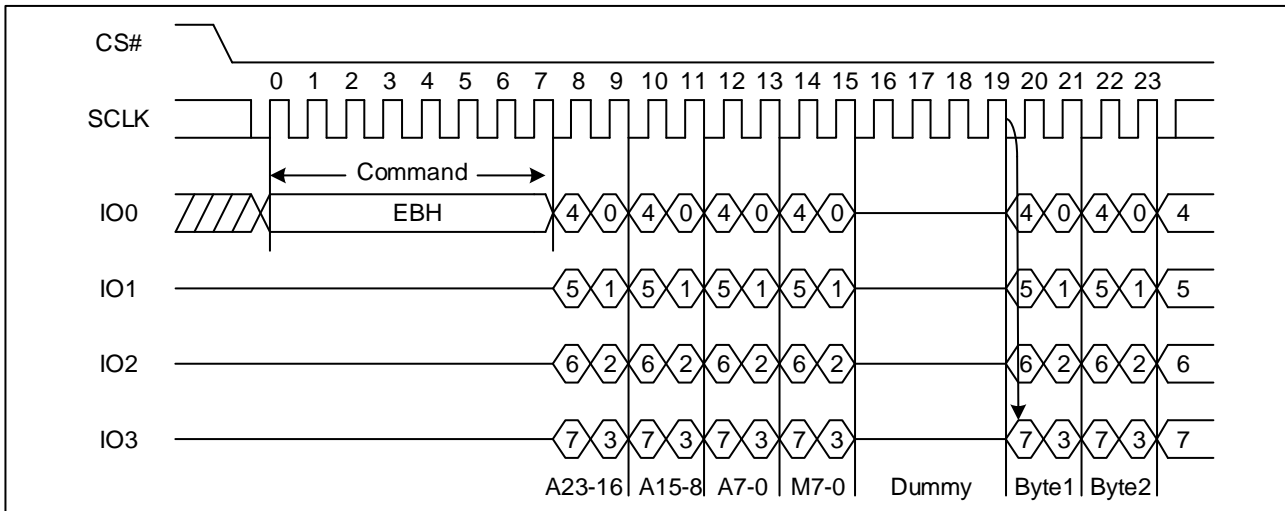

**Figure 25. Quad I/O Fast Read Sequence Diagram (QPI, M5-4 ≠ (1, 0))**

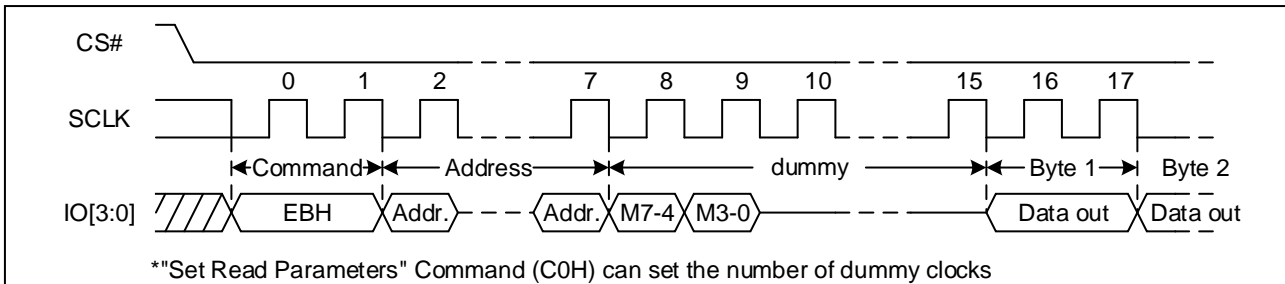

**Figure 26 Quad I/O Fast Read Sequence Diagram (M5-4 = (1, 0))**

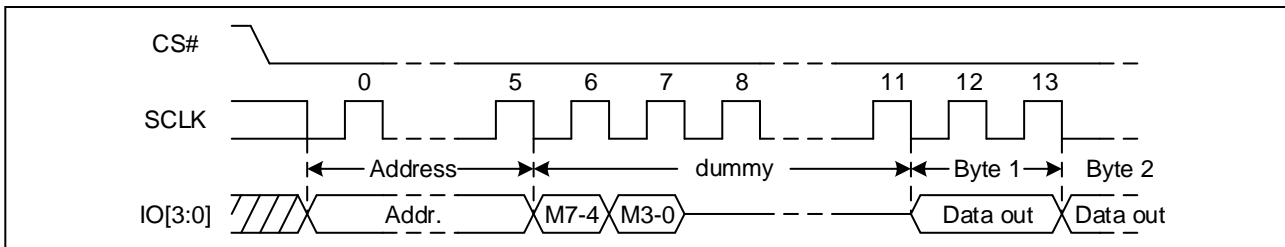

### Quad I/O Fast Read with "8/16/32/64-Byte Wrap Around" in Standard SPI mode

The Quad I/O Fast Read command can be used to access a specific portion within a page by issuing "Set Burst with Wrap" (77H) commands prior to EBH. The "Set Burst with Wrap" (77H) command can either enable or disable the "Wrap Around" feature for the following EBH commands. When "Wrap Around" is enabled, the data being accessed can be limited to either an 8/16/32/64-byte section of a 256-byte page. The output data starts at the initial address specified in the command, once it reaches the ending boundary of the 8/16/32/64-byte section, the output will wrap around the beginning boundary automatically until CS# is pulled high to terminate the command.

The Burst with Wrap feature allows applications that use cache to quickly fetch a critical address and then fill the cache afterwards within a fixed length (8/16/32/64-byte) of data without issuing multiple read commands. The "Set Burst with Wrap" command allows three "Wrap Bits" W6-W4 to be set. The W4 bit is used to enable or disable the "Wrap Around" operation while W6-W5 is used to specify the length of the wrap around section within a page.



### 7.12 Burst Read with Wrap (0CH)

The “Burst Read with Wrap (0CH)” command provides an alternative way to perform the read operation with “Wrap Around” in QPI mode. This command is similar to the “Fast Read (0BH)” command in QPI mode, except the addressing of the read operation will “Wrap Around” to the beginning boundary of the “Wrap Around” once the ending boundary is reached. The “Wrap Length” and the number of dummy clocks can be configured by the “Set Read Parameters (C0H)” command.

**Figure 27. Burst Read with Wrap command Sequence Diagram**

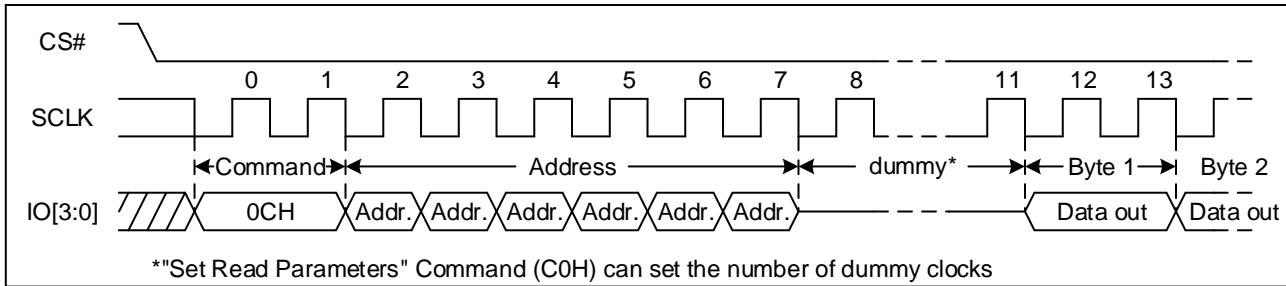

### 7.13 DTR Quad I/O Fast Read (DTRQIO) (EDH)

The DTRQIO instruction enables Double Transfer Rate throughput on quad I/O of Serial Flash in read mode. The address (interleave on 4 I/O pins) is latched on both rising and falling edge of SCLK, and data (interleave on 4 I/O pins) shift out on both rising and falling edge of SCLK. The 8-bit address can be latched-in at one clock, and 8-bit data can be read out at one clock, which means four bits at rising edge of clock, the other four bits at falling edge of clock. The first address byte can be at any location. The address is automatically increased to the next higher address after each byte data is shifted out, so the whole memory can be read out at a single DTRQIO instruction. The address counter rolls over to 0 when the highest address has been reached. Once writing DTRQIO instruction, the following address/dummy/data out will perform as 8-bit instead of previous 1-bit.

While Program/Erase/Write Status Register cycle is in progress, DTRQIO instruction is rejected without any impact on the Program/Erase/Write Status Register current cycle.

#### Quad I/O DTR Read with “Continuous Read Mode”

The Quad I/O DTR Read command can further reduce command overhead through setting the “Continuous Read Mode” bits (M7-0) after the input address. If the “Continuous Read Mode” bits (M5-4) = (1, 0), then the next Quad I/O DTR Read command (after CS# is raised and then lowered) does not require the EDH command code. If the “Continuous Read Mode” bits (M5-4) do not equal to (1, 0), the next command requires the first EDH command code, thus returning to normal operation. The only way to quit the Quad I/O DTR Continuous Read Mode” is to set the “Continuous Read Mode” bits (M5-4) not equal to (1, 0).



**Figure 28. DTR Quad I/O Fast Read Sequence Diagram (SPI, M5-4# (1, 0))**

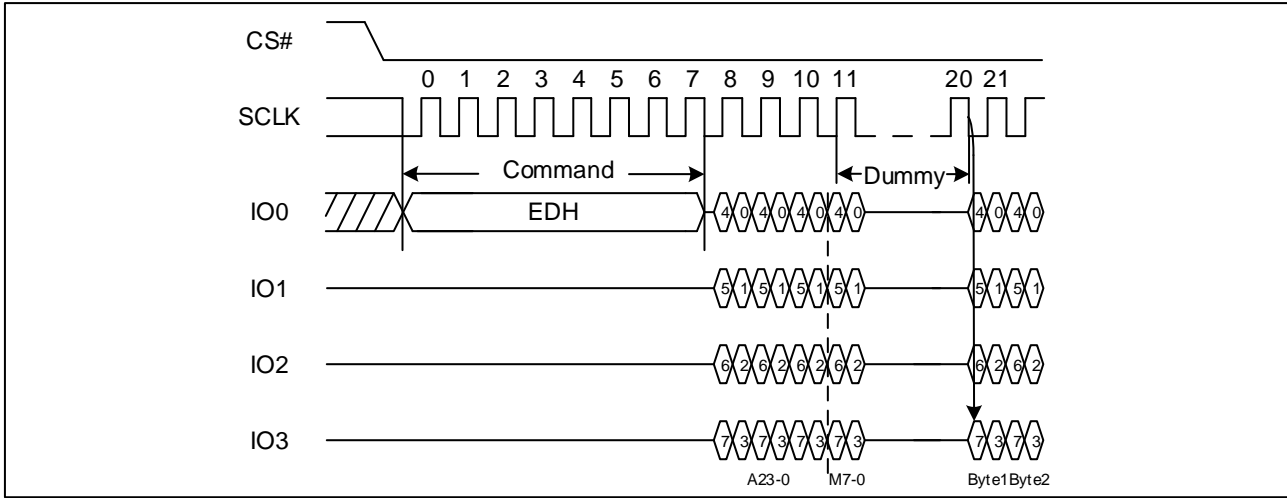

**Figure 29. DTR Quad I/O Fast Read Sequence Diagram (QPI, M5-4# (1, 0))**

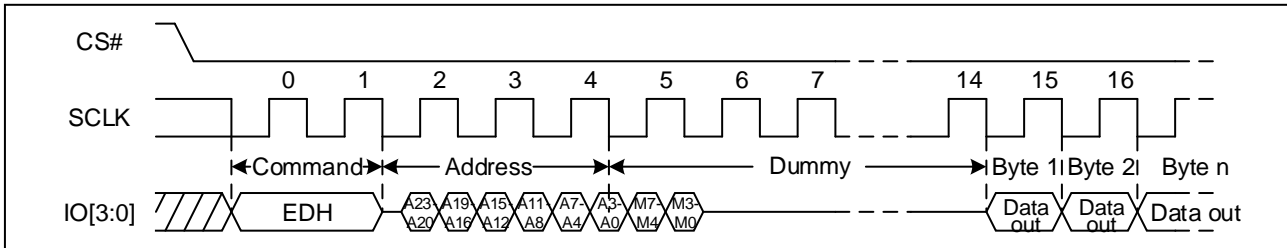

**Figure 30. DTR Quad I/O Fast Read Sequence Diagram (M5-4 = (1, 0))**

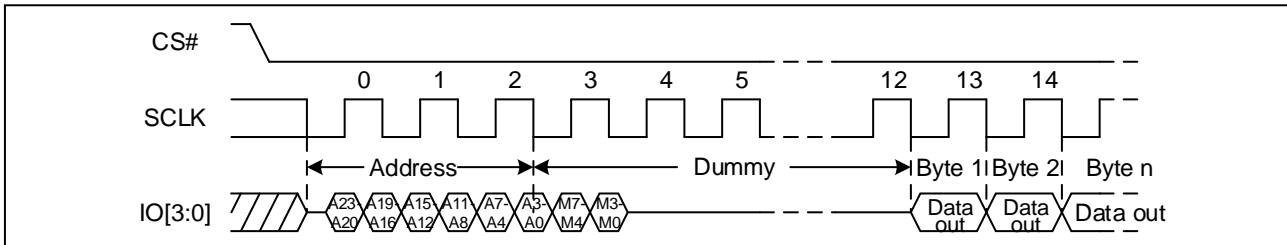

### 7.14 Set Burst with Wrap (77H)

The Set Burst with Wrap command is used in conjunction with “Quad I/O Fast Read” command to access a fixed length of 8/16/32/64-byte section within a 256-byte page, in standard SPI mode.

The Set Burst with Wrap command sequence: CS# goes low → Send Set Burst with Wrap command → Send 24 dummy bits → Send 8 bits “Wrap bits” → CS# goes high.

W6,W5	W4=0		W4=1 (default)	
	Wrap Around	Wrap Length	Wrap Around	Wrap Length
0, 0	Yes	8-byte	No	N/A
0, 1	Yes	16-byte	No	N/A
1, 0	Yes	32-byte	No	N/A
1, 1	Yes	64-byte	No	N/A

If the W6-W4 bits are set by the Set Burst with Wrap command, all the following “Quad I/O Fast Read” command will use



the W6-W4 setting to access the 8/16/32/64-byte section within any page. To exit the “Wrap Around” function and return to normal read operation, another Set Burst with Wrap command should be issued to set W4=1.

**Figure 31. Set Burst with Wrap Sequence Diagram**

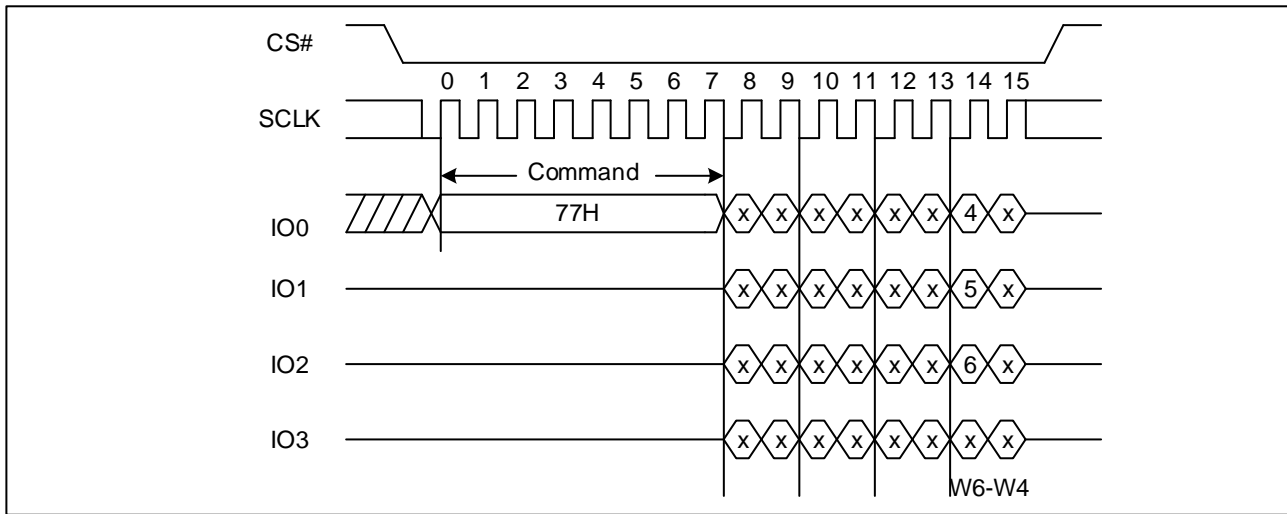

### 7.15 Set Read Parameters (C0H)

In QPI mode the “Set Read Parameters (C0H)” command can be used to configure the number of dummy clocks for “Fast Read (0BH)”, “Quad I/O Fast Read (EBH)”, “DTR Quad I/O Fast Read (EDH)” and “Burst Read with Wrap (0CH)” command, and to configure the number of bytes of “Wrap Length” for the “Burst Read with Wrap (0CH)” command. The “Wrap Length” is set by W5-6 bit in the “Set Burst with Wrap (77H)” command. This wrap setting will remain unchanged when the device is switched from Standard SPI mode to QPI mode.

P5-P4	STR FAST READ		DTR FAST READ		P1-P0	Wrap Length
	Dummy Clocks	Maximum Read Freq.	Dummy Clocks	Maximum Read Freq.		
0 0	4	80MHz	10	104MHz	0 0	8-Byte
0 1	6	108MHz	8	80MHz	0 1	16-Byte
1 0	8	133MHz	10	104MHz	1 0	32-Byte
1 1	10	166MHz	10	104MHz	1 1	64-Byte

**Figure 32. Set Read Parameters command Sequence Diagram**

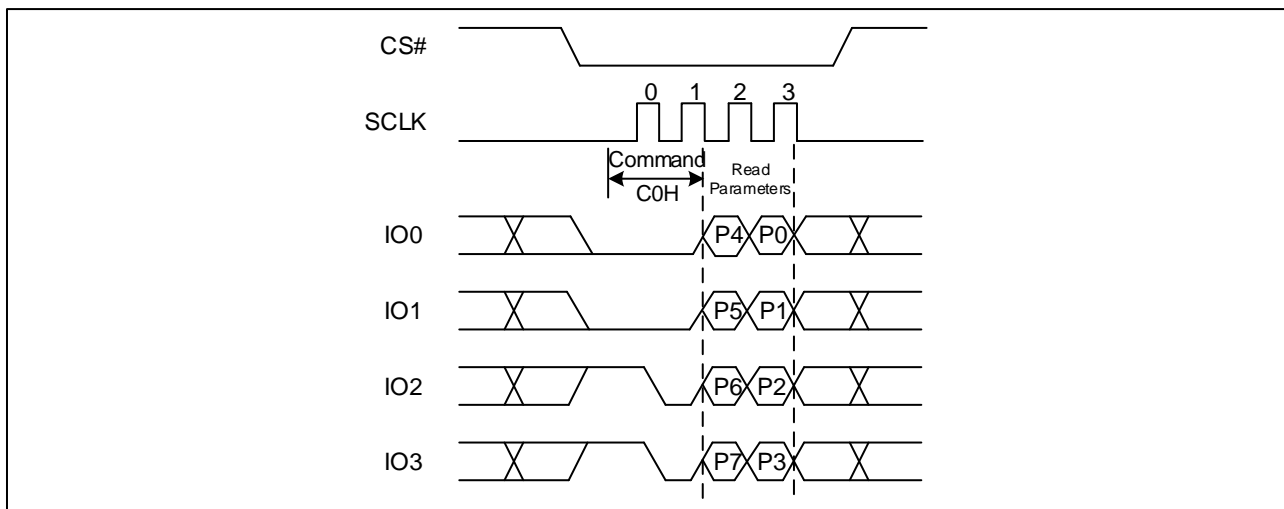





### 7.16 Page Program (PP) (02H)

The Page Program (PP) command is for programming the memory. A Write Enable (WREN) command must previously have been executed to set the Write Enable Latch (WEL) bit before sending the Page Program command.

The Page Program (PP) command is entered by driving CS# Low, followed by the command code, three address bytes and at least one data byte on SI. If the 8 least significant address bits (A7-A0) are not all zero, all transmitted data that goes beyond the end of the current page are programmed from the start address of the same page (from the address whose 8 least significant bits (A7-A0) are all zero). CS# must be driven low for the entire duration of the sequence. The Page Program command sequence: CS# goes low → sending Page Program command → 3-byte address on SI → at least 1 byte data on SI → CS# goes high. If more than 256 bytes are sent to the device, previously latched data are discarded and the last 256 data bytes are guaranteed to be programmed correctly within the same page. If less than 256 data bytes are sent to device, they are correctly programmed at the requested addresses without having any effects on the other bytes of the same page. CS# must be driven high after the eighth bit of the last data byte has been latched in; otherwise the Page Program (PP) command is not executed.

As soon as CS# is driven high, the self-timed Page Program cycle (whose duration is  $t_{PP}$ ) is initiated. While the Page Program cycle is in progress, the Status Register may be read to check the value of the Write in Progress (WIP) bit. The Write in Progress (WIP) bit is 1 during the self-timed Page Program cycle, and is 0 when it is completed. At some unspecified time before the cycle is completed, the Write Enable Latch (WEL) bit is reset.

A Page Program (PP) command applied to a page which is protected by the Block Protect (BP4, BP3, BP2, BP1, and BP0) is not executed.

**Figure 33. Page Program Sequence Diagram (SPI)**

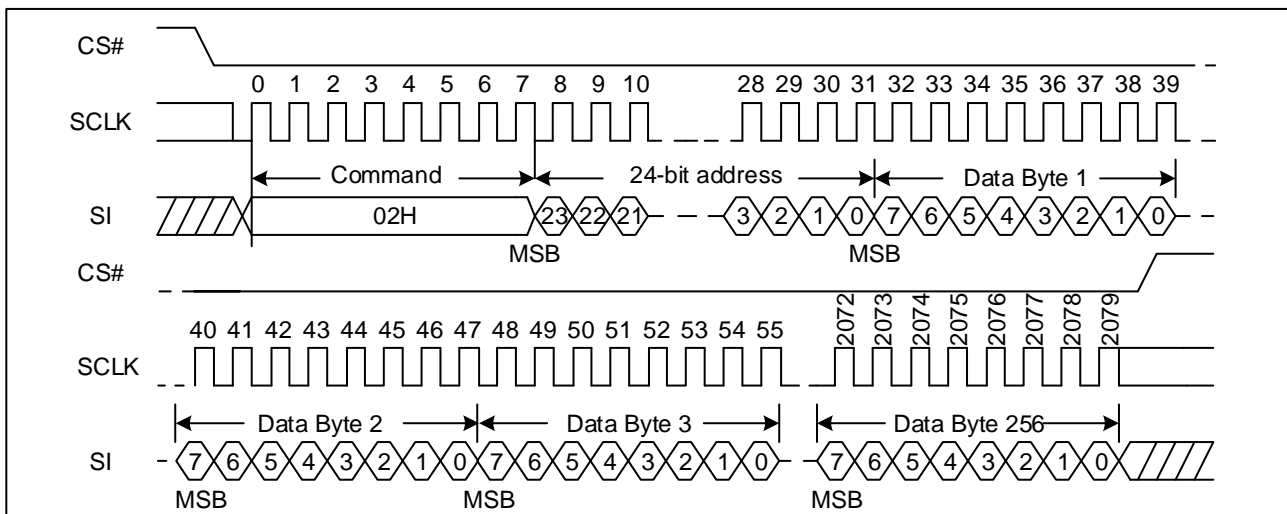

**Figure 34. Page Program Sequence Diagram (QPI)**

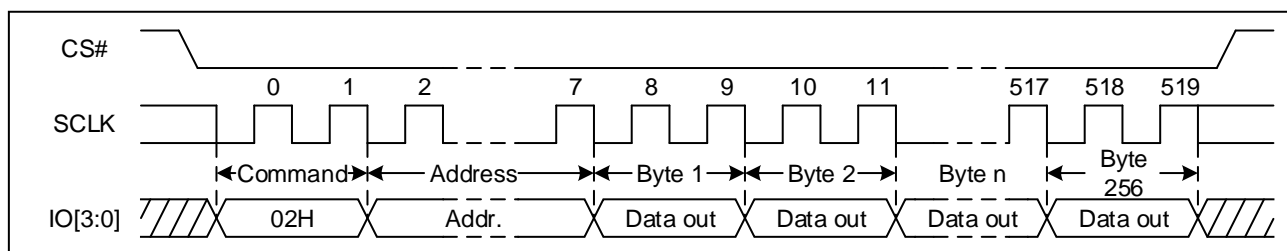

### 7.17 Quad Page Program (32H)

The Quad Page Program command is for programming the memory using four pins: IO0, IO1, IO2, and IO3. A Write Enable



(WREN) command must previously have been executed to set the Write Enable Latch (WEL) bit before sending the Page Program command. The quad Page Program command is entered by driving CS# Low, followed by the command code (32H), three address bytes and at least one data byte on IO pins.

If more than 256 bytes are sent to the device, previously latched data are discarded and the last 256 data bytes are guaranteed to be programmed correctly within the same page. If less than 256 data bytes are sent to device, they are correctly programmed at the requested addresses without having any effects on the other bytes of the same page. CS# must be driven high after the eighth bit of the last data byte has been latched in; otherwise the Quad Page Program (PP) command is not executed.

As soon as CS# is driven high, the self-timed Quad Page Program cycle (whose duration is  $t_{PP}$ ) is initiated. While the Quad Page Program cycle is in progress, the Status Register may be read to check the value of the Write In Progress (WIP) bit. The Write in Progress (WIP) bit is 1 during the self-timed Quad Page Program cycle, and is 0 when it is completed. At some unspecified time before the cycle is completed, the Write Enable Latch (WEL) bit is reset.

A Quad Page Program command applied to a page which is protected by the Block Protect (BP4, BP3, BP2, BP1, and BP0) is not executed.

**Figure 35. Quad Page Program Sequence Diagram**

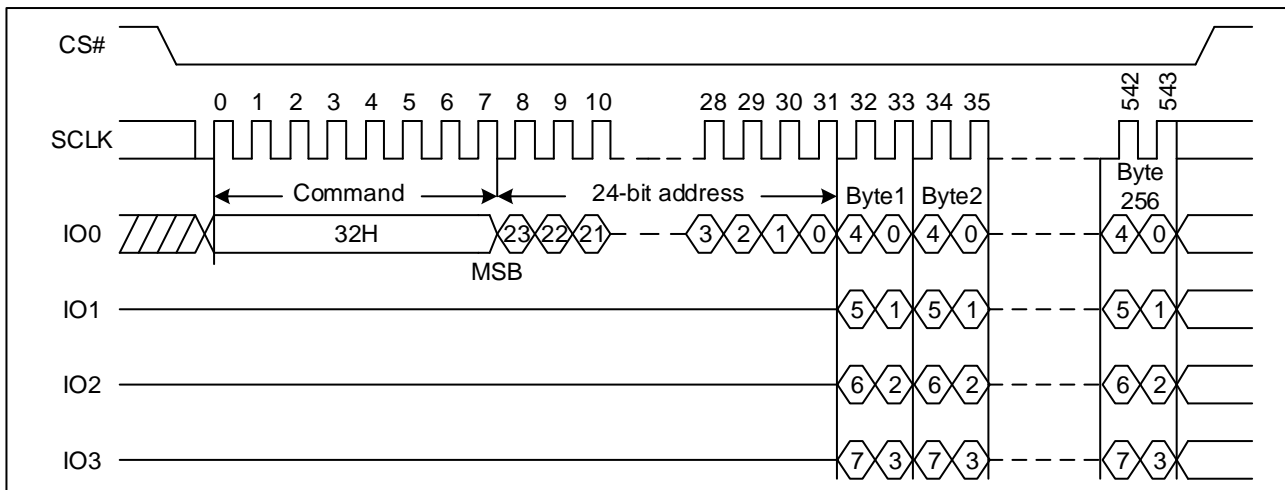

## 7.18 Sector Erase (SE) (20H)

The Sector Erase (SE) command is for erasing the all data of the chosen sector. A Write Enable (WREN) command must previously have been executed to set the Write Enable Latch (WEL) bit. The Sector Erase (SE) command is entered by driving CS# low, followed by the command code, and 3-address byte on SI. Any address inside the sector is a valid address for the Sector Erase (SE) command. CS# must be driven low for the entire duration of the sequence.

The Sector Erase command sequence: CS# goes low → sending Sector Erase command → 3-byte address on SI → CS# goes high. CS# must be driven high after the eighth bit of the last address byte has been latched in; otherwise the Sector Erase (SE) command is not executed. As soon as CS# is driven high, the self-timed Sector Erase cycle (whose duration is  $t_{SE}$ ) is initiated. While the Sector Erase cycle is in progress, the Status Register may be read to check the value of the Write in Progress (WIP) bit. The Write in Progress (WIP) bit is 1 during the self-timed Sector Erase cycle, and is 0 when it is completed. At some unspecified time before the cycle is completed, the Write Enable Latch (WEL) bit is reset. A Sector Erase (SE) command applied to a sector which is protected by the Block Protect (BP4, BP3, BP2, BP1, and BP0) bit is not executed.



**Figure 36. Sector Erase Sequence Diagram (SPI)**

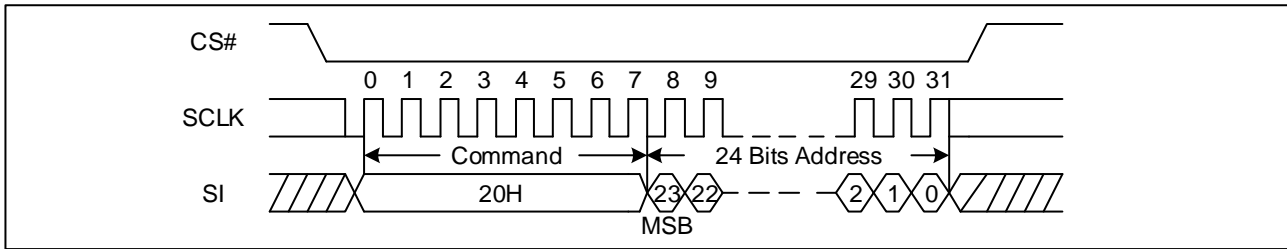

**Figure 37. Sector Erase Sequence Diagram (QPI)**

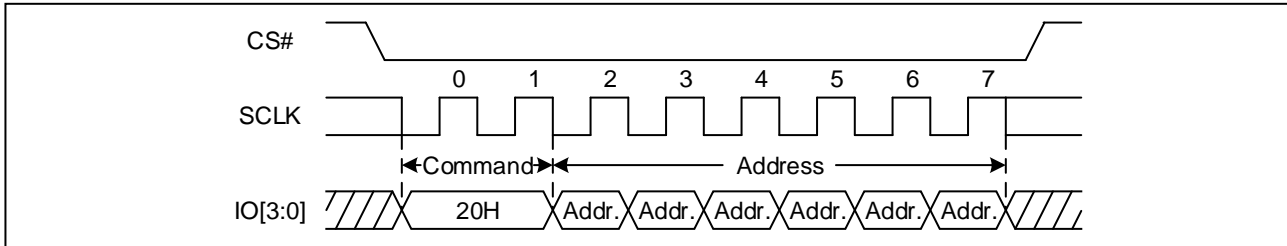

### 7.19 32KB Block Erase (BE32) (52H)

The 32KB Block Erase command is for erasing the all data of the chosen block. A Write Enable (WREN) command must previously have been executed to set the Write Enable Latch (WEL) bit. The 32KB Block Erase command is entered by driving CS# low, followed by the command code, and three address bytes on SI. Any address inside the block is a valid address for the 32KB Block Erase command. CS# must be driven low for the entire duration of the sequence.

The 32KB Block Erase command sequence: CS# goes low → sending 32KB Block Erase command → 3-byte address on SI → CS# goes high. CS# must be driven high after the eighth bit of the last address byte has been latched in; otherwise the 32KB Block Erase command is not executed. As soon as CS# is driven high, the self-timed Block Erase cycle (whose duration is  $t_{BE1}$ ) is initiated. While the Block Erase cycle is in progress, the Status Register may be read to check the value of the Write in Progress (WIP) bit. The Write in Progress (WIP) bit is 1 during the self-timed Block Erase cycle, and is 0 when it is completed. At some unspecified time before the cycle is completed, the Write Enable Latch (WEL) bit is reset. A 32KB Block Erase command applied to a block which is protected by the Block Protect (BP4, BP3, BP2, BP1, and BP0) bits is not executed.

**Figure 38. 32KB Block Erase Sequence Diagram (SPI)**

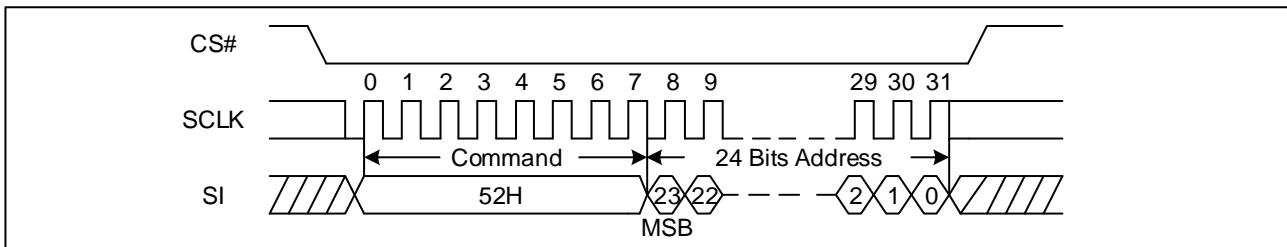

**Figure 39. 32KB Block Erase Sequence Diagram (QPI)**

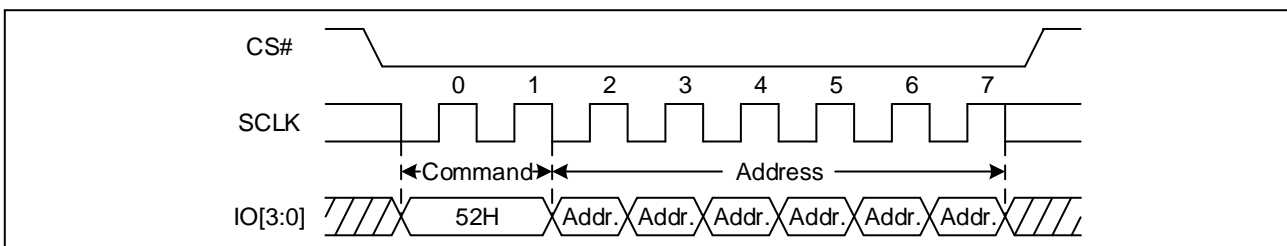



## 7.20 64KB Block Erase (BE64) (D8H)

The 64KB Block Erase command is for erasing the all data of the chosen block. A Write Enable (WREN) command must previously have been executed to set the Write Enable Latch (WEL) bit. The 64KB Block Erase command is entered by driving CS# low, followed by the command code, and three address bytes on SI. Any address inside the block is a valid address for the 64KB Block Erase command. CS# must be driven low for the entire duration of the sequence.

The 64KB Block Erase command sequence: CS# goes low → sending 64KB Block Erase command → 3-byte address on SI → CS# goes high. CS# must be driven high after the eighth bit of the last address byte has been latched in; otherwise the 64KB Block Erase command is not executed. As soon as CS# is driven high, the self-timed Block Erase cycle (whose duration is  $t_{BE2}$ ) is initiated. While the Block Erase cycle is in progress, the Status Register may be read to check the value of the Write in Progress (WIP) bit. The Write in Progress (WIP) bit is 1 during the self-timed Block Erase cycle, and is 0 when it is completed. At some unspecified time before the cycle is completed, the Write Enable Latch (WEL) bit is reset. A 64KB Block Erase command applied to a block which is protected by the Block Protect (BP4, BP3, BP2, BP1, and BP0) bits is not executed.

**Figure 40. 64KB Block Erase Sequence Diagram (SPI)**

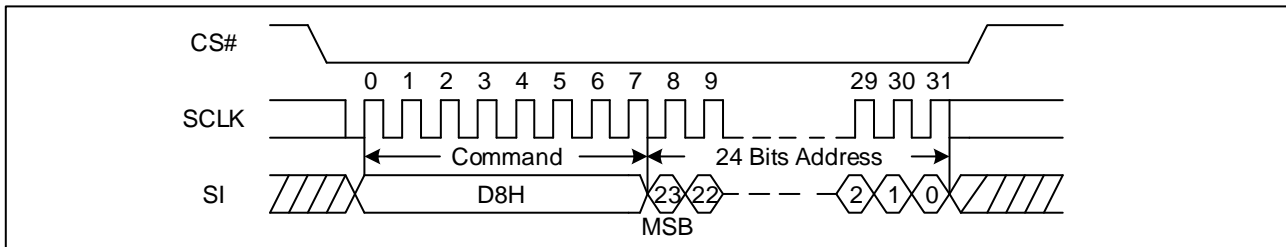

**Figure 41. 64KB Block Erase Sequence Diagram (QPI)**

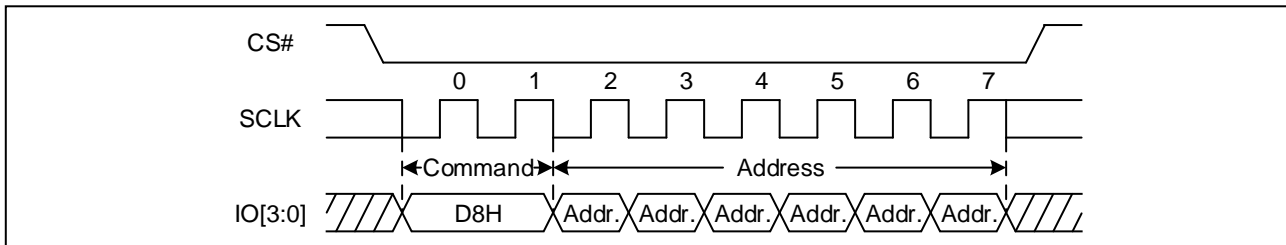

## 7.21 Chip Erase (CE) (60H/C7H)

The Chip Erase (CE) command is for erasing the all data of the chip. A Write Enable (WREN) command must previously have been executed to set the Write Enable Latch (WEL) bit. The Chip Erase (CE) command is entered by driving CS# Low, followed by the command code on Serial Data Input (SI). CS# must be driven Low for the entire duration of the sequence.

The Chip Erase command sequence: CS# goes low → sending Chip Erase command → CS# goes high. CS# must be driven high after the eighth bit of the command code has been latched in; otherwise the Chip Erase command is not executed. As soon as CS# is driven high, the self-timed Chip Erase cycle (whose duration is  $t_{CE}$ ) is initiated. While the Chip Erase cycle is in progress, the Status Register may be read to check the value of the Write in Progress (WIP) bit. The Write in Progress (WIP) bit is 1 during the self-timed Chip Erase cycle, and is 0 when it is completed. At some unspecified time before the cycle is completed, the Write Enable Latch (WEL) bit is reset. The Chip Erase (CE) command is executed, if the Block Protect (BP2, BP1, and BP0) bits are 0 and CMP=0 or the Block Protect (BP2, BP1, and BP0) bits are 1 and CMP=1. The Chip Erase (CE) command is ignored if one or more sectors are protected.



**Figure 42. Chip Erase Sequence Diagram (SPI)**

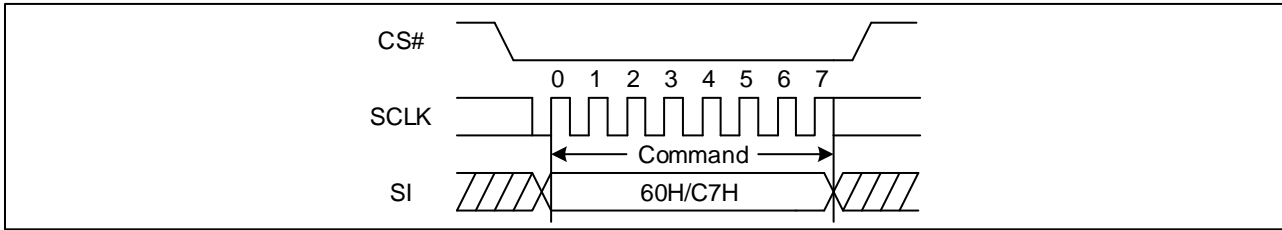

**Figure 43. Chip Erase Sequence Diagram (QPI)**

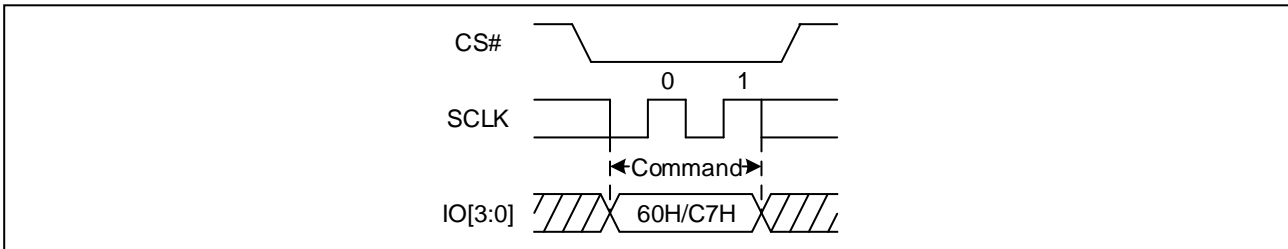

## 7.22 Read Manufacture ID/ Device ID (REMS) (90H)

The Read Manufacturer/Device ID command is an alternative to the Release from Power-Down / Device ID command that provides both the JEDEC assigned Manufacturer ID and the specific Device ID.

The command is initiated by driving the CS# pin low and shifting the command code "90H" followed by a 24-bit address (A23-A0) of 000000H. After which, the Manufacturer ID and the Device ID are shifted out on the falling edge of SCLK with most significant bit (MSB) first.

**Figure 44. Read Manufacture ID/ Device ID Sequence Diagram (SPI)**

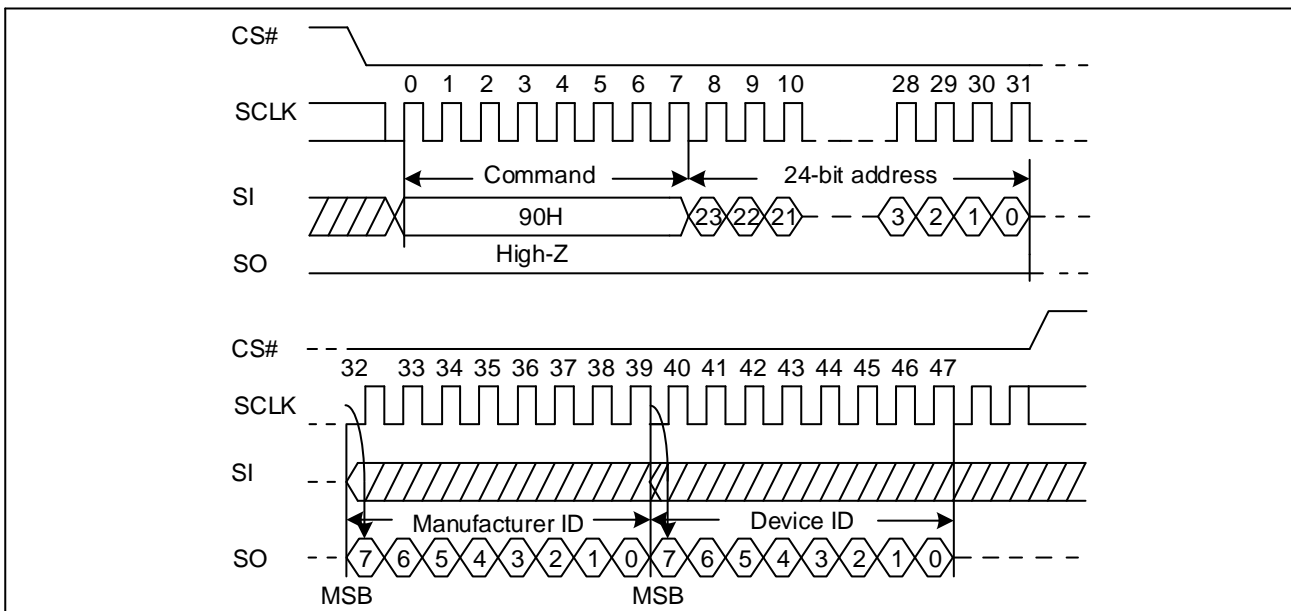



**Figure 45. Read Manufacture ID/ Device ID Sequence Diagram (QPI)**

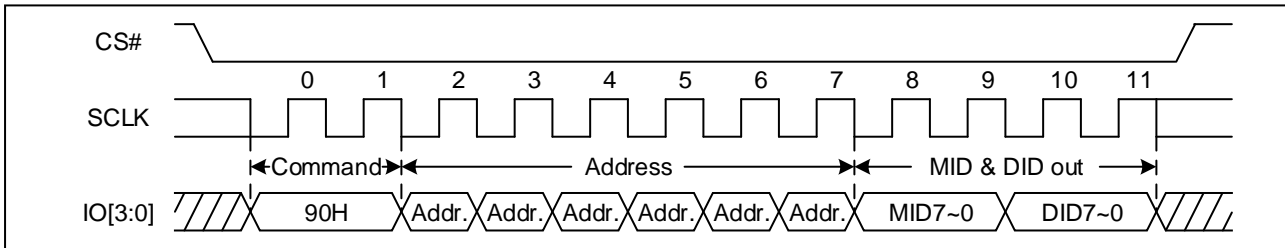

### 7.23 Read Identification (RDID) (9FH)

The Read Identification (RDID) command allows the 8-bit manufacturer identification to be read, followed by two bytes of device identification. The device identification indicates the memory type in the first byte, and the memory capacity of the device in the second byte. The Read Identification (RDID) command while an Erase or Program cycle is in progress, is not decoded, and has no effect on the cycle that is in progress. The Read Identification (RDID) command should not be issued while the device is in Deep Power-Down Mode.

The device is first selected by driving CS# low. Then, the 8-bit command code for the command is shifted in. This is followed by the 24-bit device identification, stored in the memory. Each bit is shifted out on the falling edge of Serial Clock. The Read Identification (RDID) command is terminated by driving CS# high at any time during data output. When CS# is driven high, the device is in the Standby Mode. Once in the Standby Mode, the device waits to be selected, so that it can receive, decode and execute commands.

**Figure 46. Read Identification ID Sequence Diagram (SPI)**

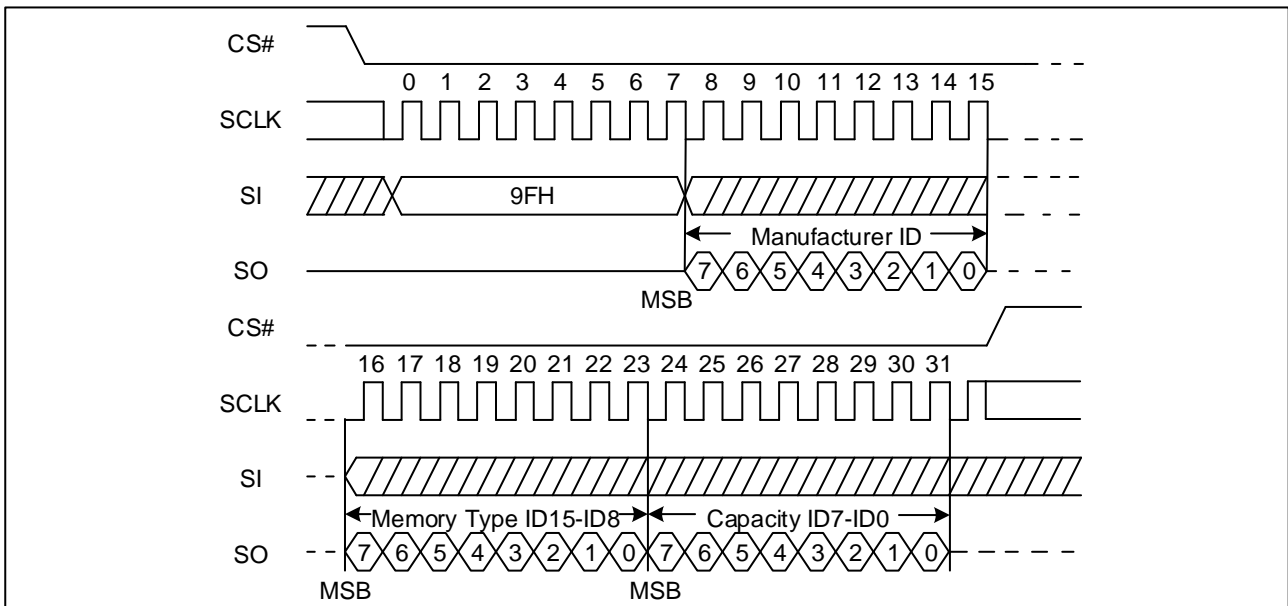

**Figure 47. Read Identification ID Sequence Diagram (QPI)**

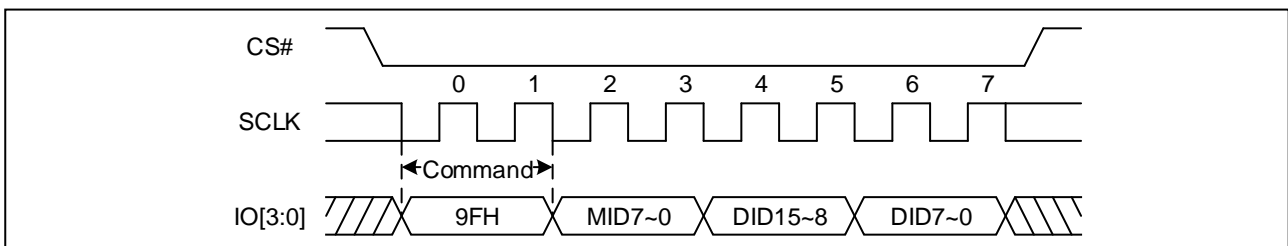



### 7.24 Read Unique ID (4BH)

The Read Unique ID command accesses a factory-set read-only 128bit number that is unique to each device. The Unique ID can be used in conjunction with user software methods to help prevent copying or cloning of a system.

The Read Unique ID command sequence: CS# goes low → sending Read Unique ID command → 3-Byte Address (000000H) → Dummy Byte → 128bit Unique ID Out → CS# goes high.

**Figure 48. Read Unique ID Sequence Diagram**

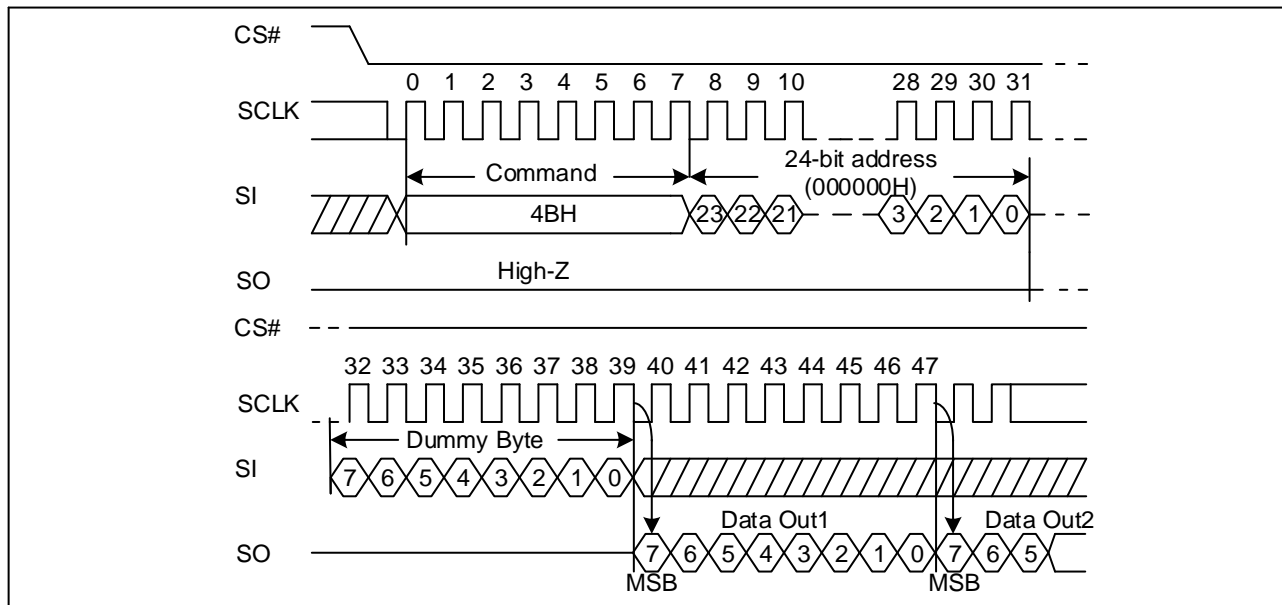

### 7.25 Erase Security Registers (44H)

The GD25LF128E provides 3x1024-Byte Security Registers which can be erased and programmed individually. These registers may be used by the system manufacturers to store security and other important information separately from the main memory array.

The Erase Security Registers command is similar to Sector/Block Erase command. A Write Enable (WREN) command must previously have been executed to set the Write Enable Latch (WEL) bit.

The Erase Security Registers command sequence: CS# goes low → sending Erase Security Registers command → 3-byte address on SI → CS# goes high. The command sequence is shown below. CS# must be driven high after the eighth bit of the last address byte has been latched in; otherwise the Erase Security Registers command is not executed. As soon as CS# is driven high, the self-timed Erase Security Registers cycle (whose duration is  $t_{SE}$ ) is initiated. While the Erase Security Registers cycle is in progress, the Status Register may be read to check the value of the Write in Progress (WIP) bit. The Write in Progress (WIP) bit is 1 during the self-timed Erase Security Registers cycle, and is 0 when it is completed. At some unspecified time before the cycle is completed, the Write Enable Latch (WEL) bit is reset. The Security Registers Lock Bit (LB1, LB2, LB3) in the Status Register can be used to OTP protect the security registers. Once the LB bit is set to 1, the Security Registers will be permanently locked; the Erase Security Registers command will be ignored.

Address	A23-16	A15-12	A11-10	A9-0
Security Register #1	00H	0001b	00b	Don't care
Security Register #2	00H	0010b	00b	Don't care
Security Register #3	00H	0011b	00b	Don't care



**Figure 49. Erase Security Registers command Sequence Diagram**

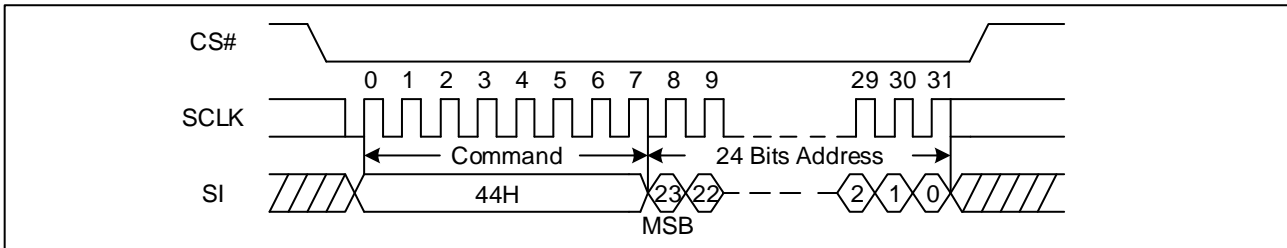

## 7.26 Program Security Registers (42H)

The Program Security Registers command is similar to the Page Program command. Each security register contains four pages content. A Write Enable (WREN) command must previously have been executed to set the Write Enable Latch (WEL) bit before sending the Program Security Registers command. The Program Security Registers command is entered by driving CS# Low, followed by the command code (42H), three address bytes and at least one data byte on SI. As soon as CS# is driven high, the self-timed Program Security Registers cycle (whose duration is  $t_{PP}$ ) is initiated. While the Program Security Registers cycle is in progress, the Status Register may be read to check the value of the Write in Progress (WIP) bit. The Write in Progress (WIP) bit is 1 during the self-timed Program Security Registers cycle, and is 0 when it is completed. At some unspecified time before the cycle is completed, the Write Enable Latch (WEL) bit is reset.

If the Security Registers Lock Bit (LB1, LB2, LB3) is set to 1, the Security Registers will be permanently locked. Program Security Registers command will be ignored.

Address	A23-16	A15-12	A11-10	A9-0
<b>Security Register #1</b>	00H	0001b	00b	Byte Address
<b>Security Register #2</b>	00H	0010b	00b	Byte Address
<b>Security Register #3</b>	00H	0011b	00b	Byte Address

**Figure 50. Program Security Registers command Sequence Diagram**

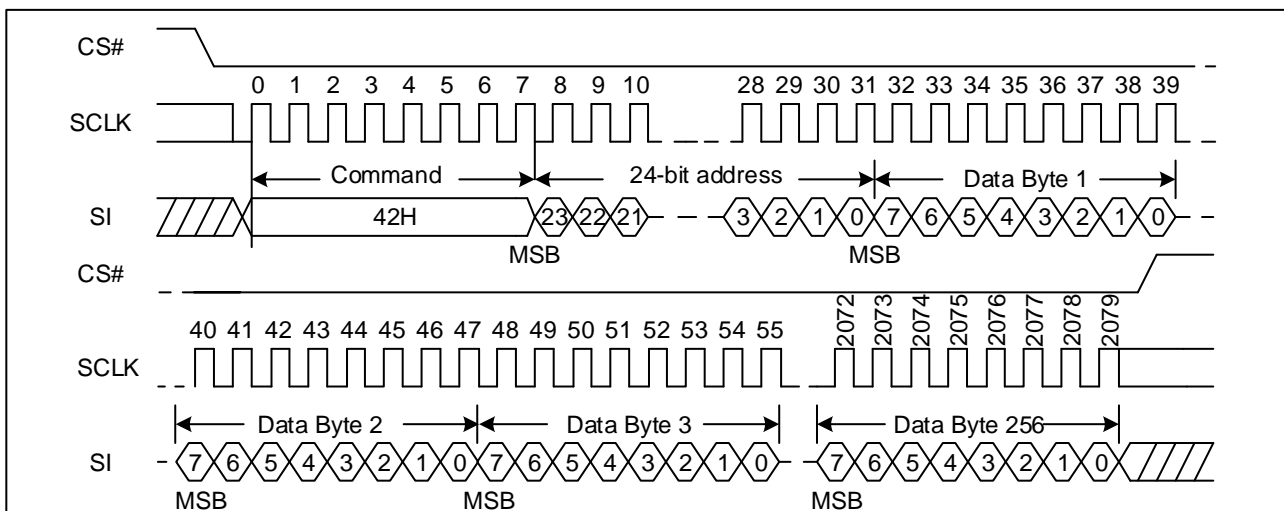

## 7.27 Read Security Registers (48H)

The Read Security Registers command is similar to Fast Read command. The command is followed by a 3-byte address (A23-A0) and a dummy byte, and each bit is latched-in on the rising edge of SCLK. Then the memory content, at that address, is shifted out on SO, and each bit is shifted out, at a Max frequency  $f_c$ , on the falling edge of SCLK. The first byte





addressed can be at any location. The address is automatically incremented to the next higher address after each byte of data is shifted out. Once the A9-0 address reaches the last byte of the register (Byte 3FFH), it will reset to 000H, the command is completed by driving CS# high.

Address	A23-16	A15-12	A11-10	A9-0
Security Register #1	00H	0001b	00b	Byte Address
Security Register #2	00H	0010b	00b	Byte Address
Security Register #3	00H	0011b	00b	Byte Address

**Figure 51. Read Security Registers command Sequence Diagram**

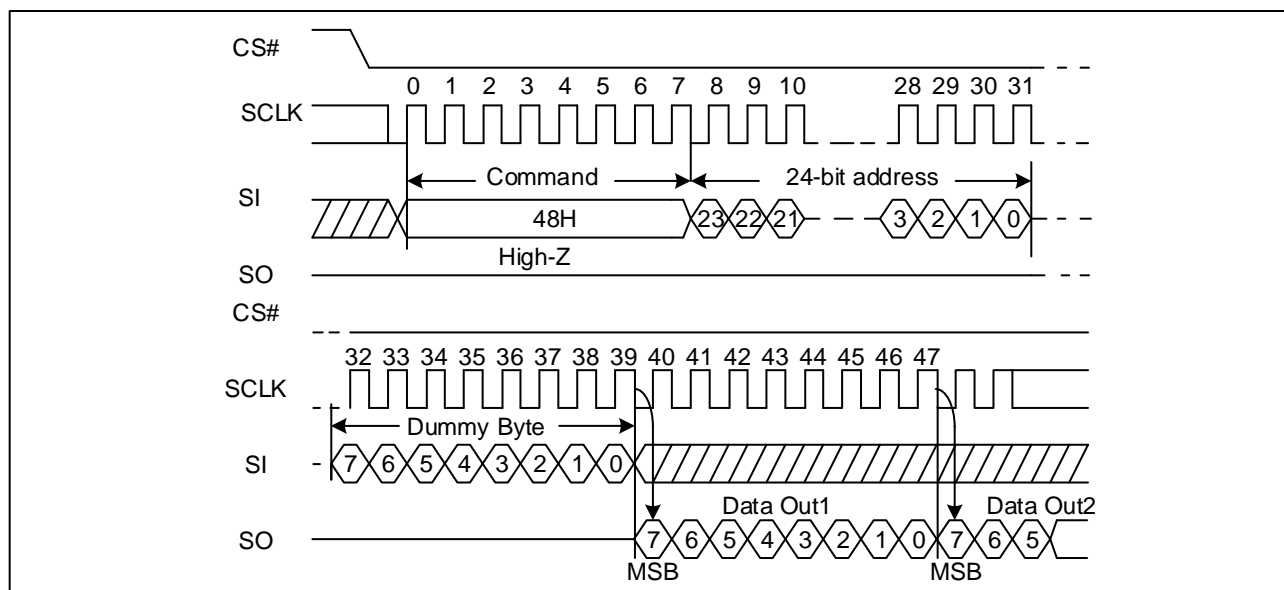

## 7.28 Enable Reset (66H) and Reset (99H)

If the Reset command is accepted, any on-going internal operation will be terminated and the device will return to its default power-on state and lose all the current volatile settings, such as Volatile Status Register bits, Write Enable Latch status (WEL), Program/Erase Suspend status, Read Parameter setting (P7-P0), Deep Power Down Mode, Continuous Read Mode bit setting (M7-M0) and Wrap Bit Setting (W6-W4).

The “Enable Reset (66H)” and the “Reset (99H)” commands can be issued in either SPI or QPI mode. The “Enable Reset (66H)” and “Reset (99H)” command sequence as follow: CS# goes low → Sending Enable Reset command → CS# goes high → CS# goes low → Sending Reset command → CS# goes high. Once the Reset command is accepted by the device, the device will take approximately  $t_{RST}/t_{RST\_E}$  to reset. During this period, no command will be accepted. Data corruption may happen if there is an on-going or suspended internal Erase or Program operation when Reset command sequence is accepted by the device. It is recommended to check the WIP bit and the SUS1/SUS2 bit in Status Register before issuing the Reset command sequence.



**Figure 52. Enable Reset and Reset command Sequence Diagram (SPI)**

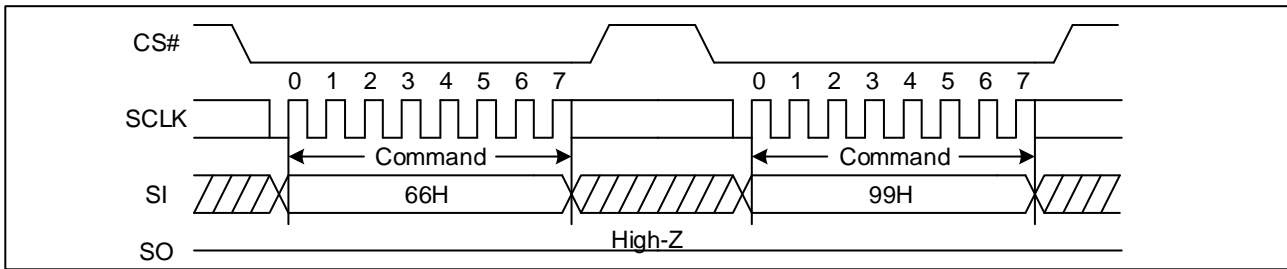

**Figure 53. Enable Reset and Reset command Sequence Diagram (QPI)**

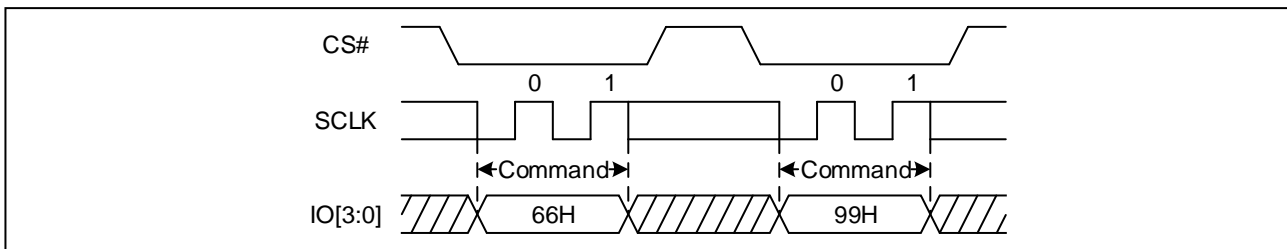

Note: Enable Reset (66H) and Reset (99H) commands cannot reset the device when the device is in Quad I/O DTR Continuous Read Mode. The only way to quit the Quad I/O DTR Continuous Read Mode is to set the “Continuous Read Mode” bits (M5-4) not equal to (1,0).

## 7.29 Program/Erase Suspend (PES) (75H)

The Program/Erase Suspend command “75H”, allows the system to interrupt a page program or sector/block erase operation and then read data from any other sector or block. The Write Status Register command (01H, 11H) and Erase/Program Security Registers command (44H, 42H) and Erase commands (20H, 52H, D8H, C7H, 60H) and Page Program command (02H, 32H) are not allowed during Program suspend. The Write Status Register command (01H, 11H) and Erase Security Registers command (44H) and Erase commands (20H, 52H, D8H, C7H, 60H) are not allowed during Erase suspend. Program/Erase Suspend is valid only during the page program or sector/block erase operation. A maximum of time of “tsus” (See AC Characteristics) is required to suspend the program/erase operation.

The Program/Erase Suspend command will be accepted by the device only if the SUS1/SUS2 bit in the Status Register equal to 0 and WIP bit equal to 1 while a Page Program or a Sector or Block Erase operation is on-going. If the SUS1/SUS2 bit equal to 1 or WIP bit equal to 0, the Suspend command will be ignored by the device. The WIP bit will be cleared from 1 to 0 within “tsus” and the SUS1/SUS2 bit will be set from 0 to 1 immediately after Program/Erase Suspend. A power-off during the suspend period will reset the device and release the suspend state.

**Figure 54. Program/Erase Suspend Sequence Diagram (SPI)**

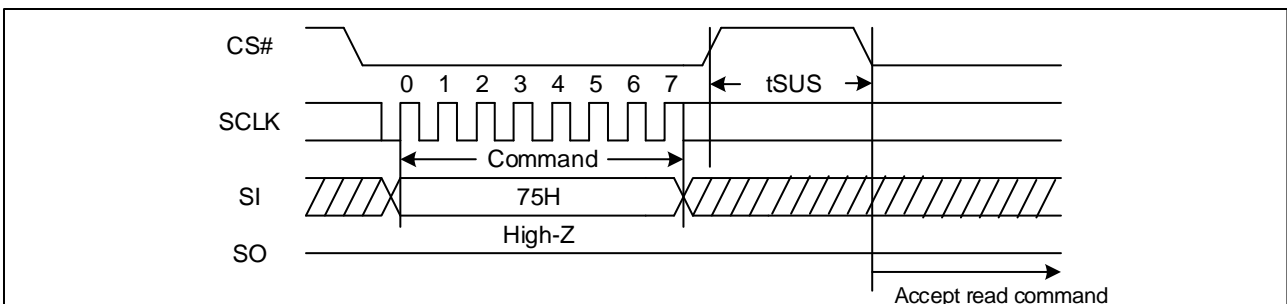
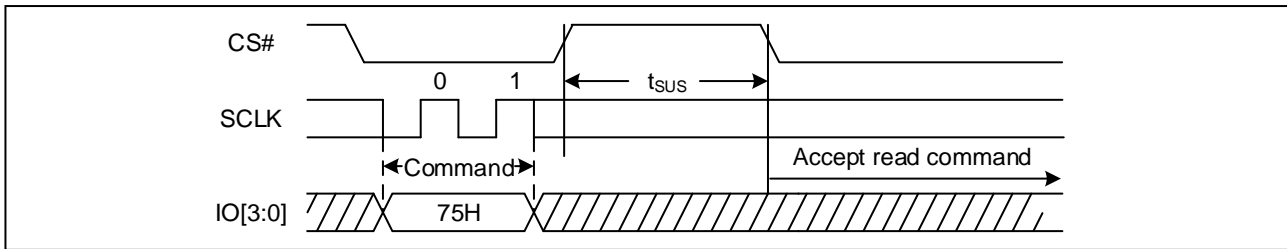

Figure 55. Program/Erase Suspend Sequence Diagram (QPI)



### 7.30 Program/Erase Resume (PER) (7AH)

The Program/Erase Resume command must be written to resume the program or sector/block erase operation after a Program/Erase Suspend command. The Program/Erase command will be accepted by the device only if the SUS1/SUS2 bit equal to 1 and the WIP bit equal to 0. After issued the SUS1/SUS2 bit in the status register will be cleared from 1 to 0 immediately, the WIP bit will be set from 0 to 1 within 200ns and the Sector or Block will complete the erase operation or the page will complete the program operation. The Program/Erase Resume command will be ignored unless a Program/Erase Suspend is active.

Figure 56. Program/Erase Resume Sequence Diagram (SPI)

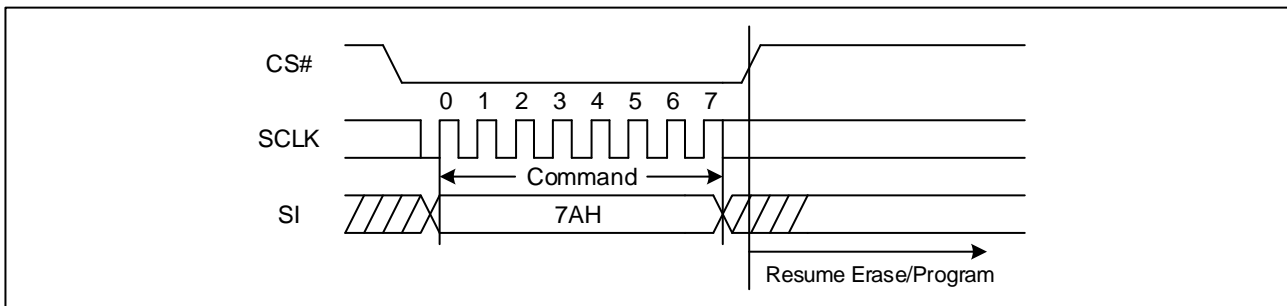
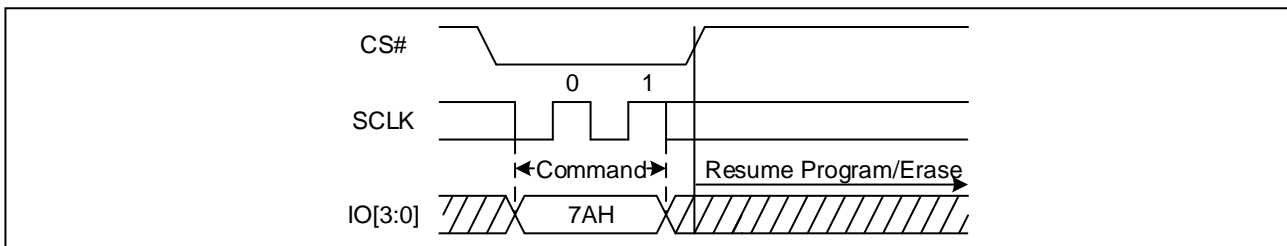

Figure 57. Program/Erase Resume Sequence Diagram (QPI)



### 7.31 Deep Power-Down (DP) (B9H)

Executing the Deep Power-Down (DP) command is the only way to put the device in the lowest consumption mode (the Deep Power-Down Mode). It can also be used as an extra software protection mechanism, while the device is not in active use, since in this mode, the device ignores all Write, Program and Erase commands. Driving CS# high deselects the device, and puts the device in the Standby Mode (if there is no internal cycle currently in progress). But this mode is not the Deep Power-Down Mode. The Deep Power-Down Mode can only be entered by executing the Deep Power-Down (DP) command. Once the device has entered the Deep Power-Down Mode, all commands are ignored except the Release from Deep Power-Down and Read Device ID (RDI) command or software reset command. The Release from Deep Power-Down and Read Device ID (RDI) command releases the device from Deep Power-Down mode, also allows the Device ID of the device to be output on SO.



The Deep Power-Down Mode automatically stops at Power-Down, and the device always in the Standby Mode after Power-Up.

The Deep Power-Down command sequence: CS# goes low → sending Deep Power-Down command → CS# goes high. CS# must be driven high after the eighth bit of the command code has been latched in; otherwise the Deep Power-Down (DP) command is not executed. As soon as CS# is driven high, it requires a delay of  $t_{DP}$  before the supply current is reduced to  $I_{CC2}$  and the Deep Power-Down Mode is entered. Any Deep Power-Down (DP) command, while an Erase, Program or Write cycle is in progress, is rejected without having any effects on the cycle that is in progress.

**Figure 58. Deep Power-Down Sequence Diagram (SPI)**

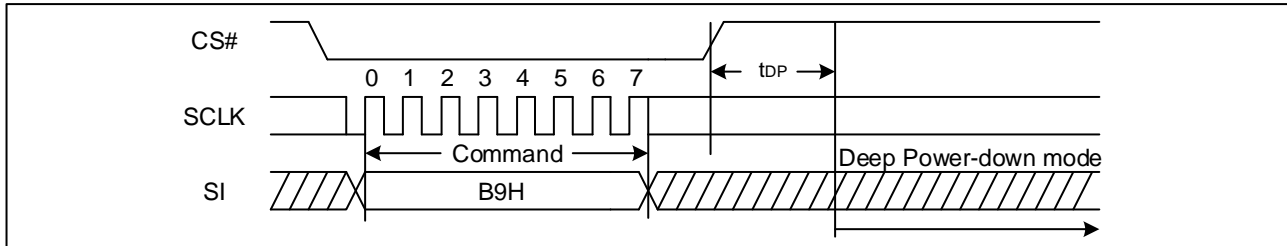

**Figure 59. Deep Power-Down Sequence Diagram (QPI)**

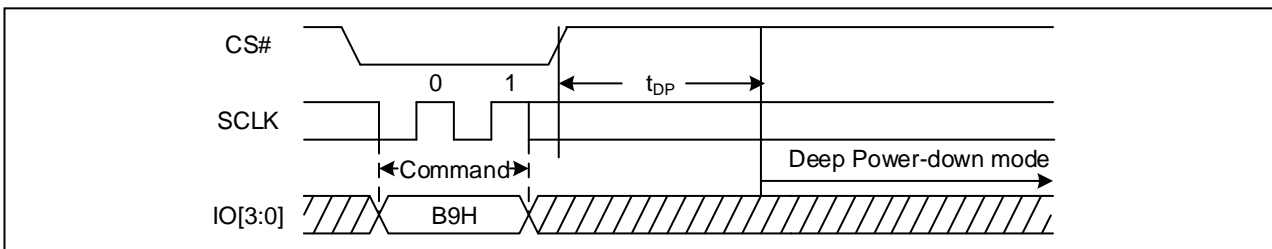

### 7.32 Release from Deep Power-Down and Read Device ID (RDI) (ABH)

The Release from Power-Down and Read Device ID command is a multi-purpose command. It can be used to release the device from the Power-Down state or obtain the devices electronic identification (ID) number.

To release the device from the Power-Down state, the command is issued by driving the CS# pin low, shifting the instruction code “ABH” and driving CS# high. Release from Power-Down will take the time duration of  $t_{RES1}$  (See AC Characteristics) before the device will resume normal operation and other command are accepted. The CS# pin must remain high during the  $t_{RES1}$  time duration.

When used only to obtain the Device ID while not in the Power-Down state, the command is initiated by driving the CS# pin low and shifting the instruction code “ABH” followed by 3-dummy byte. The Device ID bits are then shifted out on the falling edge of SCLK with most significant bit (MSB) first. The Device ID value is listed in Manufacturer and Device Identification table. The Device ID can be read continuously. The command is completed by driving CS# high.

When used to release the device from the Power-Down state and obtain the Device ID, the command is the same as previously described, except that after CS# is driven high it must remain high for a time duration of  $t_{RES2}$  (See AC Characteristics). After this time duration the device will resume normal operation and other command will be accepted. If the Release from Power-Down / Device ID command is issued while an Erase, Program or Write cycle is in process (when WIP equals 1) the command is ignored and will not have any effects on the current cycle.



**Figure 60. Release Power-Down Sequence Diagram (SPI)**

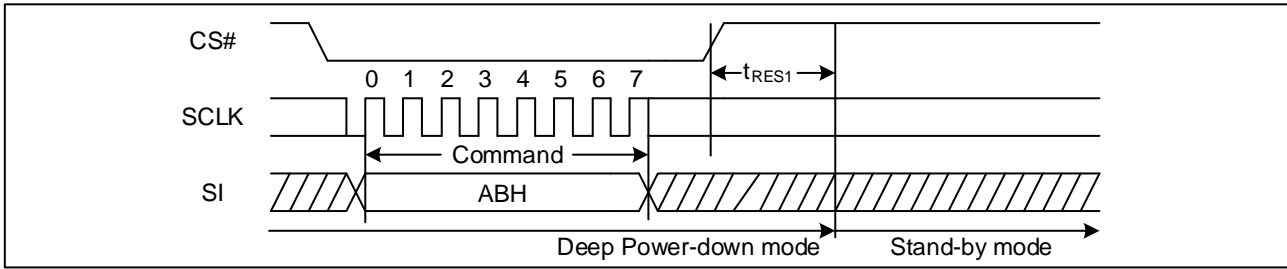

**Figure 61. Release Power-Down Sequence Diagram (QPI)**

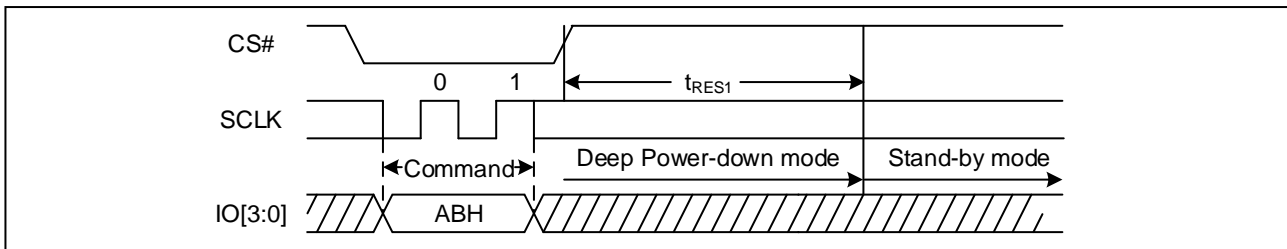

**Figure 62. Release Power-Down/Read Device ID Sequence Diagram (SPI)**

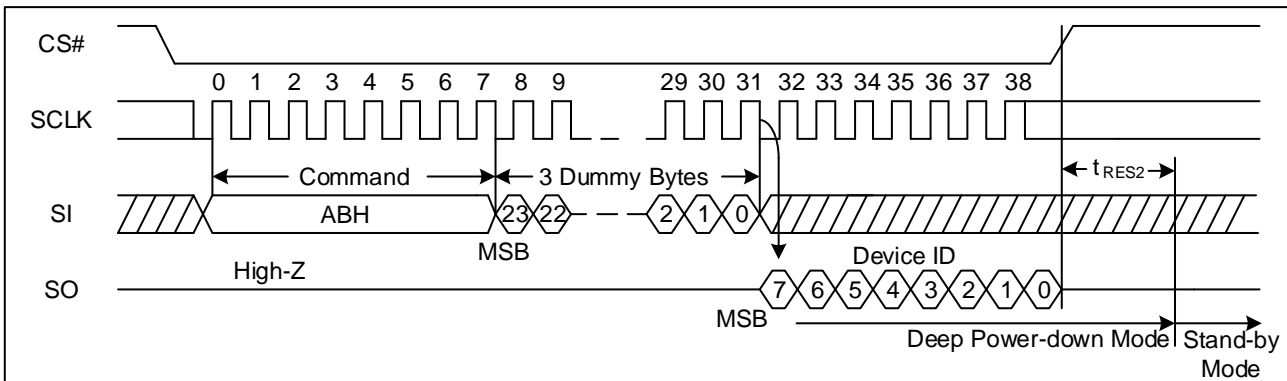

**Figure 63. Release Power-Down/Read Device ID Sequence Diagram (QPI)**

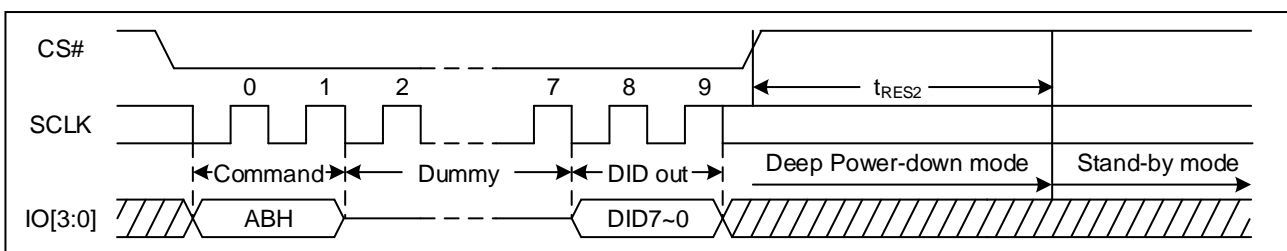

### 7.33 Enable QPI (38H)

The GD25LF128E supports both Standard/Dual/Quad SPI and QPI mode. The “Enable QPI (38H)” command can switch the device from SPI mode to QPI mode. In order to switch the device to QPI mode “Enable QPI (38H)” command must be issued. When the device is switched from SPI mode to QPI mode, the existing Write Enable Latch and Program/Erase Suspend status, and the Wrap Length setting will remain unchanged.



**Figure 64. Enable QPI mode command Sequence Diagram**

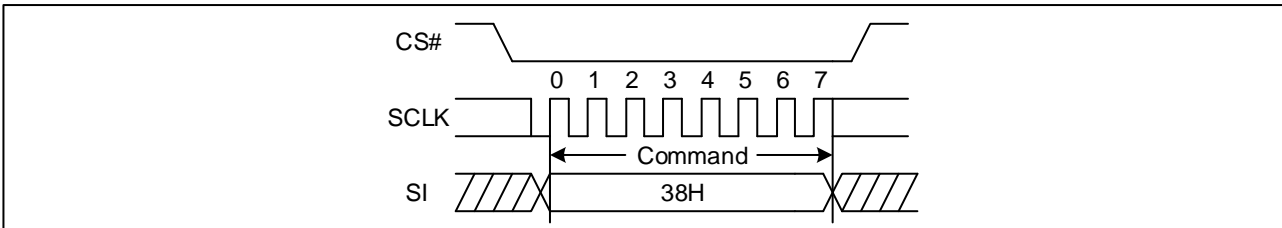

### 7.34 Disable QPI (FFH)

To exit the QPI mode and return to Standard/Dual/Quad SPI mode, the “Disable QPI (FFH)” command must be issued. When the device is switched from QPI mode to SPI mode, the existing Write Enable Latch and Program/Erase Suspend status, and the Wrap Length setting will remain unchanged.

**Figure 65. Disable QPI mode command Sequence Diagram**

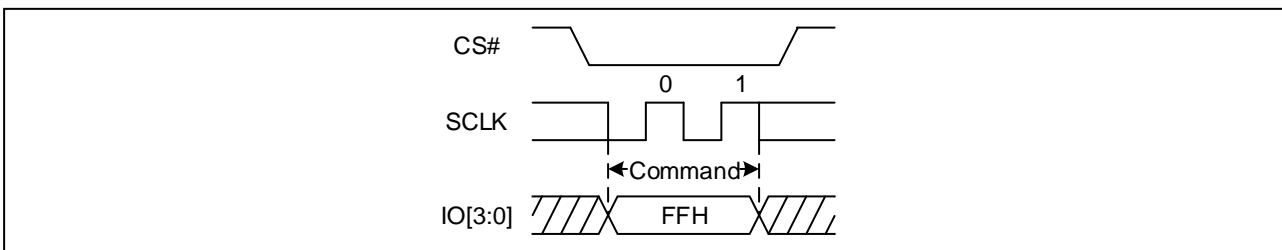

### 7.35 Read Serial Flash Discoverable Parameter (5AH)

The Serial Flash Discoverable Parameter (SFDP) standard provides a consistent method of describing the functional and feature capabilities of serial flash devices in a standard set of internal parameter tables. These parameter tables can be interrogated by host system software to enable adjustments needed to accommodate divergent features from multiple vendors. The concept is similar to the one found in the Introduction of JEDEC Standard, JESD68 on CFI. SFDP is a standard of JEDEC Standard No.216B.

**Figure 66. Read Serial Flash Discoverable Parameter command Sequence Diagram**

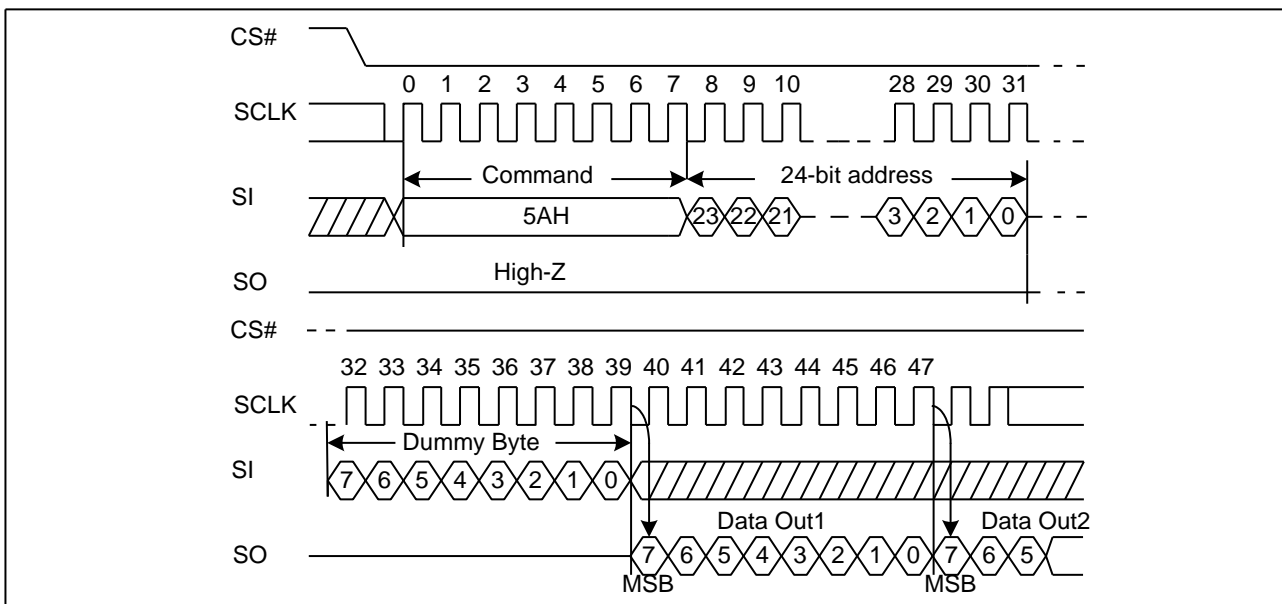



**Figure 67. Read Serial Flash Discoverable Parameter command Sequence Diagram (QPI)**

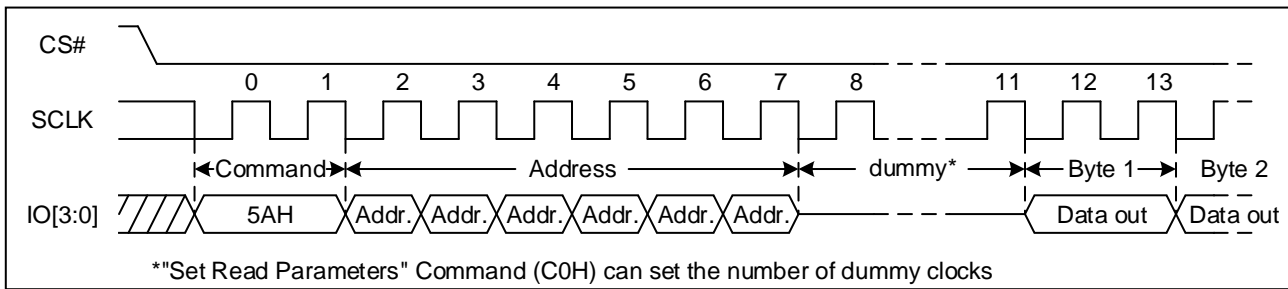

**Table 12. Signature and Parameter Identification Data Values (Please contact GigaDevice for Details)**



## 8 ELECTRICAL CHARACTERISTICS

### 8.1 Power-On Timing

Figure 68. Power-On Timing Sequence Diagram

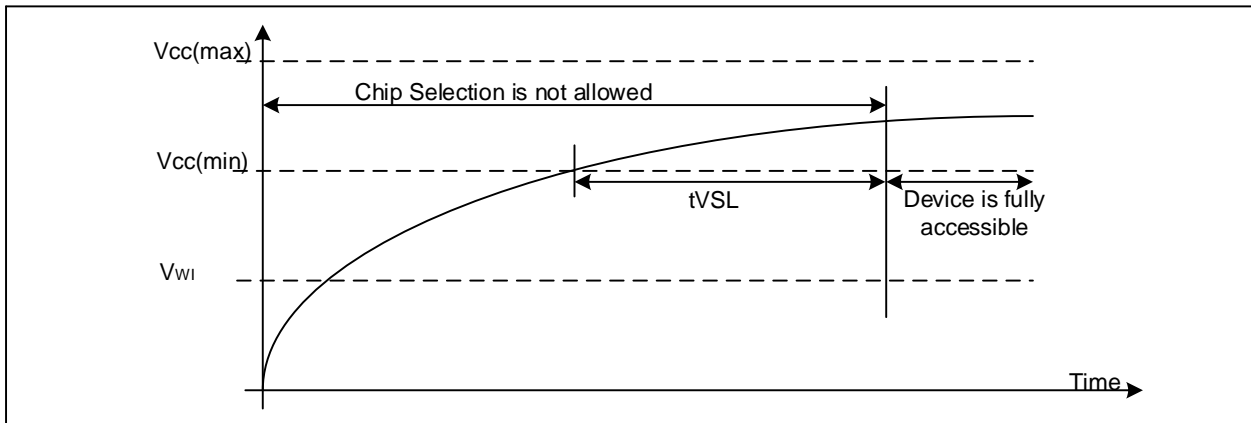

Table 13. Power-Up Timing and Write Inhibit Threshold

Symbol	Parameter	Min.	Max.	Unit
tVSL	VCC (min.) to device operation	1.8		ms
VWI	Write Inhibit Voltage	1	1.5	V

### 8.2 Initial Delivery State

The device is delivered with the memory array erased: all bits are set to 1 (each Byte contains FFH). The Status Register contains 00H, except that DRV0 bit (S21) and QE bit (S9) are set to 1.

### 8.3 Absolute Maximum Ratings

Parameter	Value	Unit
Ambient Operating Temperature (T <sub>A</sub> )	-40 to 85	°C
	-40 to 105	
	-40 to 125	
Storage Temperature	-65 to 150	°C
Transient Input/Output Voltage (note: overshoot)	-2.0 to VCC+2.0	V
Applied Input/Output Voltage	-0.6 to VCC+0.4	V
VCC	-0.6 to 2.5	V





Figure 69. Input Test Waveform and Measurement Level

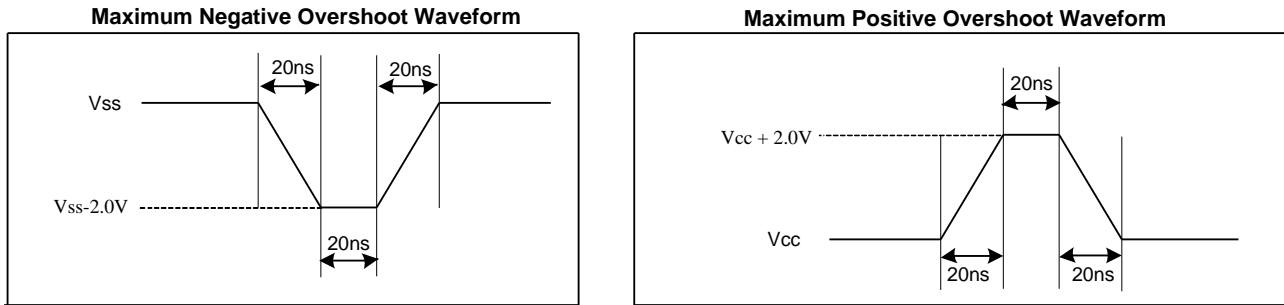

### 8.4 Capacitance Measurement Conditions

Symbol	Parameter	Min.	Typ.	Max.	Unit	Conditions
C <sub>IN</sub>	Input Capacitance			6	pF	V <sub>IN</sub> =0V
C <sub>OUT</sub>	Output Capacitance			8	pF	V <sub>OUT</sub> =0V
C <sub>L</sub>	Load Capacitance	30			pF	
	Input Rise And Fall time			5	ns	
	Input Pause Voltage	0.1V <sub>CC</sub> to 0.8V <sub>CC</sub>			V	
	Input Timing Reference Voltage	0.2V <sub>CC</sub> to 0.7V <sub>CC</sub>			V	
	Output Timing Reference Voltage	0.5V <sub>CC</sub>			V	

Figure 70. Absolute Maximum Ratings Diagram

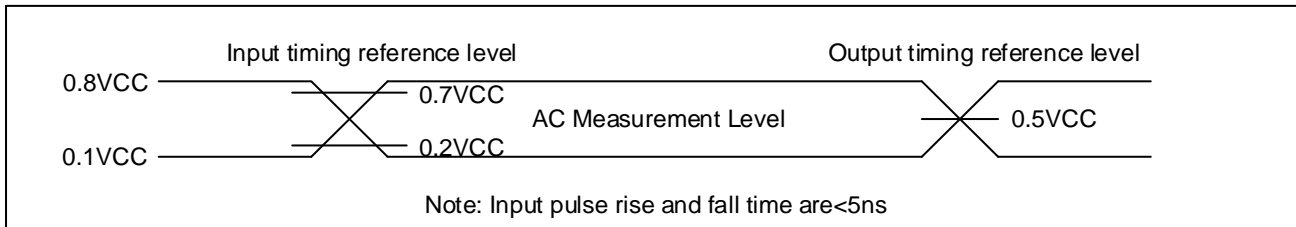



## 8.5 DC Characteristics

(T<sub>A</sub> = -40°C~85°C, VCC=1.65~2.0V)

Symbol	Parameter	Test Condition	Min.	Typ.	Max.	Unit.
I <sub>LI</sub>	Input Leakage Current				±2	μA
I <sub>LO</sub>	Output Leakage Current				±2	μA
I <sub>CC1</sub>	Standby Current	CS#=VCC, VIN=VCC or VSS		11	50	μA
I <sub>CC2</sub>	Deep Power-Down Current	CS#=VCC, VIN=VCC or VSS		1	10	μA
I <sub>CC3</sub>	Operating Current (Read)	CLK=0.1VCC / 0.9VCC at 166MHz, Q=Open(x4 I/O)		7	10	mA
		CLK=0.1VCC / 0.9VCC at 80MHz, Q=Open(x4 I/O)		4	6	mA
		CLK=0.1VCC / 0.9VCC at 104MHz DTR, Q=Open(x4 I/O)		8	11	mA
I <sub>CC4</sub>	Operating Current (PP)	CS#=VCC		12	20	mA
I <sub>CC5</sub>	Operating Current (WRSR)	CS#=VCC		12	20	mA
I <sub>CC6</sub>	Operating Current (SE)	CS#=VCC		12	20	mA
I <sub>CC7</sub>	Operating Current (BE)	CS#=VCC		12	20	mA
I <sub>CC8</sub>	Operating Current (CE)	CS#=VCC		12	20	mA
V <sub>IL</sub>	Input Low Voltage				0.2VCC	V
V <sub>IH</sub>	Input High Voltage		0.7VCC			V
V <sub>OL</sub>	Output Low Voltage	I <sub>OL</sub> = 100μA			0.2	V
V <sub>OH</sub>	Output High Voltage	I <sub>OH</sub> = -100μA	VCC-0.2			V

Note:

1. Typical value at T<sub>A</sub> = 25°C, VCC = 1.8V.
2. Value guaranteed by design and/or characterization, not 100% tested in production.



(T<sub>A</sub> = -40°C~105°C, VCC=1.65~2.0V)

Symbol	Parameter	Test Condition	Min.	Typ.	Max.	Unit.
I <sub>LI</sub>	Input Leakage Current				±2	μA
I <sub>LO</sub>	Output Leakage Current				±2	μA
I <sub>CC1</sub>	Standby Current	CS#=VCC, VIN=VCC or VSS		11	100	μA
I <sub>CC2</sub>	Deep Power-Down Current	CS#=VCC, VIN=VCC or VSS		1	35	μA
I <sub>CC3</sub>	Operating Current (Read)	CLK=0.1VCC / 0.9VCC at 166MHz, Q=Open(x4 I/O)		7	13	mA
		CLK=0.1VCC / 0.9VCC at 80MHz, Q=Open(x4 I/O)		4	9	mA
		CLK=0.1VCC / 0.9VCC at 104MHz DTR, Q=Open(x4 I/O)		8	14	mA
I <sub>CC4</sub>	Operating Current (PP)	CS#=VCC		12	23	mA
I <sub>CC5</sub>	Operating Current (WRSR)	CS#=VCC		12	23	mA
I <sub>CC6</sub>	Operating Current (SE)	CS#=VCC		12	23	mA
I <sub>CC7</sub>	Operating Current (BE)	CS#=VCC		12	23	mA
I <sub>CC8</sub>	Operating Current (CE)	CS#=VCC		12	23	mA
V <sub>IL</sub>	Input Low Voltage				0.2VCC	V
V <sub>IH</sub>	Input High Voltage		0.7VCC			V
V <sub>OL</sub>	Output Low Voltage	I <sub>OL</sub> = 100μA			0.2	V
V <sub>OH</sub>	Output High Voltage	I <sub>OH</sub> = -100μA	VCC-0.2			V

**Note:**

1. Typical value at T<sub>A</sub> = 25°C, VCC = 1.8V.
2. Value guaranteed by design and/or characterization, not 100% tested in production.



(T<sub>A</sub> = -40°C~125°C, VCC=1.65~2.0V)

Symbol	Parameter	Test Condition	Min.	Typ.	Max.	Unit.
I <sub>LI</sub>	Input Leakage Current				±2	μA
I <sub>LO</sub>	Output Leakage Current				±2	μA
I <sub>CC1</sub>	Standby Current	CS#=VCC, VIN=VCC or VSS		11	150	μA
I <sub>CC2</sub>	Deep Power-Down Current	CS#=VCC, VIN=VCC or VSS		1	50	μA
I <sub>CC3</sub>	Operating Current (Read)	CLK=0.1VCC / 0.9VCC at 166MHz, Q=Open(x4 I/O)		7	13	mA
		CLK=0.1VCC / 0.9VCC at 80MHz, Q=Open(x4 I/O)		4	9	mA
		CLK=0.1VCC / 0.9VCC at 104MHz DTR, Q=Open(x4 I/O)		8	14	mA
I <sub>CC4</sub>	Operating Current (PP)	CS#=VCC		12	23	mA
I <sub>CC5</sub>	Operating Current (WRSR)	CS#=VCC		12	23	mA
I <sub>CC6</sub>	Operating Current (SE)	CS#=VCC		12	23	mA
I <sub>CC7</sub>	Operating Current (BE)	CS#=VCC		12	23	mA
I <sub>CC8</sub>	Operating Current (CE)	CS#=VCC		12	23	mA
V <sub>IL</sub>	Input Low Voltage				0.2VCC	V
V <sub>IH</sub>	Input High Voltage		0.7VCC			V
V <sub>OL</sub>	Output Low Voltage	I <sub>OL</sub> = 100μA			0.2	V
V <sub>OH</sub>	Output High Voltage	I <sub>OH</sub> = -100μA	VCC-0.2			V

**Note:**

1. Typical value at T<sub>A</sub> = 25°C, VCC = 1.8V.
2. Value guaranteed by design and/or characterization, not 100% tested in production.



## 8.6 AC Characteristics

(T<sub>A</sub> = -40°C~85°C, VCC=1.65~2.0V)

Symbol	Parameter	Min.	Typ.	Max.	Unit.
f <sub>C1</sub>	Serial Clock Frequency For: all commands except Read (03H) and DTR Quad I/O Fast Read (EDH)			166	MHz
f <sub>C2</sub>	Serial Clock Frequency For: EDH			104	MHz
f <sub>R</sub>	Serial Clock Frequency For: 03H			80	MHz
t <sub>CLH</sub>	Serial Clock High Time	45% (1/f <sub>CMax</sub> )			ns
t <sub>CLL</sub>	Serial Clock Low Time	45% (1/f <sub>CMax</sub> )			ns
t <sub>CLCH</sub>	Serial Clock Rise Time (Slew Rate)	0.2			V/ns
t <sub>CHCL</sub>	Serial Clock Fall Time (Slew Rate)	0.2			V/ns
t <sub>SLCH</sub>	CS# Active Setup Time	5			ns
t <sub>CHSH</sub>	CS# Active Hold Time	5			ns
t <sub>SHCH</sub>	CS# Not Active Setup Time	5			ns
t <sub>CHSL</sub>	CS# Not Active Hold Time	5			ns
t <sub>SHSL</sub>	CS# High Time (Read/Write)	20			ns
t <sub>SHQZ</sub>	Output Disable Time			6	ns
t <sub>CLQX</sub> t <sub>CHQX</sub>	Output Hold Time	1.2			ns
t <sub>DVCH</sub> t <sub>DVCL</sub>	Data In Setup Time	2			ns
t <sub>CHDX</sub> t <sub>CLDX</sub>	Data In Hold Time	2			ns
t <sub>CLQV</sub> t <sub>CHQV</sub>	Clock Low To Output Valid (CL = 30pF)			7	ns
	Clock Low To Output Valid (CL = 15pF)			6	ns
	Clock Low To Output Valid (CL = 10pF)			5.5	ns
t <sub>DP</sub>	CS# High To Deep Power-Down Mode			3	μs
t <sub>RES1</sub>	CS# High To Standby Mode Without Electronic Signature Read			20	μs
t <sub>RES2</sub>	CS# High To Standby Mode With Electronic Signature Read			20	μs
t <sub>SUS</sub>	CS# High To Next Command After Suspend			20	μs
t <sub>RS</sub> <sup>(3)</sup>	Latency Between Resume And Next Suspend	100			μs
t <sub>RST</sub>	CS# High To Next Command After Reset (Except From Erase)			30	μs
t <sub>RST_E</sub>	CS# High To Next Command After Reset (From Erase)			12	ms
t <sub>W</sub>	Write Status Register Cycle Time		2	25	ms
t <sub>BP1</sub>	Byte Program Time (First Byte)		30	60	μs
t <sub>BP2</sub>	Additional Byte Program Time (After First Byte)		2.5	5	μs



t <sub>PP</sub>	Page Programming Time		0.25	2.4	ms
t <sub>SE</sub>	Sector Erase Time		30	300	ms
t <sub>BE1</sub>	Block Erase Time (32K Bytes)		0.1	0.8	s
t <sub>BE2</sub>	Block Erase Time (64K Bytes)		0.15	1.2	s
t <sub>CE</sub>	Chip Erase Time (GD25LF128E)		32	80	s

Note:

1. Typical value at T<sub>A</sub> = 25°C.
2. Value guaranteed by design and/or characterization, not 100% tested in production.
3. Minimum timing must be observed before issuing the next suspend command, and a period equal to or longer than the minimum timing is required in order for the program or erase operation to make progress, but the operation time may exceed the maximum value.



(T<sub>A</sub> = -40°C~105°C, VCC=1.65~2.0V)

Symbol	Parameter	Min.	Typ.	Max.	Unit.
f <sub>C1</sub>	Serial Clock Frequency For: all commands except Read (03H) and DTR Quad I/O Fast Read (EDH)			166	MHz
f <sub>C2</sub>	Serial Clock Frequency For: EDH			104	MHz
f <sub>R</sub>	Serial Clock Frequency For: 03H			80	MHz
t <sub>CLH</sub>	Serial Clock High Time	45% (1/f <sub>CMax</sub> )			ns
t <sub>CLL</sub>	Serial Clock Low Time	45% (1/f <sub>CMax</sub> )			ns
t <sub>CLCH</sub>	Serial Clock Rise Time (Slew Rate)	0.2			V/ns
t <sub>CHCL</sub>	Serial Clock Fall Time (Slew Rate)	0.2			V/ns
t <sub>SLCH</sub>	CS# Active Setup Time	5			ns
t <sub>CHSH</sub>	CS# Active Hold Time	5			ns
t <sub>SHCH</sub>	CS# Not Active Setup Time	5			ns
t <sub>CHSL</sub>	CS# Not Active Hold Time	5			ns
t <sub>SHSL</sub>	CS# High Time (Read/Write)	20			ns
t <sub>SHQZ</sub>	Output Disable Time			6	ns
t <sub>CLQX</sub> t <sub>CHQX</sub>	Output Hold Time	1.2			ns
t <sub>DVCH</sub> t <sub>DVCL</sub>	Data In Setup Time	2			ns
t <sub>CHDX</sub> t <sub>CLDX</sub>	Data In Hold Time	2			ns
t <sub>CLQV</sub> t <sub>CHQV</sub>	Clock Low To Output Valid (CL = 30pF)			7	ns
	Clock Low To Output Valid (CL = 15pF)			6	ns
	Clock Low To Output Valid (CL = 10pF)			5.5	ns
t <sub>DP</sub>	CS# High To Deep Power-Down Mode			3	μs
t <sub>RES1</sub>	CS# High To Standby Mode Without Electronic Signature Read			20	μs
t <sub>RES2</sub>	CS# High To Standby Mode With Electronic Signature Read			20	μs
t <sub>SUS</sub>	CS# High To Next Command After Suspend			20	μs
t <sub>RS</sub> <sup>(3)</sup>	Latency Between Resume And Next Suspend	100			μs
t <sub>RST</sub>	CS# High To Next Command After Reset (Except From Erase)			30	μs
t <sub>RST_E</sub>	CS# High To Next Command After Reset (From Erase)			12	ms
t <sub>W</sub>	Write Status Register Cycle Time		2	30	ms
t <sub>BP1</sub>	Byte Program Time (First Byte)		30	60	μs
t <sub>BP2</sub>	Additional Byte Program Time (After First Byte)		2.5	5	μs
t <sub>PP</sub>	Page Programming Time		0.25	2.4	ms



t <sub>SE</sub>	Sector Erase Time		30	400	ms
t <sub>BE1</sub>	Block Erase Time (32K Bytes)		0.1	1.2	s
t <sub>BE2</sub>	Block Erase Time (64K Bytes)		0.15	2.4	s
t <sub>CE</sub>	Chip Erase Time (GD25LF128E)		32	120	s

Note:

1. Typical value at T<sub>A</sub> = 25°C.
2. Value guaranteed by design and/or characterization, not 100% tested in production.
3. Minimum timing must be observed before issuing the next suspend command, and a period equal to or longer than the minimum timing is required in order for the program or erase operation to make progress, but the operation time may exceed the maximum value.





(T<sub>A</sub> = -40°C~125°C, VCC=1.65~2.0V)

Symbol	Parameter	Min.	Typ.	Max.	Unit.
f <sub>C1</sub>	Serial Clock Frequency For: all commands except Read (03H) and DTR Quad I/O Fast Read (EDH)			133	MHz
f <sub>C2</sub>	Serial Clock Frequency For: EDH			90	MHz
f <sub>R</sub>	Serial Clock Frequency For: 03H			80	MHz
t <sub>CLH</sub>	Serial Clock High Time	45% (1/f <sub>CMax</sub> )			ns
t <sub>CLL</sub>	Serial Clock Low Time	45% (1/f <sub>CMax</sub> )			ns
t <sub>CLCH</sub>	Serial Clock Rise Time (Slew Rate)	0.2			V/ns
t <sub>CHCL</sub>	Serial Clock Fall Time (Slew Rate)	0.2			V/ns
t <sub>SLCH</sub>	CS# Active Setup Time	5			ns
t <sub>CHSH</sub>	CS# Active Hold Time	5			ns
t <sub>SHCH</sub>	CS# Not Active Setup Time	5			ns
t <sub>CHSL</sub>	CS# Not Active Hold Time	5			ns
t <sub>SHSL</sub>	CS# High Time (Read/Write)	20			ns
t <sub>SHQZ</sub>	Output Disable Time			6	ns
t <sub>CLQX</sub> t <sub>CHQX</sub>	Output Hold Time	1.2			ns
t <sub>DVCH</sub> t <sub>DVCL</sub>	Data In Setup Time	2			ns
t <sub>CHDX</sub> t <sub>CLDX</sub>	Data In Hold Time	2			ns
t <sub>CLQV</sub> t <sub>CHQV</sub>	Clock Low To Output Valid (CL = 30pF)			7	ns
	Clock Low To Output Valid (CL = 15pF)			6	ns
	Clock Low To Output Valid (CL = 10pF)			5.5	ns
t <sub>DP</sub>	CS# High To Deep Power-Down Mode			3	μs
t <sub>RES1</sub>	CS# High To Standby Mode Without Electronic Signature Read			20	μs
t <sub>RES2</sub>	CS# High To Standby Mode With Electronic Signature Read			20	μs
t <sub>SUS</sub>	CS# High To Next Command After Suspend			20	μs
t <sub>RS</sub> <sup>(3)</sup>	Latency Between Resume And Next Suspend	100			μs
t <sub>RST</sub>	CS# High To Next Command After Reset (Except From Erase)			30	μs
t <sub>RST_E</sub>	CS# High To Next Command After Reset (From Erase)			12	ms
t <sub>W</sub>	Write Status Register Cycle Time		2	50	ms
t <sub>BP1</sub>	Byte Program Time (First Byte)		30	100	μs
t <sub>BP2</sub>	Additional Byte Program Time (After First Byte)		2.5	10	μs
t <sub>PP</sub>	Page Programming Time		0.25	4	ms



$t_{SE}$	Sector Erase Time		30	500	ms
$t_{BE1}$	Block Erase Time (32K Bytes)		0.1	1.5	s
$t_{BE2}$	Block Erase Time (64K Bytes)		0.15	3	s
$t_{CE}$	Chip Erase Time (GD25LF128E)		32	150	s

Note:

1. Typical value at  $T_A = 25^\circ\text{C}$ .
2. Value guaranteed by design and/or characterization, not 100% tested in production.
3. Minimum timing must be observed before issuing the next suspend command, and a period equal to or longer than the minimum timing is required in order for the program or erase operation to make progress, but the operation time may exceed the maximum value.

**Figure 71. Input Timing**

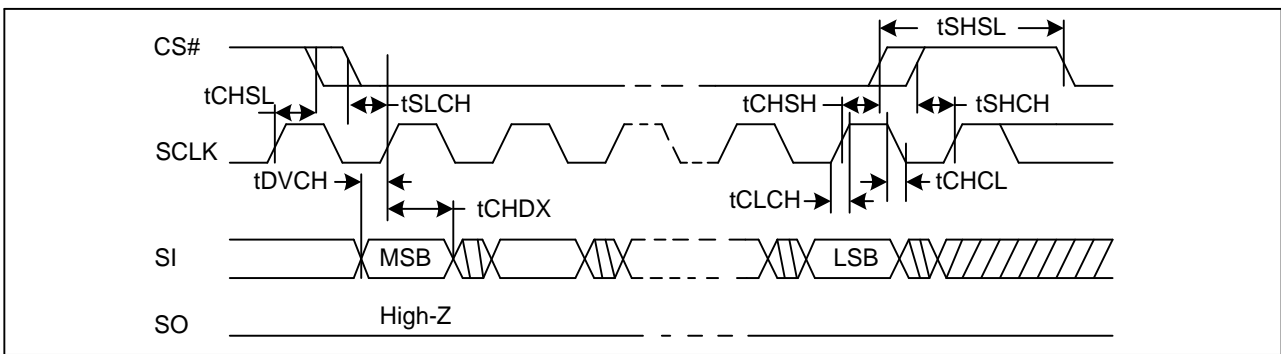

**Figure 72. Output Timing**

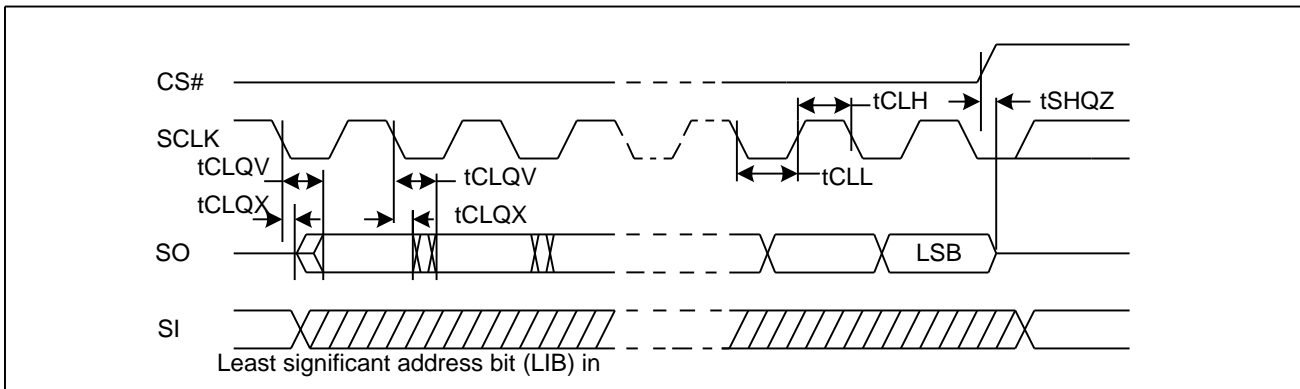

**Figure 73. Serial Input Timing (DTR)**

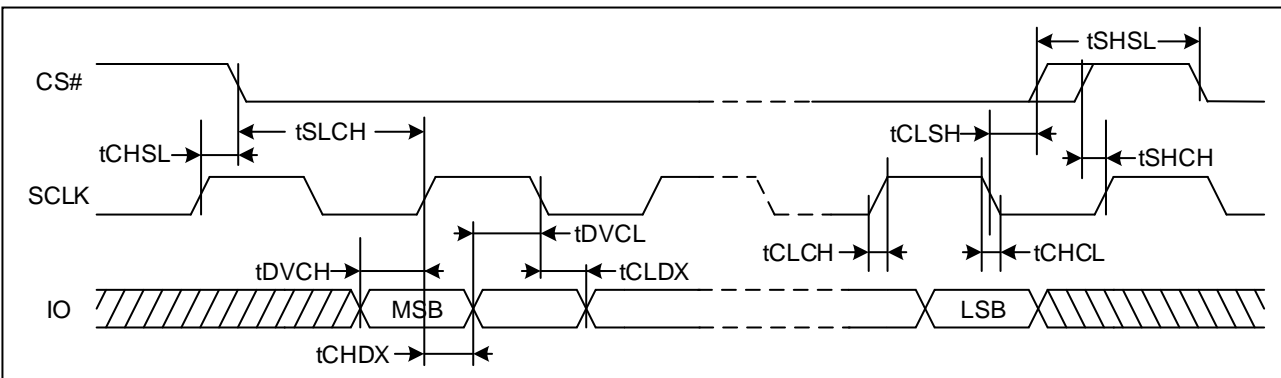



Figure 74. Serial Output Timing (DTR)

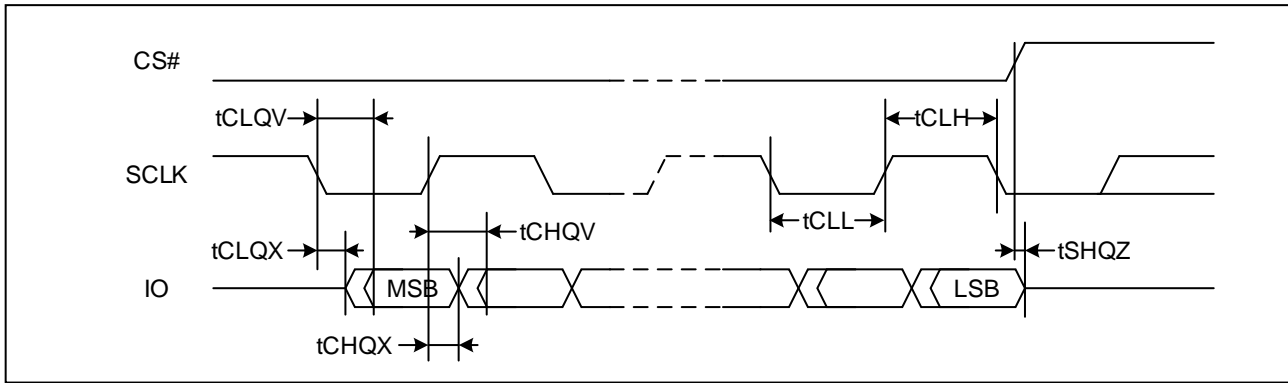

Figure 75. Resume to Suspend Timing Diagram

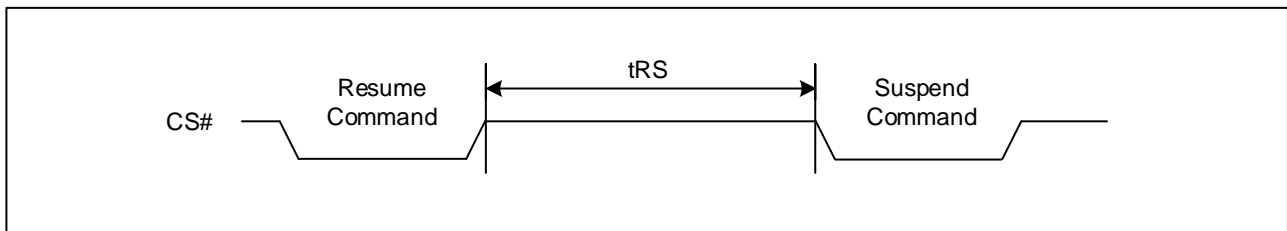

Figure 76 RESET Timing

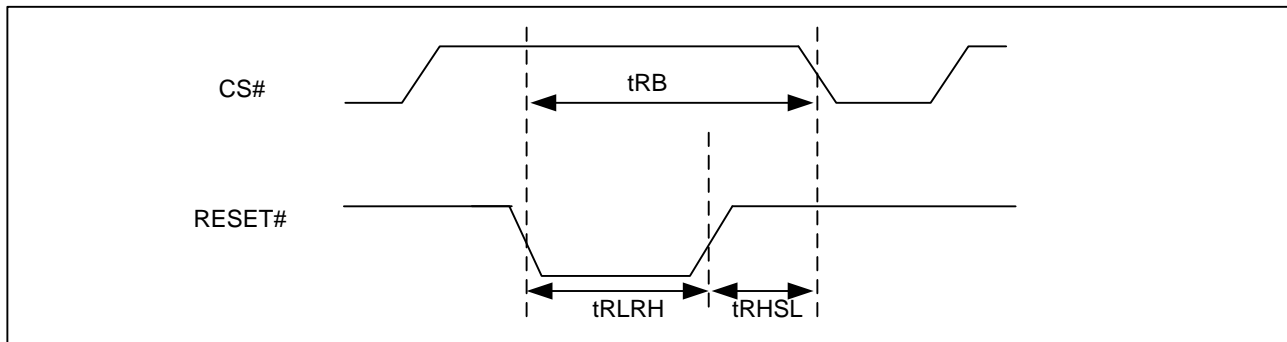

Table 14 Reset Timing

Symbol	Parameter	Min.	Typ.	Max.	Unit.
tRLRH	Reset Pulse Width	1			μs
tRHSL	Reset High Time Before Read	50			ns
tRB	Reset Recovery Time			12	ms

Note:

1. The device need tRB (max) at most to get ready for all commands after RESET# low.



## 9 ORDERING INFORMATION

**GD XX XX XX X X X X X**

**Packing**

T or no mark: Tube  
Y: Tray  
R: Tape and Reel

**Green Code**

G: Pb Free + Halogen Free Green Package  
S: Pb Free + Halogen Free Green Package + SRP1 Function  
R: Pb Free + Halogen Free Green Package + RESET# Pin  
K: Pb Free + Halogen Free Green Package + RESET# Pin + SRP1 Function

**Temperature Range**

I: Industrial (-40°C to +85°C)  
J: Industrial+ (-40°C to +105°C)  
E: Industrial+ (-40°C to +125°C)  
F: Industrial+ (-40°C to +85°C)\*\*

**Package Type**

S: SOP8 208mil  
Q: USON8 (4x4mm)  
W: WSON8 (6x5mm)  
B: TFBGA-24ball (5x5 Ball Array)

**Generation**

E: E Version

**Density**

128: 128M bit

**Series**

LF: 1.8V, 4KB Uniform Sector, default x4I/O

**Product Family**

25: SPI NOR Flash

**\*\*F grade has implemented additional test flows to ensure higher product quality than I grade.**



## 9.1 Valid Part Numbers

Please contact GigaDevice regional sales for the latest product selection and available form factors.

### Temperature Range I: Industrial (-40°C to +85°C)

Product Number	Density	Package Type	Packing Options
GD25LF128ESIG	128Mbit	SOP8 208mil	T/Y/R
GD25LF128ESIS			
GD25LF128EQIG	128Mbit	USON8 (4x4mm)	Y/R
GD25LF128EQIS			
GD25LF128EWIG	128Mbit	WSON8 (6x5mm)	Y/R
GD25LF128EWIS			
GD25LF128EBIR	128Mbit	TFBGA-24ball (5x5 Ball Array)	Y/R
GD25LF128EBIK			

### Temperature Range J: Industrial (-40°C to +105°C)

Product Number	Density	Package Type	Packing Options
GD25LF128ESJG	128Mbit	SOP8 208mil	T/Y/R
GD25LF128ESJS			
GD25LF128EQJG	128Mbit	USON8 (4x4mm)	Y/R
GD25LF128EQJS			
GD25LF128EWJG	128Mbit	WSON8 (6x5mm)	Y/R
GD25LF128EWJS			
GD25LF128EBJR	128Mbit	TFBGA-24ball (5x5 Ball Array)	Y/R
GD25LF128EBJK			



**Temperature Range E: Industrial (-40°C to +125°C)**

Product Number	Density	Package Type	Packing Options
GD25LF128ESEG	128Mbit	SOP8 208mil	T/Y/R
GD25LF128ESES			
GD25LF128EQEG	128Mbit	USON8 (4x4mm)	Y/R
GD25LF128EQES			
GD25LF128EWEG	128Mbit	WSON8 (6x5mm)	Y/R
GD25LF128EWES			
GD25LF128EBER	128Mbit	TFBGA-24ball (5x5 Ball Array)	Y/R
GD25LF128EBEK			

**Temperature Range F: Industrial+ (-40°C to +85°C)**

Product Number	Density	Package Type	Packing Options
GD25LF128ESFG	128Mbit	SOP8 208mil	T/Y/R
GD25LF128ESFS			
GD25LF128EQFG	128Mbit	USON8 (4x4mm)	Y/R
GD25LF128EQFS			
GD25LF128EWFG	128Mbit	WSON8 (6x5mm)	Y/R
GD25LF128EWFS			
GD25LF128EBFR	128Mbit	TFBGA-24ball (5x5 Ball Array)	Y/R
GD25LF128EBFK			



## 10 PACKAGE INFORMATION

### 10.1 Package SOP8 208MIL

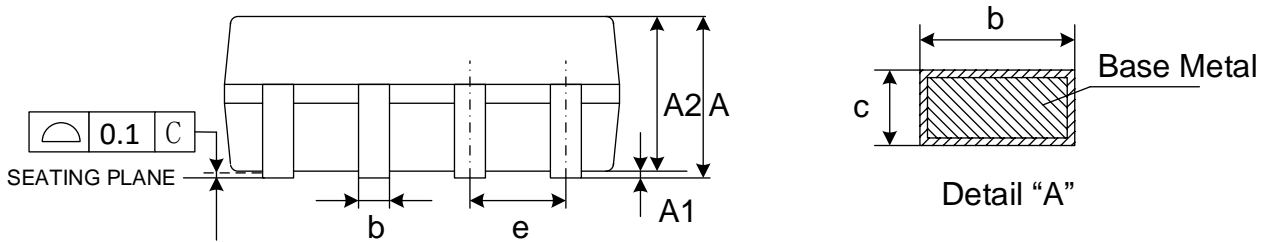
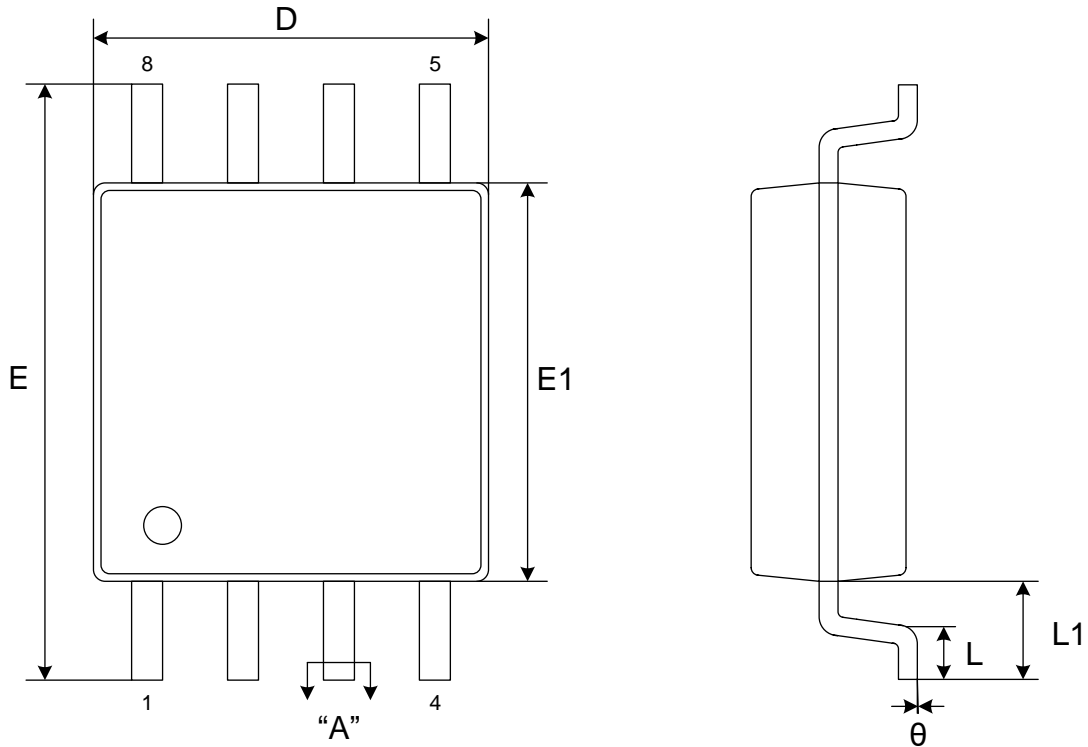

### Dimensions

Symbol	A	A1	A2	b	c	D	E	E1	e	L	L1	$\theta$	
Unit													
mm	Min	-	0.05	1.70	0.31	0.15	5.13	7.70	5.18	1.27	0.50	1.31	0°
	Nom	-	0.15	1.80	0.41	0.20	5.23	7.90	5.28		-		-
	Max	2.16	0.25	1.90	0.51	0.25	5.33	8.10	5.38		0.85		8°

Notes:

- Both the package length and width do not include the mold flash.



## 10.2 Package USON8 (4x4mm)

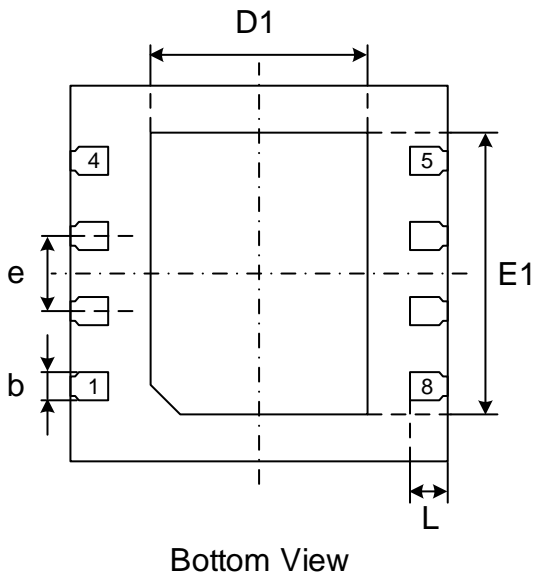
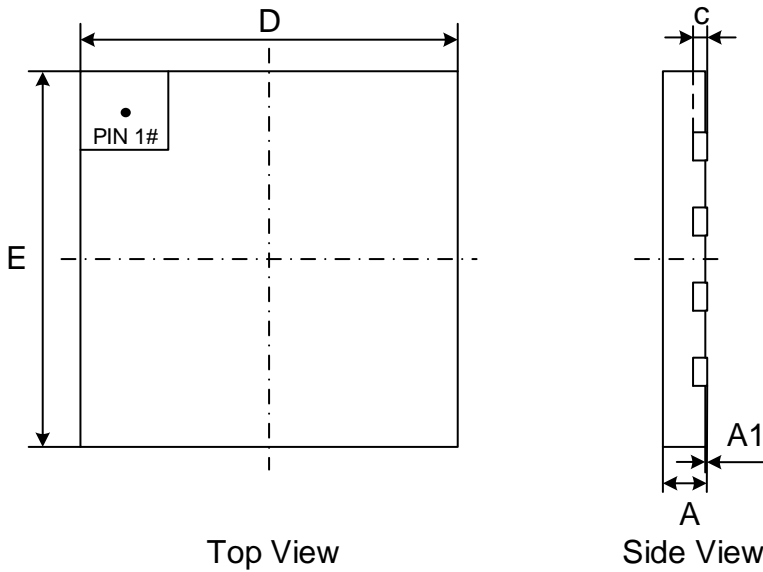

### Dimensions

Symbol		A	A1	c	b	D	D1	E	E1	e	L
Unit											
mm	Min	0.40	0.00	0.10	0.25	3.90	2.20	3.90	2.90	0.80	0.35
	Nom	0.45	0.02	0.15	0.30	4.00	2.30	4.00	3.00		0.40
	Max	0.50	0.05	0.20	0.35	4.10	2.40	4.10	3.10		0.45

Note:

1. The exposed metal pad area on the bottom of the package is floating.
2. Coplanarity  $\leq 0.08\text{mm}$ . Package edge tolerance  $\leq 0.10\text{mm}$ .
3. The lead shape may be of little difference according to different package factories. These lead shapes are compatible with each other





### 10.3 Package WSON8 (6x5mm)

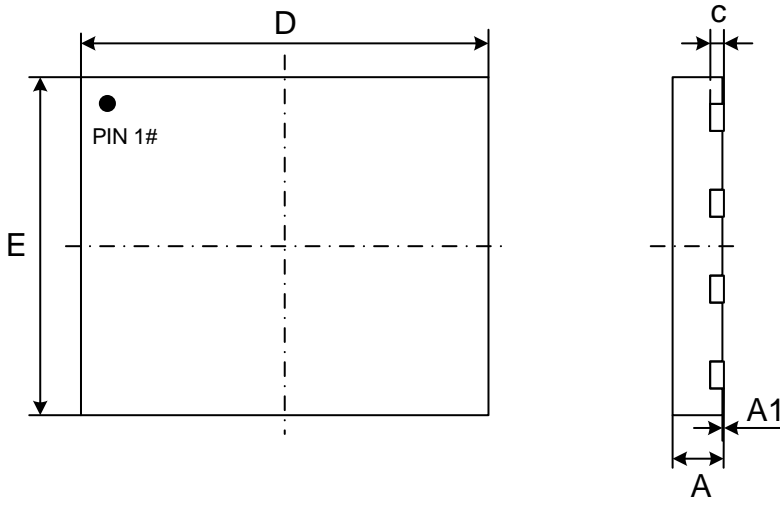

Top View

Side View

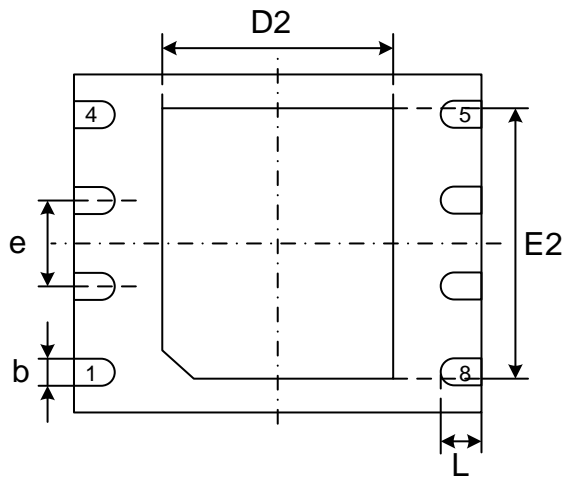

Bottom View

#### Dimensions

Symbol		A	A1	c	b	D	D2	E	E2	e	L
Unit											
mm	Min	0.70	0.00	0.180	0.35	5.90	3.30	4.90	3.90	1.27	0.50
	Nom	0.75	0.02	0.203	0.40	6.00	3.40	5.00	4.00		0.60
	Max	0.80	0.05	0.250	0.50	6.10	3.50	5.10	4.10		0.75

Note:

1. The exposed metal pad area on the bottom of the package is floating.
2. Coplanarity  $\leq 0.08\text{mm}$ . Package edge tolerance  $\leq 0.10\text{mm}$ .
3. The lead shape may be of little difference according to different package lead frames. These lead shapes are compatible with each other.



**10.4 Package TFBGA-24BALL (5x5 ball array)**

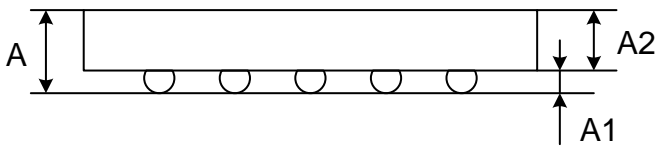
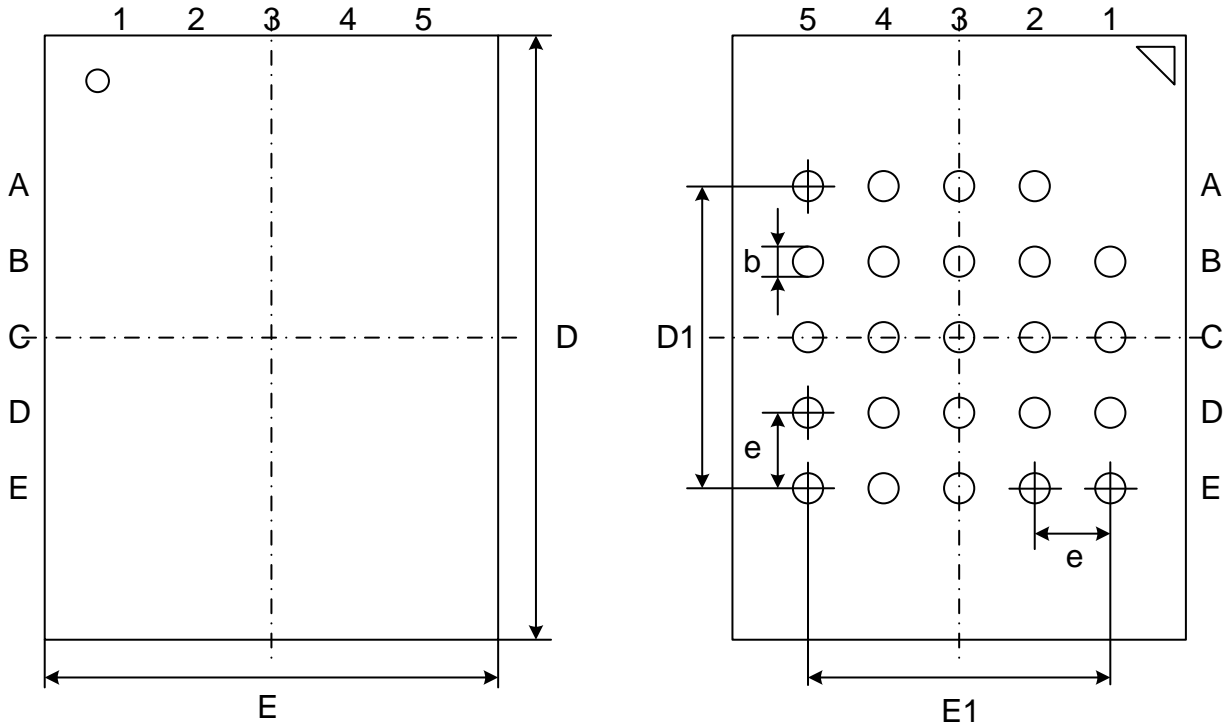

**Dimensions**

Symbol		A	A1	A2	b	E	E1	D	D1	e
Unit										
mm	Min	-	0.25	-	0.35	5.90	4.00	7.90	4.00	1.00
	Nom	-	0.30	0.80	0.40	6.00		8.00		
	Max	1.20	0.35	-	0.45	6.10		8.10		



## 11 REVISION HISTORY

Version No	Description	Page	Date
1.0	Initial release	All	2020-6-11
1.1	Add DTR input/output timing diagram	P57, 58	2020-9-14
1.2	Remove “with 30PF load”	P4	2021-8-13
	Add note 2 about reset pin	P6	
	Modify dummy clock number of figure 23	P28	
1.3	Add Note of IO2 and IO3	P5-7	2023-6-1
	Modify Description of C0H Command	P32	
	Add Note of $t_{RS}$	P53-58	
	Update Ordering Information	P60-62	
	Add Coplanarity of SOP8 208mil Package	P63	
Modify Dimensions Table of TFBGA-24BALL Package	P66		

## Important Notice

This document is the property of GigaDevice Semiconductor Inc. and its subsidiaries (the "Company"). This document, including any product of the Company described in this document (the "Product"), is owned by the Company under the intellectual property laws and treaties of the People's Republic of China and other jurisdictions worldwide. The Company reserves all rights under such laws and treaties and does not grant any license under its patents, copyrights, trademarks, or other intellectual property rights. The names and brands of third party referred thereto (if any) are the property of their respective owner and referred to for identification purposes only.

The Company makes no warranty of any kind, express or implied, with regard to this document or any Product, including, but not limited to, the implied warranties of merchantability and fitness for a particular purpose. The Company does not assume any liability arising out of the application or use of any Product described in this document. Any information provided in this document is provided only for reference purposes. It is the responsibility of the user of this document to properly design, program, and test the functionality and safety of any application made of this information and any resulting product. Except for customized products which has been expressly identified in the applicable agreement, the Products are designed, developed, and/or manufactured for ordinary business, industrial, personal, and/or household applications only. The Products are not designed, intended, or authorized for use as components in systems designed or intended for the operation of weapons, weapons systems, nuclear installations, atomic energy control instruments, combustion control instruments, airplane or spaceship instruments, traffic signal instruments, life-support devices or systems, other medical devices or systems (including resuscitation equipment and surgical implants), pollution control or hazardous substances management, or other uses where the failure of the device or Product could cause personal injury, death, property or environmental damage ("Unintended Uses"). Customers shall take any and all actions to ensure using and selling the Products in accordance with the applicable laws and regulations. The Company is not liable, in whole or in part, and customers shall and hereby do release the Company as well as its suppliers and/or distributors from any claim, damage, or other liability arising from or related to all Unintended Uses of the Products. Customers shall indemnify and hold the Company as well as its suppliers and/or distributors harmless from and against all claims, costs, damages, and other liabilities, including claims for personal injury or death, arising from or related to any Unintended Uses of the Products. Customers shall discard the device according to the local environmental law.

**Information in this document is provided solely in connection with the Products. The Company reserves the right to make changes, corrections, modifications or improvements to this document and the Products and services described herein at any time, without notice.**