2x25W Stereo / 1x50W Mono Digital Audio Amplifier With 30 bands EQ and DRC Functions

Features

- 16/18/20/24-bits input with I²S, Left-alignment and Right-alignment data format
- PSNR & DR(A-weighting)
Loudspeaker: 108dB (PSNR), 108dB (DR)@24V
- Multiple sampling frequencies (Fs)
8kHz and 32kHz / 44.1kHz / 48kHz and
64kHz / 88.2kHz / 96kHz and
128kHz / 176.4kHz / 192kHz
- System clock = 64x, 128x, 192x, 256x, 384x,
512x, 576x, 768x, 1024x Fs
MCLK system:
256x~4096x Fs for 8kHz
64x~1024x Fs for 32kHz / 44.1kHz / 48kHz
64x~512x Fs for 64kHz / 88.2kHz / 96kHz
64x~256x Fs for 128kHz / 176.4kHz / 192kHz
BCLK system:
64x Fs for 32kHz / 44.1kHz / 48kHz
64x Fs for 64kHz / 88.2kHz / 96kHz
64x Fs for 128kHz / 176.4kHz / 192kHz
- Supply voltage
3.3V for digital circuit
4.5V~26V for loudspeaker driver
- Supports 2.0CH/Mono configuration
- Loudspeaker output power@12V for stereo
7W x 2CH into 8Ω <1% THD+N
10W x 2CH into 4Ω <1% THD+N
- Loudspeaker output power@18V for stereo
15W x 2CH into 8Ω <1% THD+N
- Loudspeaker output power@24V for stereo
25W x 2CH into 8Ω <1% THD+N
- Sound processing including :
30 bands parametric speaker EQ
Volume control (+24dB~-103dB, 0.125dB/step)
Dynamic range control
Three Band plus post Dynamic range control
Power Clipping
Programmed 3D surround sound
Channel mixing
Noise gate with hysteresis window
Bass/Treble tone control
DC-blocking high-pass filter

- Pre-scale/post-scale
- Anti-pop design
- Level meter and power meter
- I2S output with selectable Audio DSP point
- Short circuit and over-temperature protection
- Supports I²C control without clock
- I²C control interface with selectable device address
- Support hardware and software reset
- Internal PLL
- LV Under-voltage shutdown and HV Under-voltage detection
- Over voltage protection
- Power saving mode

Applications

- TV audio
- Boom-box, CD and DVD receiver, docking system
- Powered speaker
- Wireless audio

Description

AD82584F is a digital audio amplifier capable of driving 25W (BTL) each to a pair of 8Ω load speaker and 50W (PBTL) to a 4Ω load speaker operating at 24V supply without external heat-sink or fan requirement with play music. AD82584F provides advanced audio processing functions, such as volume control, 30 EQ bands, audio mixing, 3D surround sound and Dynamic Range Control (DRC). These are fully programmable via a simple I²C control interface. Robust protection circuits are provided to protect AD82584F from damage due to accidental erroneous operating condition. The full digital circuit design of AD82584F is more tolerant to noise and PVT (Process, Voltage, and Temperature) variation than the analog class-AB or class-D audio amplifier counterpart implemented by analog circuit design. AD82584F is pop free during instantaneous power on/off or mute/shut down switching because of its robust built-in anti-pop circuit.

Pin Assignment

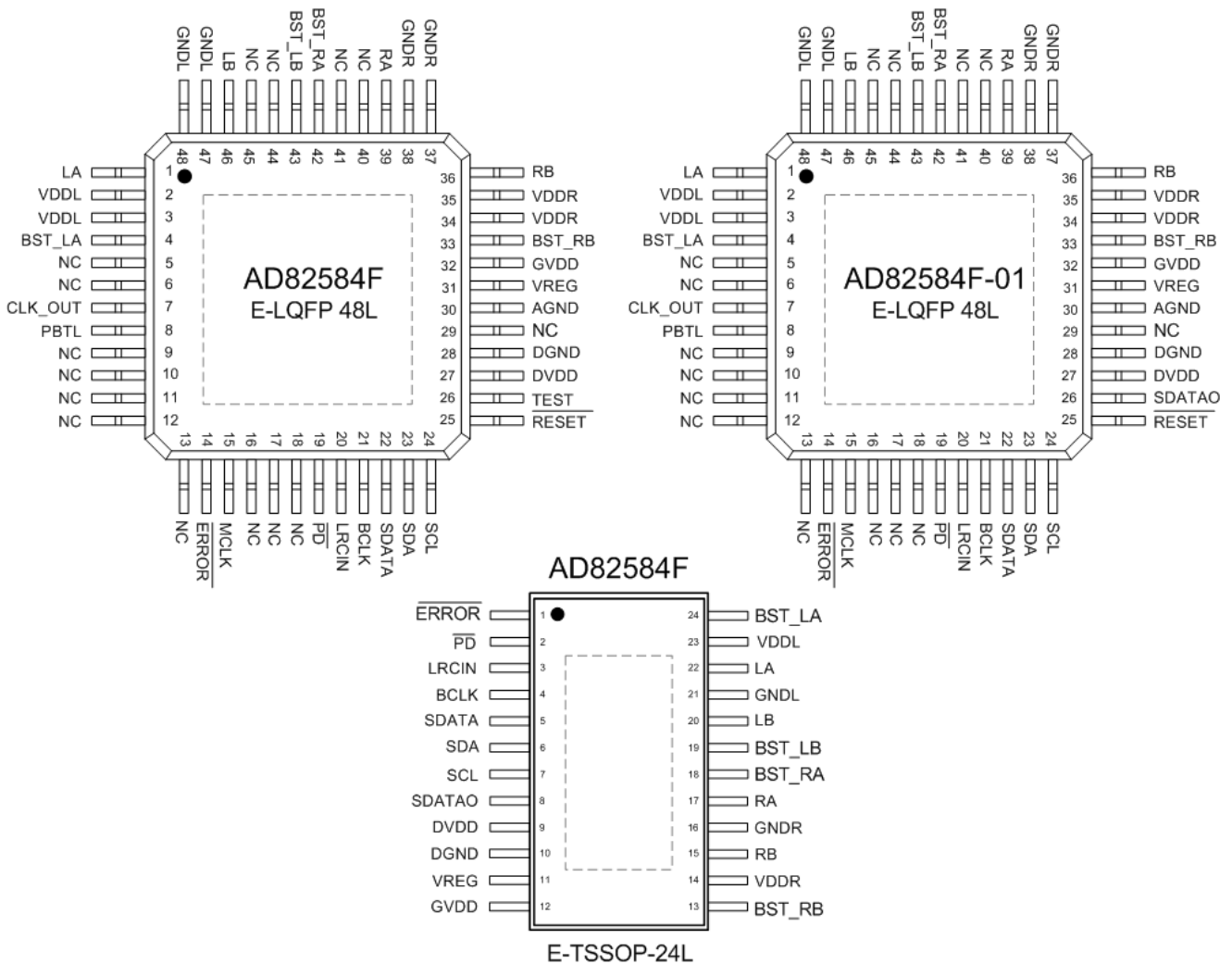

Pin Description (E-LQFP 48L)

PIN	NAME	TYPE	DESCRIPTION	CHARACTERISTICS
1	LA	O	Left channel output A.	
2	VDDL	P	Left channel supply.	
3	VDDL	P	Left channel supply.	
4	BST_LA	P	Bootstrap supply for left channel output A.	
5	NC		Not connected.	
6	NC		Not connected.	
7	CLK_OUT	I/O	PLL ratio setting pin during power up, this pin is monitored on the rising edge of reset. PMF register will be default set at 1 or 16 times PLL ratio.	TTL output buffer, internal pull Low with a 100Kohm resistor.

			High: PMF [3:0] = [0000], 1 time of PLL ratio to avoid system BCLK over flow. Low: PMF [3:0] = [0001], 16 times of PLL ratio. This pin could be clock output pin also during normal operating if EN_CLK_OUT register bit is enabled.	
8	PBTL	I	Stereo/Mono configuration pin. (Low: Stereo ; High: Mono)	TTL output buffer, internal pull Low with a 100Kohm resistor.
9	NC		Not connected.	
10	NC		Not connected.	
11	NC		Not connected.	
12	NC		Not connected.	
13	NC		Not connected.	
14	$\overline{\text{ERROR}}$	I/O	$\overline{\text{ERROR}}$ pin is a dual function pin. One is I ² C address setting during power up. The other one is error status report (low active), It sets by register of A_SEL_FAULT at address 0x1C B[6] to enable it.	This pin is monitored on the rising edge of reset. A value of Low (15-k Ω pull down) sets the I ² C device address to 0x30 and a value of High (15-k Ω pull up) sets it to 0x31.
15	MCLK	I	Master clock input.	Schmitt trigger TTL input buffer, internal pull Low with a 100Kohm resistor.
16	NC		Not connected.	
17	NC		Not connected.	
18	NC		Not connected.	
19	$\overline{\text{PD}}$	I	Power down, low active.	Schmitt trigger TTL input buffer, internal pull High with a 330Kohm resistor.
20	LRCIN	I	Left/Right clock input (Fs).	Schmitt trigger TTL input buffer, internal pull Low with a 100Kohm resistor.
21	BCLK	I	Bit clock input.	Schmitt trigger TTL input buffer, internal pull Low with a 100Kohm resistor.
22	SDATA	I	Serial audio data input.	Schmitt trigger TTL input buffer
23	SDA	I/O	I ² C bi-directional serial data.	Schmitt trigger TTL input buffer
24	SCL	I	I ² C serial clock input.	Schmitt trigger TTL input buffer

25	$\overline{\text{RESET}}$	I	Reset, low active.	Schmitt trigger TTL input buffer, internal pull High with a 330Kohm resistor.
26	TEST	I	This pin must connect to GND.	
27	DVDD	P	Digital Power.	
28	DGND	P	Digital Ground.	
29	NC		Not connected.	
30	AGND	P	Analog Ground.	
31	VREG	O	1.8V Regulator voltage output.	
32	GVDD	O	5V Regulator voltage output. This pin must not be used to drive external devices.	
33	BST_RB	P	Bootstrap supply for right channel output B.	
34	VDDR	P	Right channel supply.	
35	VDDR	P	Right channel supply.	
36	RB	O	Right channel output B.	
37	GNDR	P	Right channel ground.	
38	GNDR	P	Right channel ground.	
39	RA	O	Right channel output A.	
40	NC		Not connected.	
41	NC		Not connected.	
42	BST_RA	P	Bootstrap supply for right channel output A.	
43	BST_LB	P	Bootstrap supply for left channel output B.	
44	NC		Not connected.	
45	NC		Not connected.	
46	LB	O	Left channel output B.	
47	GNDL	P	Left channel ground.	
48	GNDL	P	Left channel ground.	

Pin Description (01-E-LQFP 48L)

PIN	NAME	TYPE	DESCRIPTION	CHARACTERISTICS
1	LA	O	Left channel output A.	
2	VDDL	P	Left channel supply.	
3	VDDL	P	Left channel supply.	
4	BST_LA	P	Bootstrap supply for left channel output A.	
5	NC		Not connected.	
6	NC		Not connected.	

7	CLK_OUT	I/O	<p>PLL ratio setting pin during power up, this pin is monitored on the rising edge of reset. PMF register will be default set at 1 or 16 times PLL ratio.</p> <p>High: PMF [3:0] = [0000], 1 time of PLL ratio to avoid system BCLK over flow.</p> <p>Low: PMF [3:0] = [0001], 16 times of PLL ratio.</p> <p>This pin could be clock output pin also during normal operating if EN_CLK_OUT register bit is enabled.</p>	TTL output buffer, internal pull Low with a 100Kohm resistor.
8	PBTL	I	<p>Stereo/Mono configuration pin. (Low: Stereo ; High: Mono)</p>	TTL output buffer, internal pull Low with a 100Kohm resistor.
9	NC		Not connected.	
10	NC		Not connected.	
11	NC		Not connected.	
12	NC		Not connected.	
13	NC		Not connected.	
14	$\overline{\text{ERROR}}$	I/O	<p>$\overline{\text{ERROR}}$ pin is a dual function pin. One is I²C address setting during power up. The other one is error status report (low active), It sets by register of A_SEL_FAULT at address 0x1C B[6] to enable it.</p>	This pin is monitored on the rising edge of reset. A value of Low (15-kΩ pull down) sets the I ² C device address to 0x30 and a value of High (15-kΩ pull up) sets it to 0x31.
15	MCLK	I	Master clock input.	Schmitt trigger TTL input buffer, internal pull Low with a 100Kohm resistor.
16	NC		Not connected.	
17	NC		Not connected.	
18	NC		Not connected.	
19	$\overline{\text{PD}}$	I	Power down, low active.	Schmitt trigger TTL input buffer, internal pull High with a 330Kohm resistor.
20	LRCIN	I	Left/Right clock input (Fs).	Schmitt trigger TTL input buffer, internal pull Low with a 100Kohm resistor.
21	BCLK	I	Bit clock input (64Fs).	Schmitt trigger TTL input buffer, internal pull Low with a 100Kohm

				resistor.
22	SDATA	I	Serial audio data input.	Schmitt trigger TTL input buffer
23	SDA	I/O	I ² C bi-directional serial data.	Schmitt trigger TTL input buffer
24	SCL	I	I ² C serial clock input.	Schmitt trigger TTL input buffer
25	$\overline{\text{RESET}}$	I	Reset, low active.	Schmitt trigger TTL input buffer, internal pull High with a 330Kohm resistor.
26	SDATAO	O	Serial audio data output.	Schmitt trigger TTL input buffer
27	DVDD	P	Digital Power.	
28	DGND	P	Digital Ground.	
29	NC		Not connected.	
30	AGND	P	Analog Ground.	
31	VREG	O	1.8V Regulator voltage output.	
32	GVDD	O	5V Regulator voltage output. This pin must not be used to drive external devices.	
33	BST_RB	P	Bootstrap supply for right channel output B.	
34	VDDR	P	Right channel supply.	
35	VDDR	P	Right channel supply.	
36	RB	O	Right channel output B.	
37	GNDR	P	Right channel ground.	
38	GNDR	P	Right channel ground.	
39	RA	O	Right channel output A.	
40	NC		Not connected.	
41	NC		Not connected.	
42	BST_RA	P	Bootstrap supply for right channel output A.	
43	BST_LB	P	Bootstrap supply for left channel output B.	
44	NC		Not connected.	
45	NC		Not connected.	
46	LB	O	Left channel output B.	
47	GNDL	P	Left channel ground.	
48	GNDL	P	Left channel ground.	

Pin Description (E-TSSOP 24L)

PIN	NAME	TYPE	DESCRIPTION	CHARACTERISTICS
1	$\overline{\text{ERROR}}$	I/O	$\overline{\text{ERROR}}$ pin is a dual function pin. One is I ² C address setting during power up. The other one is error status report (low active), It sets by register of A_SEL_FAULT at address 0x1C B[6] to enable it.	This pin is monitored on the rising edge of reset. A value of Low (15-k Ω pull down) sets the I ² C device address to 0x30 and a value of High (15-k Ω pull up) sets it to 0x31.
2	$\overline{\text{PD}}$	I	Power down, low active.	Schmitt trigger TTL input buffer, internal pull High with a 330Kohm resistor.
3	LRCIN	I	Left/Right clock input (Fs).	Schmitt trigger TTL input buffer, internal pull Low with a 100Kohm resistor.
4	BCLK	I	Bit clock input (64Fs).	Schmitt trigger TTL input buffer, internal pull Low with a 100Kohm resistor.
5	SDATA	I	Serial audio data input.	Schmitt trigger TTL input buffer
6	SDA	I/O	I ² C bi-directional serial data.	Schmitt trigger TTL input buffer
7	SCL	I	I ² C serial clock input.	Schmitt trigger TTL input buffer
8	SDATAO	O	Serial audio data output.	Schmitt trigger TTL input buffer
9	DVDD	P	Digital Power.	
10	DGND	P	Digital Ground.	
11	VREG	O	1.8V Regulator voltage output.	
12	GVDD	O	5V Regulator voltage output. This pin must not be used to drive external devices.	
13	BST_RB	P	Bootstrap supply for right channel output B.	
14	VDDR	P	Right channel supply.	
15	RB	O	Right channel output B.	
16	GNDR	P	Right channel ground.	
17	RA	O	Right channel output A.	
18	BST_RA	P	Bootstrap supply for right channel output A.	
19	BST_LB	P	Bootstrap supply for left channel output B.	
20	LB	O	Left channel output B.	
21	GNDL	P	Left channel ground.	
22	LA	O	Left channel output A.	
23	VDDL	P	Left channel supply.	
24	BST_LA	P	Bootstrap supply for left channel output A.	

Functional Block Diagram

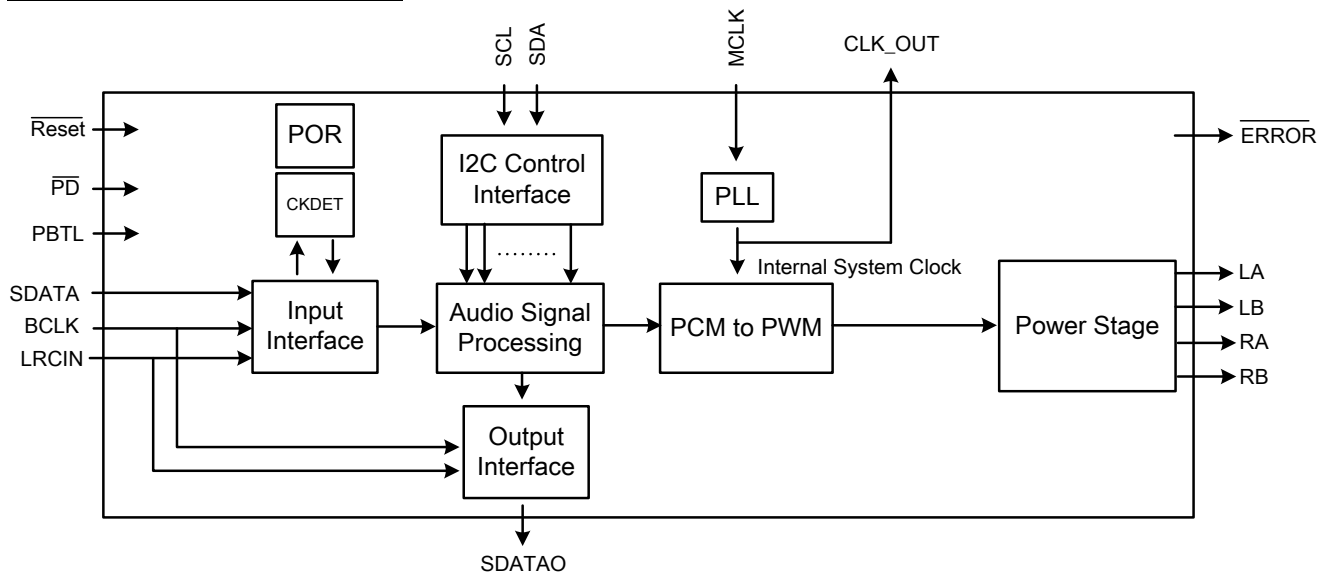

Ordering Information

Product ID	Package	Packing / MPQ	Comments
AD82584F-LG48NRY	E-LQFP 48L (7mmx7mm)	250 Units / Tray 2.5K Units / Box (10 Trays)	Green
AD82584F-LG48NRR	E-LQFP 48L (7mmx7mm)	2K Units / Reel 1 Reel / Small box	Green
AD82584F-01LG48NRY (by request)	E-LQFP 48L (7mmx7mm)	250 Units / Tray 2.5K Units / Box (10 Tray)	Green
AD82584F-01LG48NRR (by request)	E-LQFP 48L (7mmx7mm)	2k Units / Reel 1 reel / Small box	Green
AD82584F-QG24NRT	E-TSSOP 24L	62 Units / Tube 100 Tubes / Small box	Green
AD82584F-QG24NRR	E-TSSOP 24L	2.5K Units / Reel 1 Reel / Small box	Green

Available Package

Package Type	Device No.	θ_{ja} (°C/W)	Ψ_{jt} (°C/W)	θ_{jt} (°C/W)	Exposed Thermal Pad
E-LQFP 48L	AD82584F	22.9	1.64	34.9	Yes (Note1)
E-TSSOP 24L		26.8	1.83	27.1	

Note 1.1: The thermal pad is located at the bottom of the package. To optimize thermal performance, soldering the thermal pad to the PCB's ground plane is suggested.

Note 1.2: θ_{ja} , the junction-to-ambient thermal resistance is simulated on a room temperature ($T_A=25^\circ\text{C}$), natural convection environment test board, which is constructed with a thermally efficient, 4-layers PCB (2S2P). The simulation is tested using the JESD51-5 thermal measurement standard.

Note 1.3: Ψ_{jt} represents the thermal parameter for the heat flow between the chip junction and the package's top surface center. It's extracted from the simulation data for obtaining θ_{ja} , using a procedure described in JESD51-2.

Note 1.4: θ_{jt} represents the thermal resistance for the heat flow between the chip junction and the package's top surface. It's extracted from the simulation data with obtaining a cold plate on the package top.

Marking Information

AD82584F

Line 1 : LOGO

Line 2 : Product no.

Line 3 : Tracking Code

Line 4 : Date Code

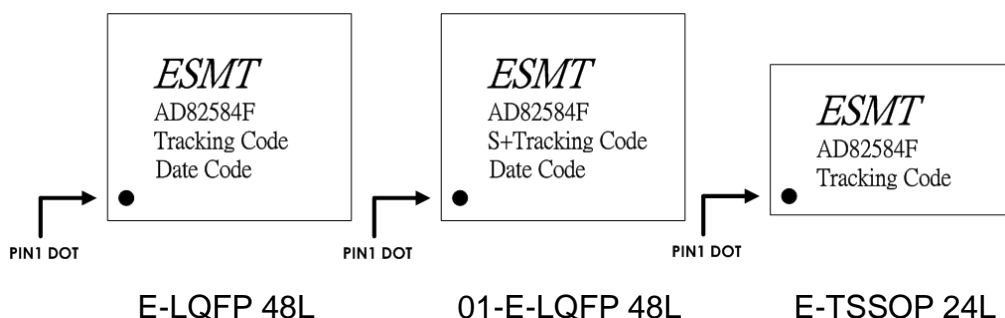

Absolute Maximum Ratings (AMR)

Stresses beyond those listed under *absolute maximum ratings* may cause permanent damage to the device.

Symbol	Parameter	Min	Max	Units
DVDD	Supply for Digital Circuit	-0.3	3.6	V
VDDL/R	Supply for Driver Stage	-0.3	30	V
	Output Pin (LA, LB, RA and RB) to GND		32	V
V_i	Input Voltage	-0.3	3.6	V
T_{stg}	Storage Temperature	-65	150	°C
T_J	Junction Operating Temperature	-40	150	°C
ESD	Human Body Model		±2K	V
	Charged Device Model		±750	V

Recommended Operating Conditions

Symbol	Parameter	Typ	Units
DVDD	Supply for Digital Circuit	3.15~3.45	V
VDDL/R	Supply for Driver Stage	4.5~26	V
T _J	Junction Operating Temperature	-40~125	°C
T _A	Ambient Operating Temperature	-40~85	°C

General Electrical Characteristics

Condition: T_A=25 °C (unless otherwise specified).

Symbol	Parameter	Condition	Min	Typ	Max	Units
I _{PD} (HV)	PVDD Supply Current during Power Down	PVDD=24V		20	40	uA
I _Q (HV)	Quiescent current for PVDD (50%/50% PWM duty)	PVDD=24V		15		mA
I _Q (LV)	Quiescent current for DVDD (Un-mute)	DVDD=3.3V, PBTL=Low		31	45	mA
T _{SENSOR}	Junction Temperature for Driver Shutdown			165		°C
	Temperature Hysteresis for Recovery from Shutdown			35		°C
UV _{DVDDH}	DVDD Under Voltage Release			2.99		V
UV _{DVDDL}	DVDD Under Voltage Active			2.89		V
UV _{PVDDH}	VDDL/R Under Voltage Release			7.7		V
UV _{PVDDL}	VDDL/R Under Voltage Active			7.1		V
OV _H	VDDL/R Over Voltage Active			29.2		V
OV _L	VDDL/R Under Voltage Release			28.5		V
R _{DS(on)}	Static Drain-to-Source On-state Resistor, NMOS	PVDD=24V, I _d =500mA		180		mΩ
I _{SC}	L(R) Channel Over-Current Protection (Note 2)	PVDD=24V		9		A
		PVDD=12V		8.5		A
	Mono Over-Current Protection (Note 2)	PVDD=24V		18		A
		PVDD=12V		17		A
V _{IH}	High-Level Input Voltage	DVDD=3.3V	2.0			V
V _{IL}	Low-Level Input Voltage	DVDD=3.3V			0.8	V
V _{OH}	High-Level Output Voltage	DVDD=3.3V	2.4			V
V _{OL}	Low-Level Output Voltage	DVDD=3.3V			0.4	V
C _I	Input Capacitance			6.4		pF

Note 2: Loudspeaker over-current protection is only effective when loudspeaker drivers are properly connected with external LC filters. Please refer to the application circuit example for recommended LC filter configuration.

Application Circuit Example for Stereo

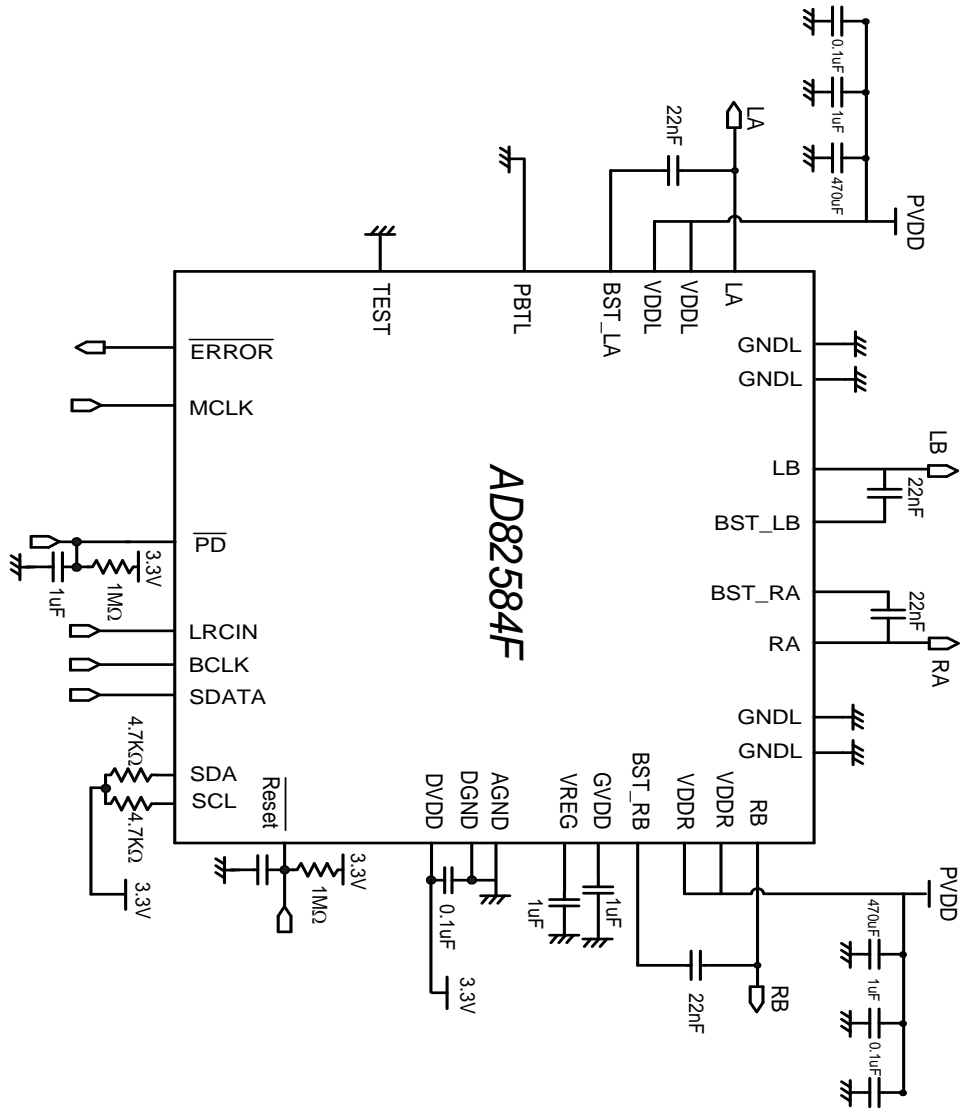

Pin	Logic	0	1
PD	Power Down	0	Normal
Reset	Reset	Reset	Normal
PBTTL		Stereo	Mono

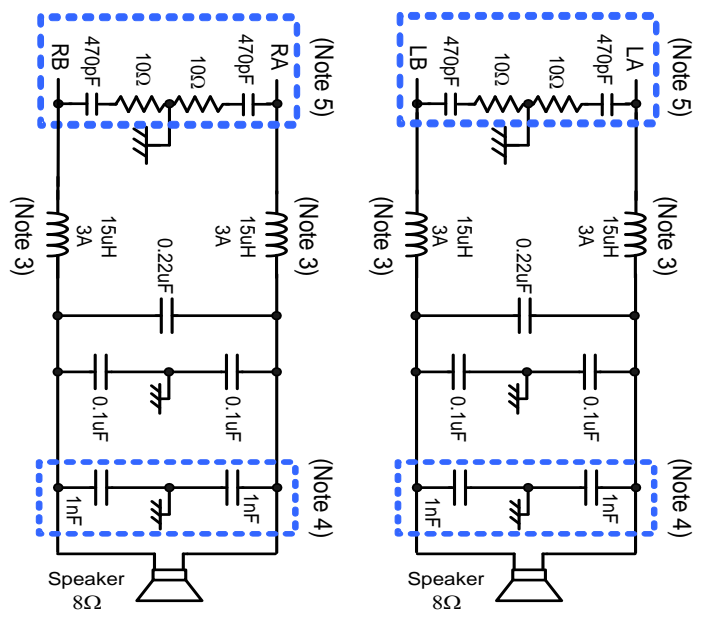

- Note 3: When concerning about short-circuit protection or performance, it is suggested using the choke with its I_{pc} larger than I_{sc} .
- Note 4: These capacitors should be placed as close to speaker jack as possible, and their values should be determined according to EMI test results.
- Note 5: The snubber circuit is used to suppress overshoot voltage on output pin, and it is also helpful with EMI suppression.

Application Circuit Example for Mono

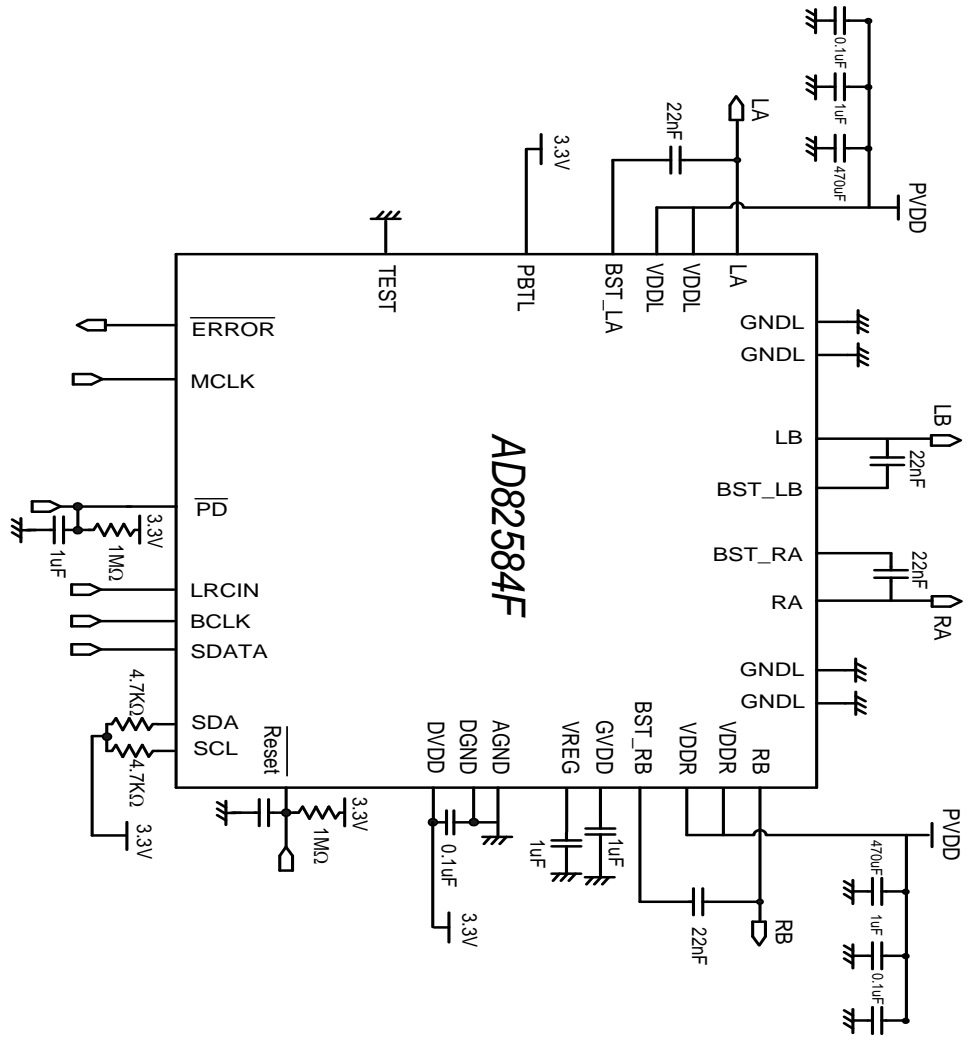

Pin	Logic	0	1
PD	Power Down	Normal	Normal
Reset	Reset	Reset	Mono
PBTTL	Stereo		

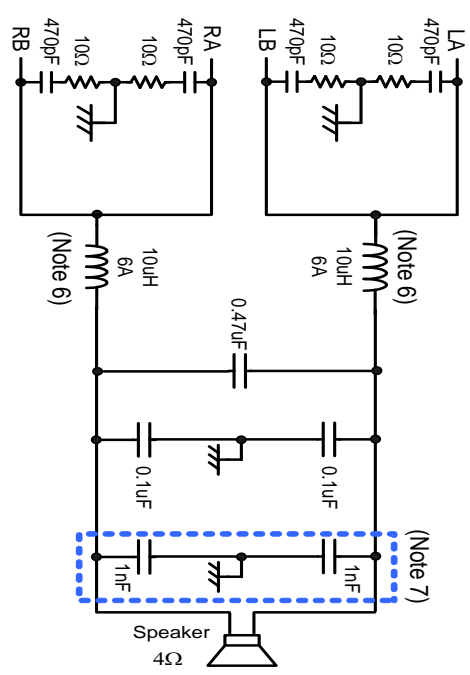

Note 6: When concerning about short-circuit protection or performance, it is suggested using the choke with its I_{pc} larger than I_{sc} .

Note 7: These capacitors should be placed as close to speaker jack as possible, and their values should be determined according to EMI test results.

Electrical Characteristics and Specifications for Loudspeaker

● **BTL (Bridge-Tied-Load) output for Stereo**

Condition: $T_A=25^{\circ}\text{C}$, $DVDD=3.3\text{V}$, $VDDL=VDDR=24\text{V}$, $F_S=48\text{kHz}$, Load= 8Ω with passive LC lowpass filter ($L=15\mu\text{H}$ with $R_{DC}=63\text{m}\Omega$, $C=220\text{nF}$); Input is 1kHz sinewave. Volume is 0dB unless otherwise specified.

Symbol	Parameter	Condition	Input Level	Min	Typ	Max	Units
P_O (Note 9)	RMS Output Power (THD+N=0.15%)				25		W
	RMS Output Power (THD+N=0.10%)				15		W
	RMS Output Power (THD+N=0.08%)				10		W
THD+N	Total Harmonic Distortion + Noise	$P_O=7.5\text{W}$			0.07		%
SNR	Signal to Noise Ratio (Note 8)	Maximum power at THD < 1% @ 1kHz			106		dB
DR	Dynamic Range (Note 8)		-60dB		108		dB
V_n	Output Noise (Note 8)	20Hz to 20kHz			100		μV
PSRR	Power Supply Rejection Ratio	$V_{\text{RIPPLE}}=1\text{V}_{\text{RMS}}$ at 1kHz			-73		dB
	Channel Separation	1W @ 1kHz			-72		dB

Note 8: Measured with A-weighting filter.

Note 9: Thermal dissipation is limited by package type and PCB design. The external heat-sink or system cooling method should be adopted for maximum power output.

Total Harmonic Distortion + Noise vs. Output Power (BTL)

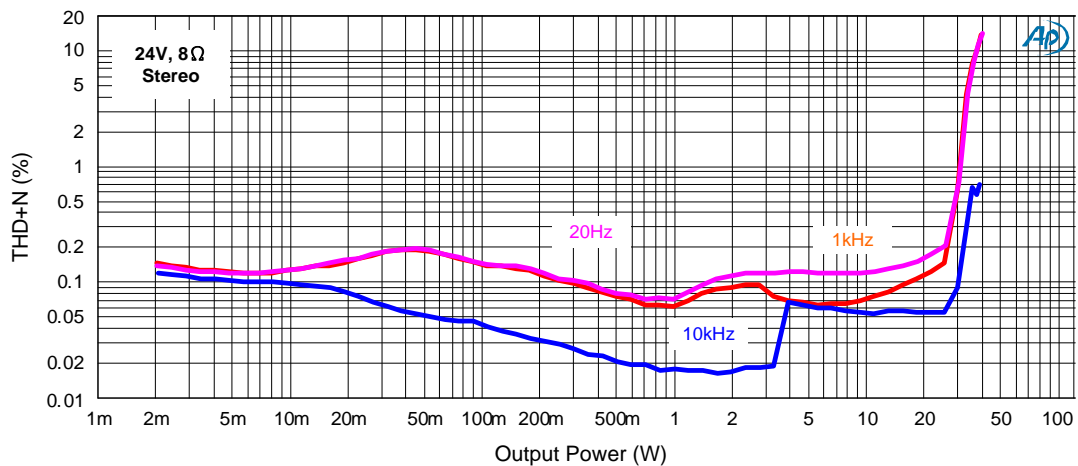

Total Harmonic Distortion + Noise vs. Output Power (BTL)

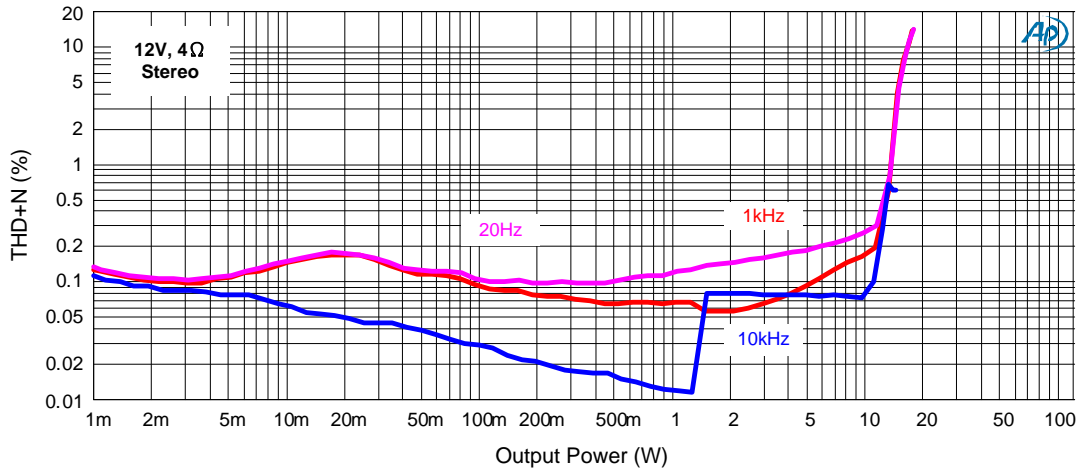

Total Harmonic Distortion + Noise vs. Output Power (BTL)

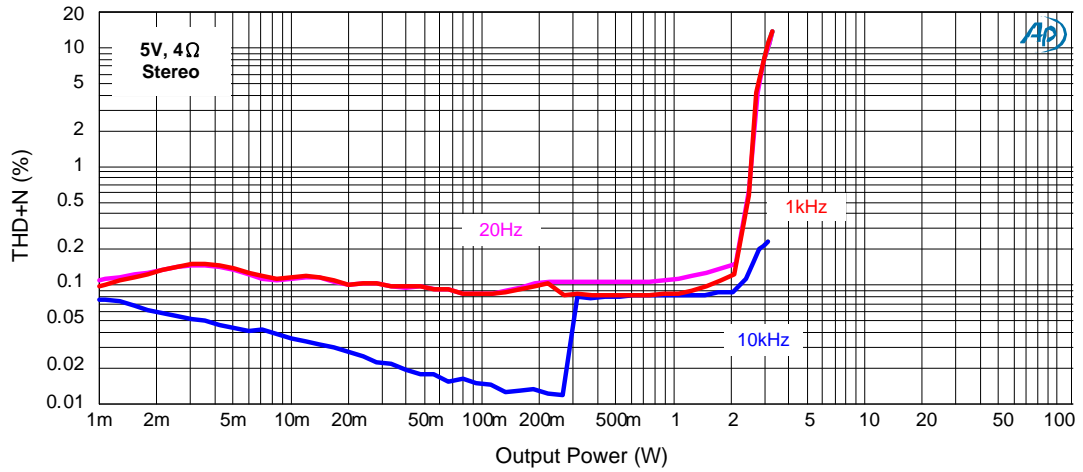

Total Harmonic Distortion + Noise vs. Frequency (BTL)

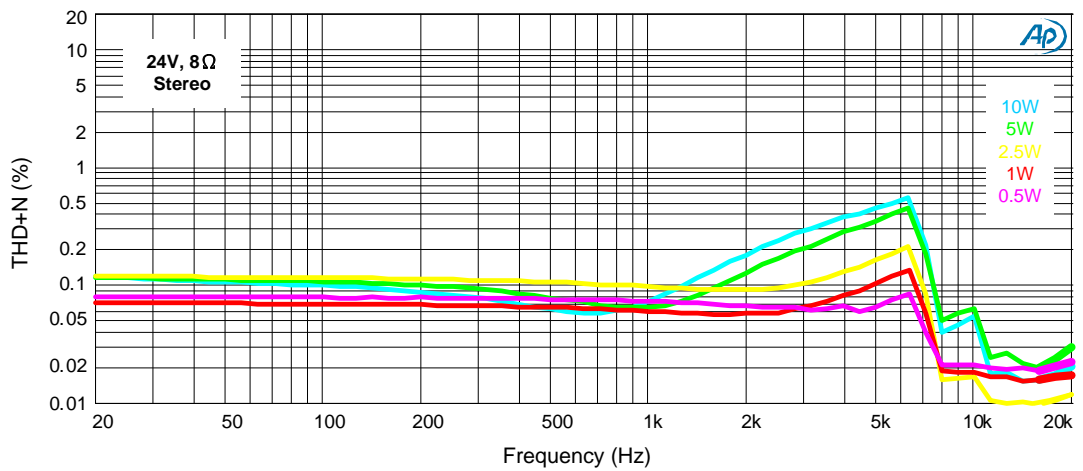

Total Harmonic Distortion + Noise vs. Frequency (BTL)

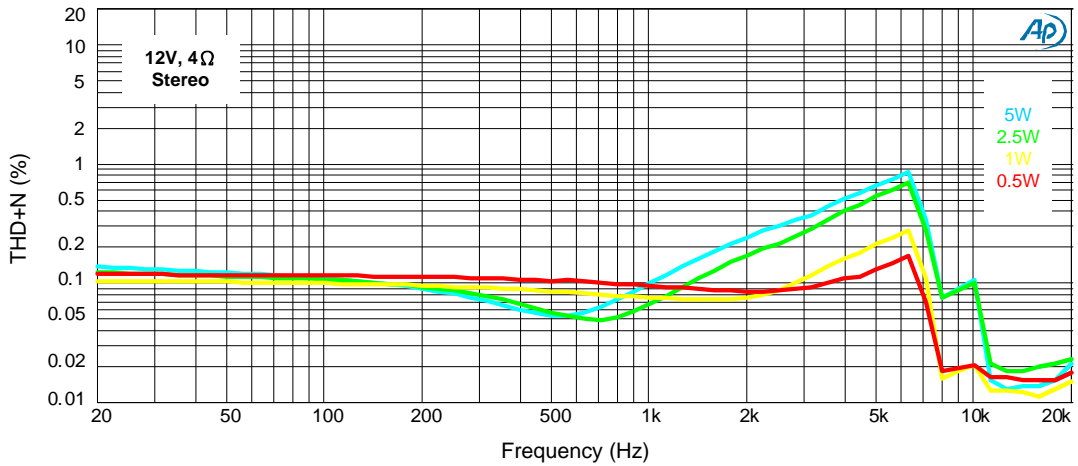

Total Harmonic Distortion + Noise vs. Frequency (BTL)

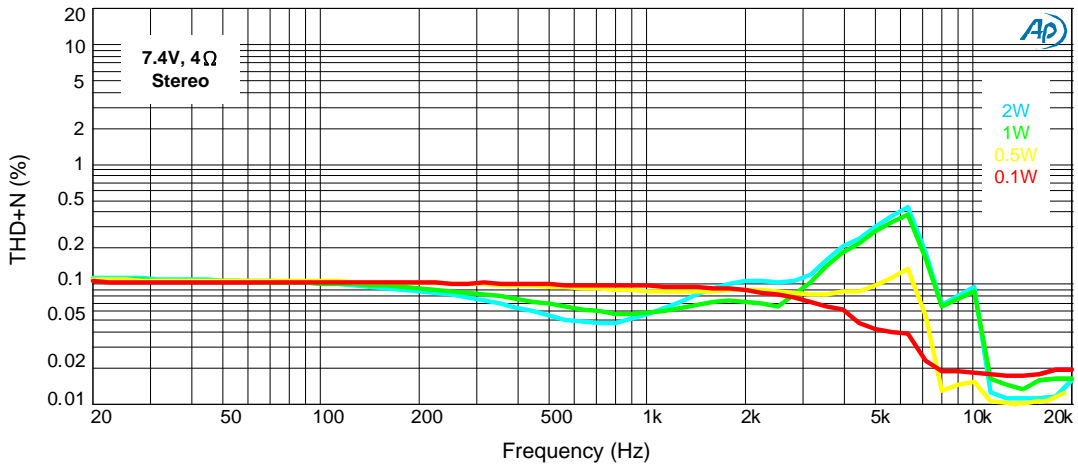

Total Harmonic Distortion + Noise vs. Frequency (BTL)

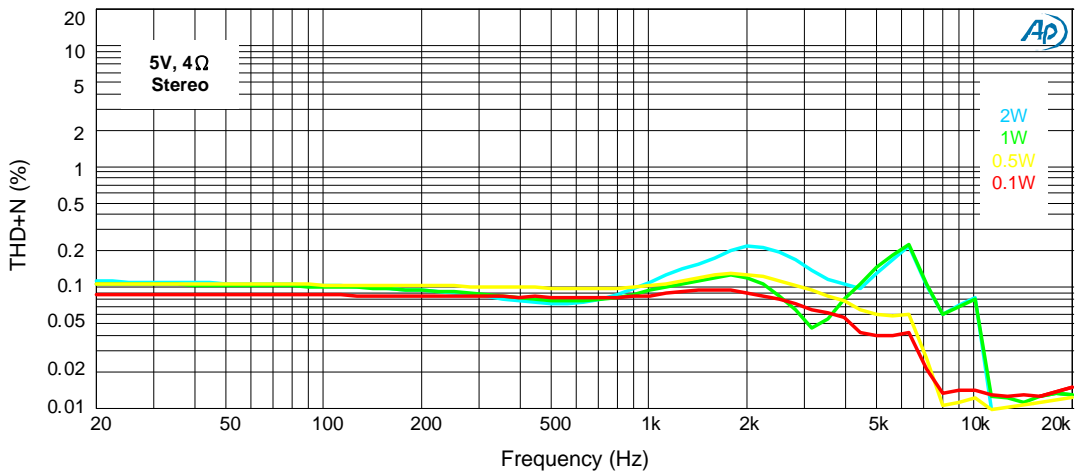

Cross-talk (Stereo, BTL)

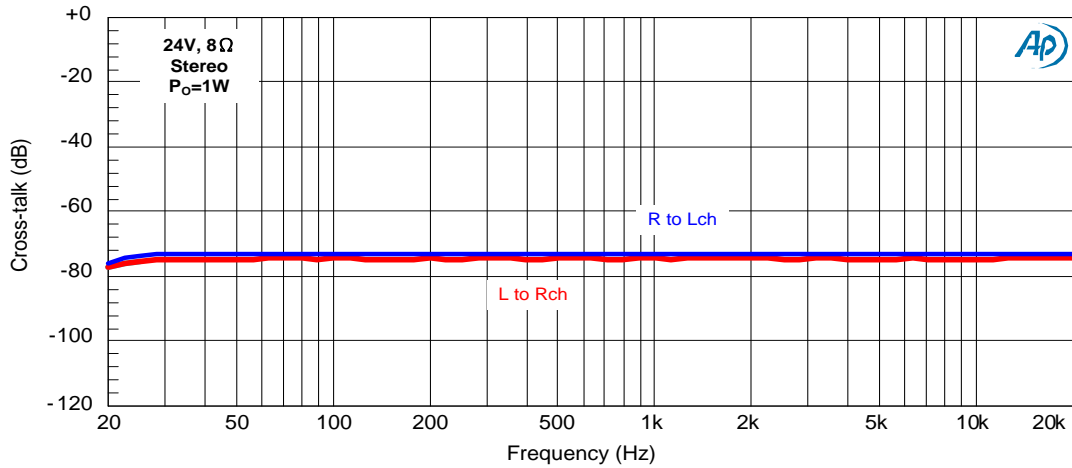

Frequency Response (BTL)

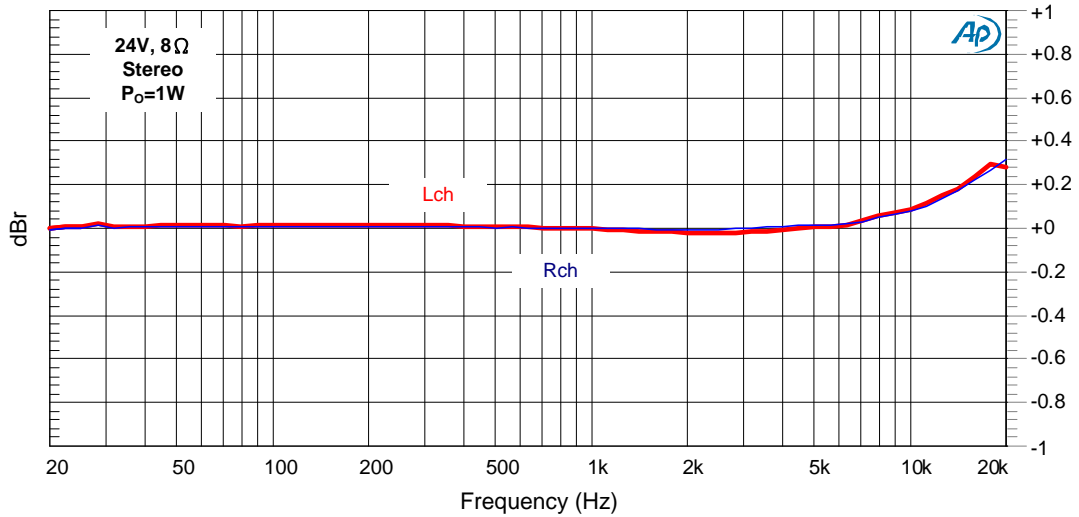

Output Power vs. Supply Voltage (BTL, 8ohm)

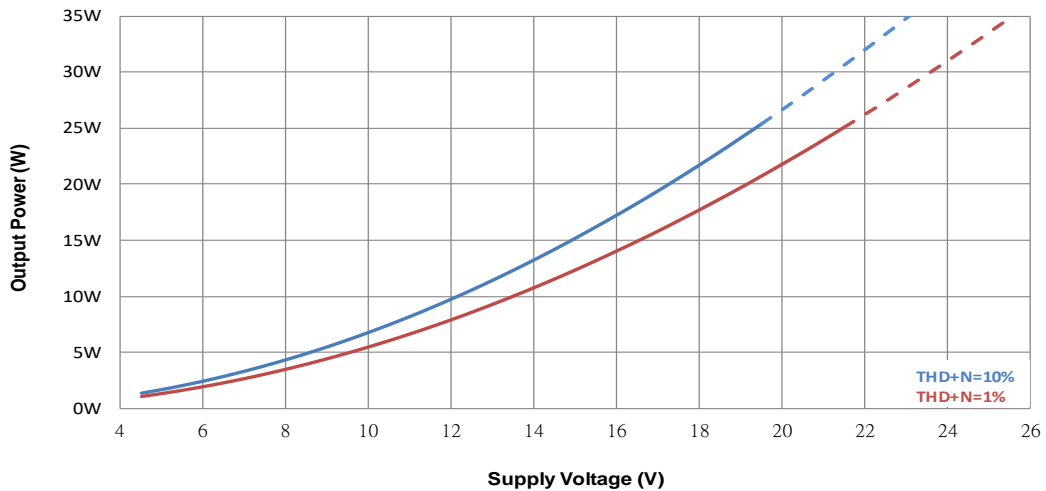

Note: Dashed Line represent thermally limited regions.

Output Power vs. Supply Voltage (BTL, 6ohm)

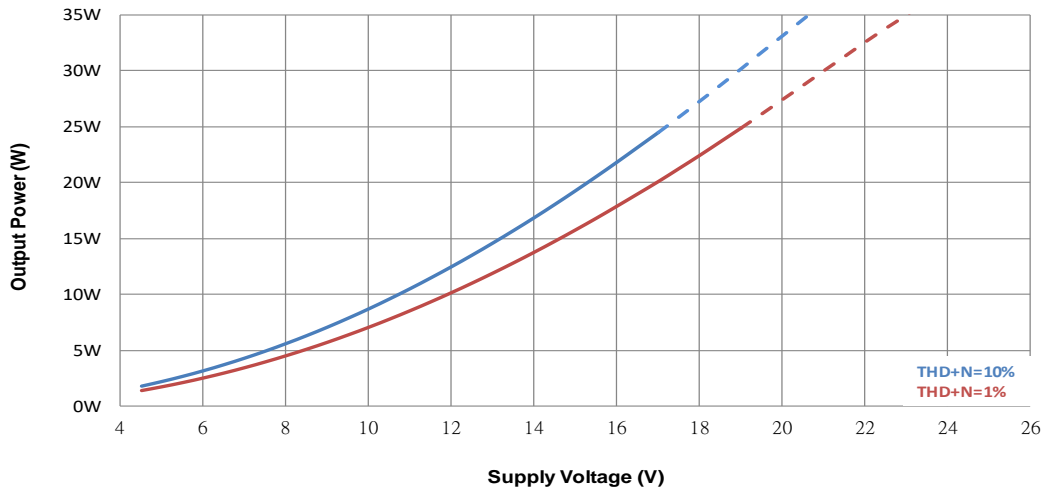

Note: Dashed Line represent thermally limited regions.

Output Power vs. Supply Voltage (BTL, 4ohm)

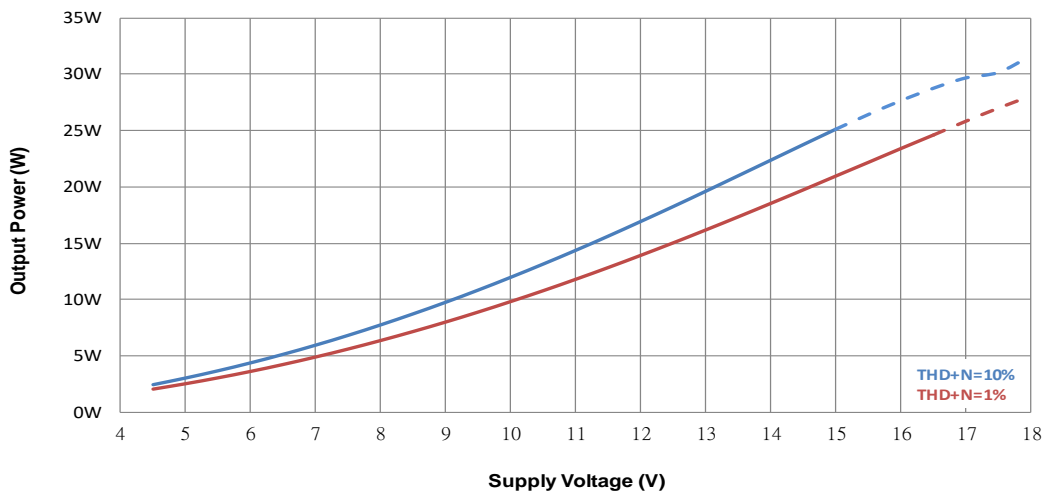

Note: Dashed Line represent thermally limited regions.

Efficiency (Stereo, BTL) during Power Saving Mode

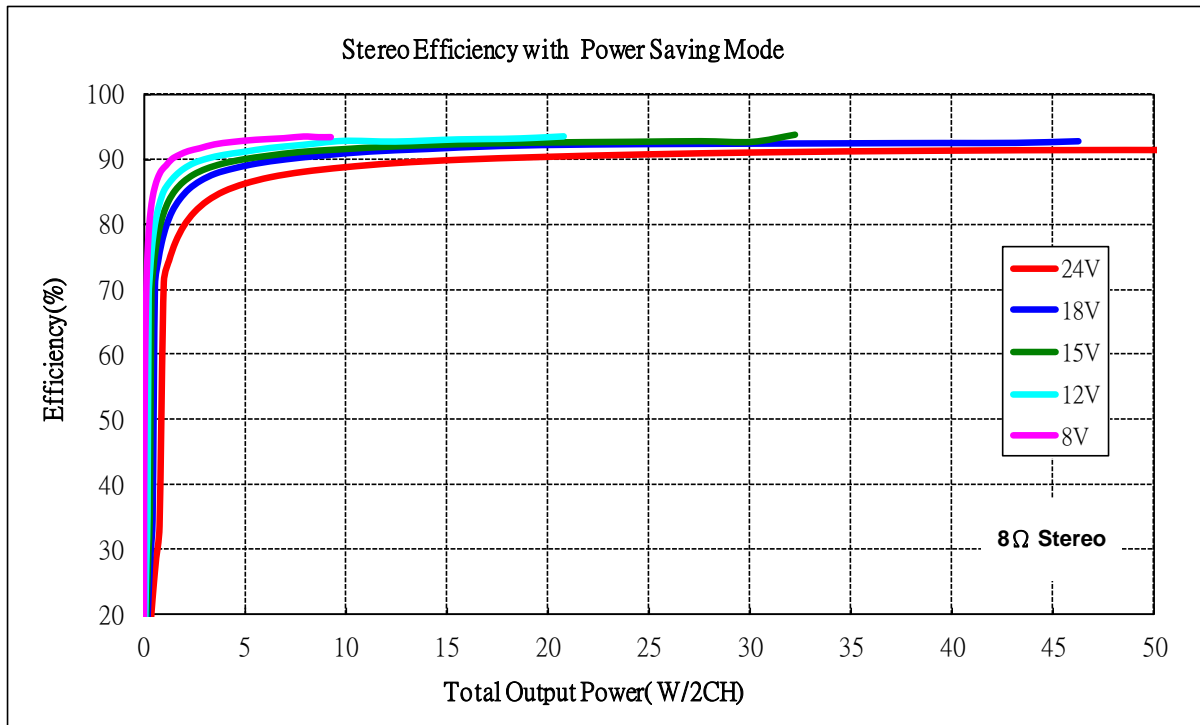

Efficiency (Stereo, BTL) without Power Saving Mode

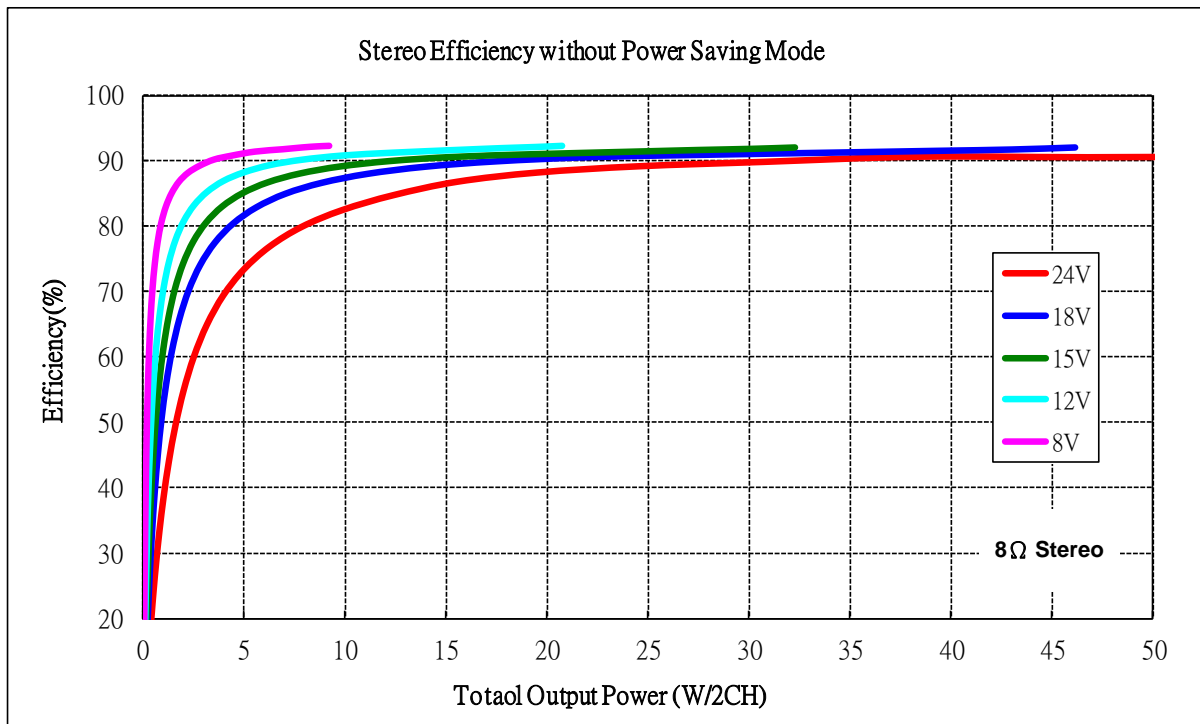

Efficiency (Stereo, BTL) during Power Saving Mode

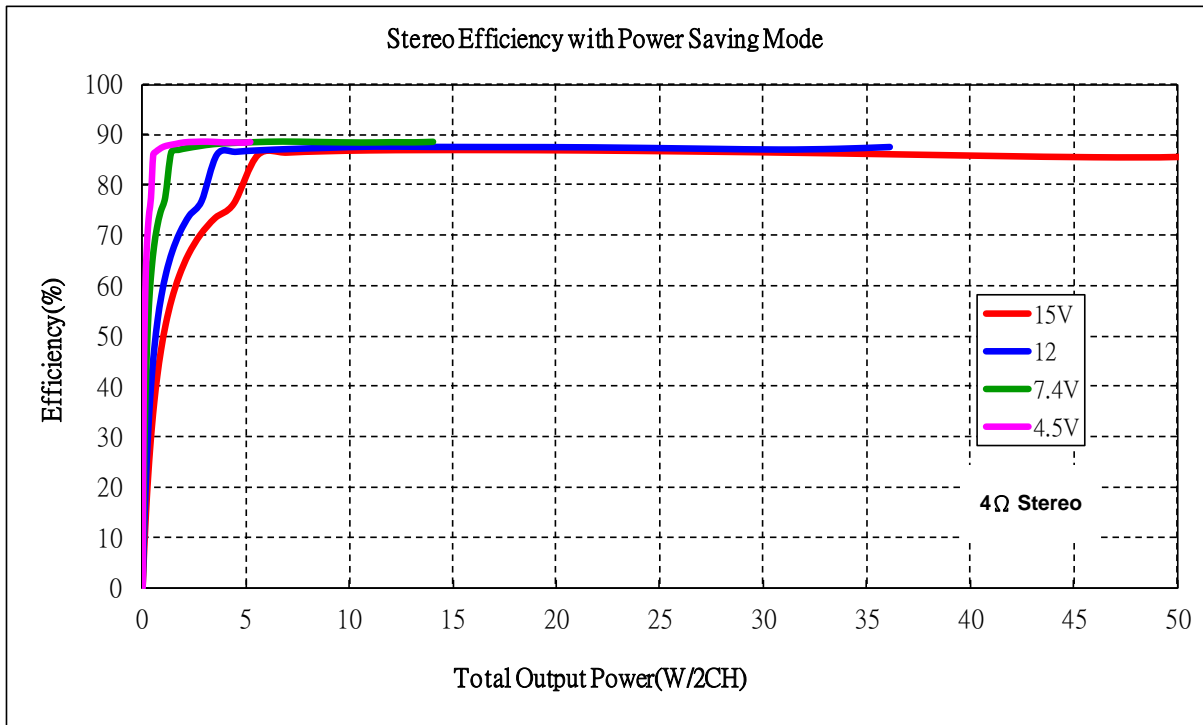

Efficiency (Stereo, BTL) without Power Saving Mode

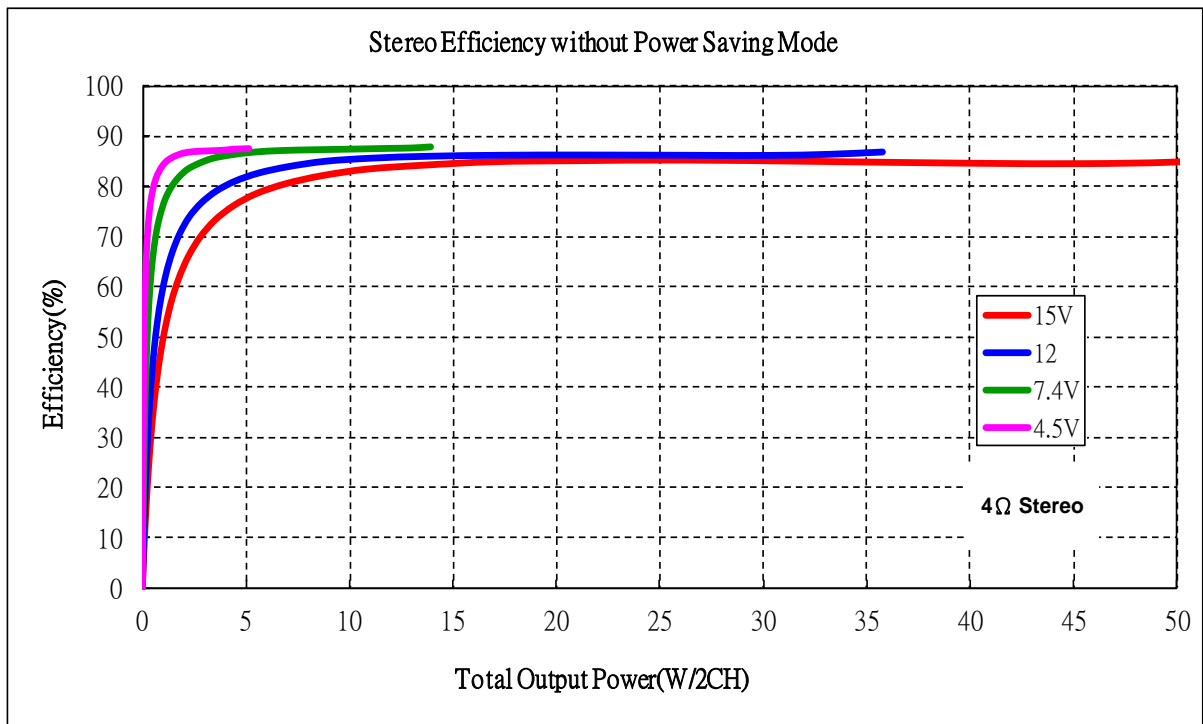

Electrical Characteristics and Specifications for Loudspeaker (cont.)

● **PBTL (Parallel-Bridge-Tied-Load) output for Mono**

Condition: $T_A=25^{\circ}\text{C}$, $DVDD=3.3\text{V}$, $VDDL=VDDR=24\text{V}$, $F_S=48\text{kHz}$, Load= 4Ω with passive LC lowpass filter ($L=10\mu\text{H}$ with $R_{DC}=27\text{m}\Omega$, $C=470\text{nF}$); Input is 1kHz sinewave.

Symbol	Parameter	Condition	Input Level	Min	Typ	Max	Units
P_o (Note 9)	RMS Output Power (THD+N=0.4%)				50		W
	RMS Output Power (THD+N=0.31%)				30		W
	RMS Output Power (THD+N=0.26%)				20		W
THD+N	Total Harmonic Distortion + Noise	$P_o=15\text{W}$			0.22		%
SNR	Signal to Noise Ratio (Note 8)	Maximum power at THD < 1% @1kHz			102		dB
DR	Dynamic Range (Note 8)		-60dB		106		dB
V_n	Output Noise (Note 8)	20Hz to 20kHz			130		μV
PSRR	Power Supply Rejection Ratio	$V_{\text{RIPPLE}}=1V_{\text{RMS}}$ at 1kHz			-78		dB

Note 8: Measured with A-weighting filter.

Note 9: Thermal dissipation is limited by package type and PCB design. The external heat-sink or system cooling method should be adopted for maximum power output.

Total Harmonic Distortion + Noise vs. Output Power (PBTL)

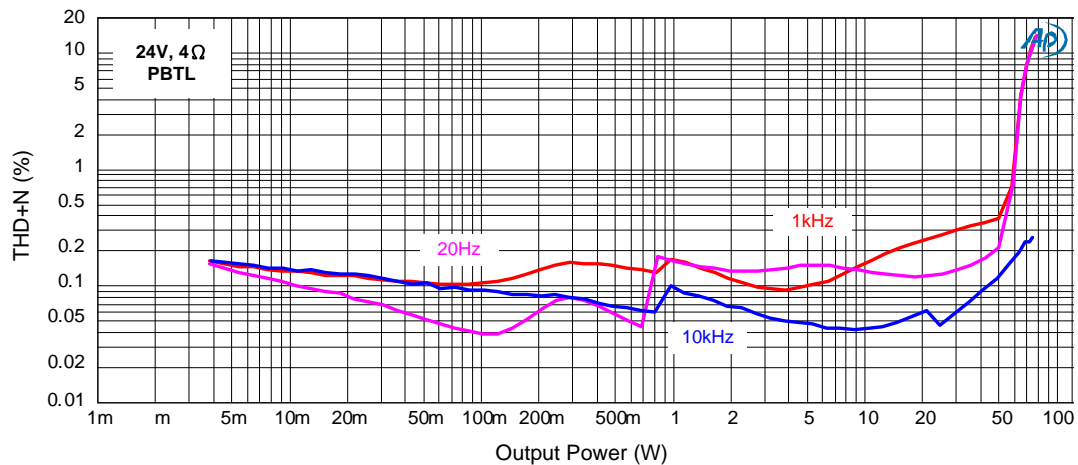

Total Harmonic Distortion + Noise vs. Output Power (PBTL)

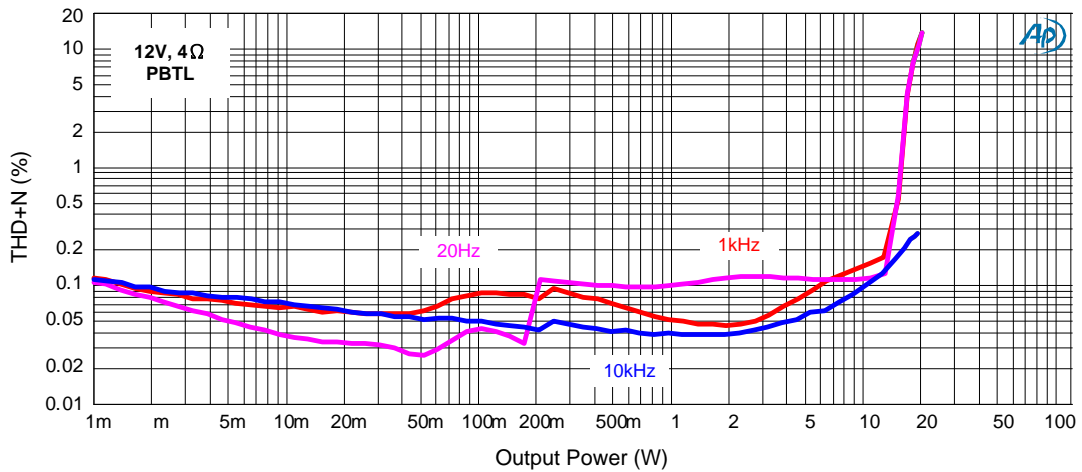

Total Harmonic Distortion + Noise vs. Frequency (PBTL)

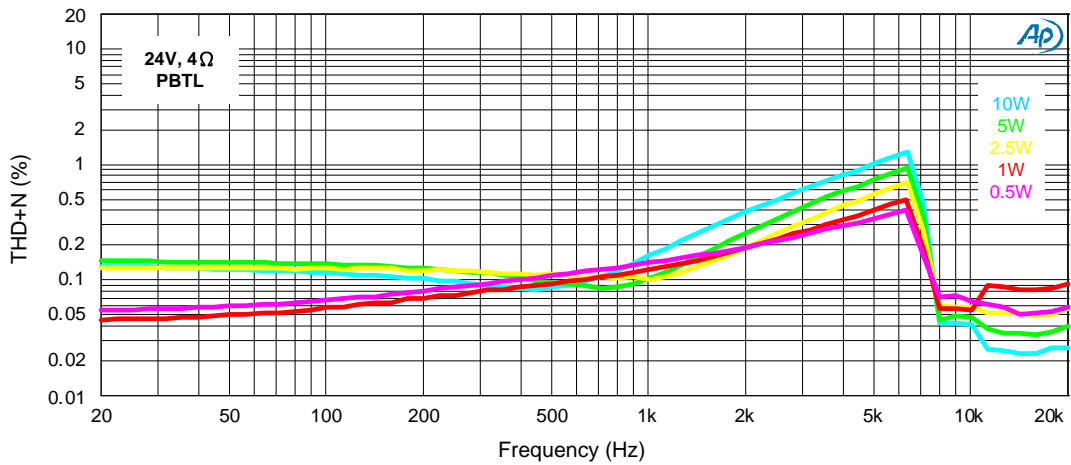

Frequency Response (PBTL)

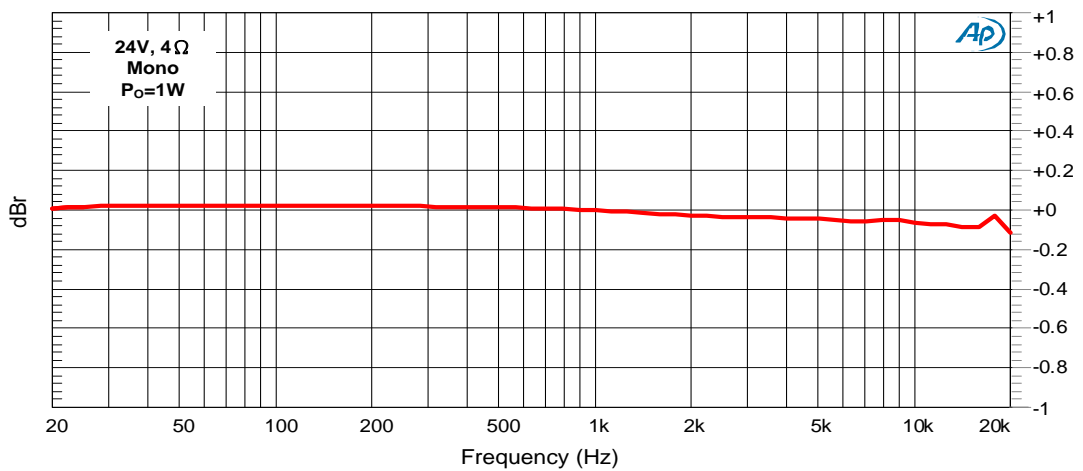

Output Power vs. Supply Voltage (PBTL, 8ohm)

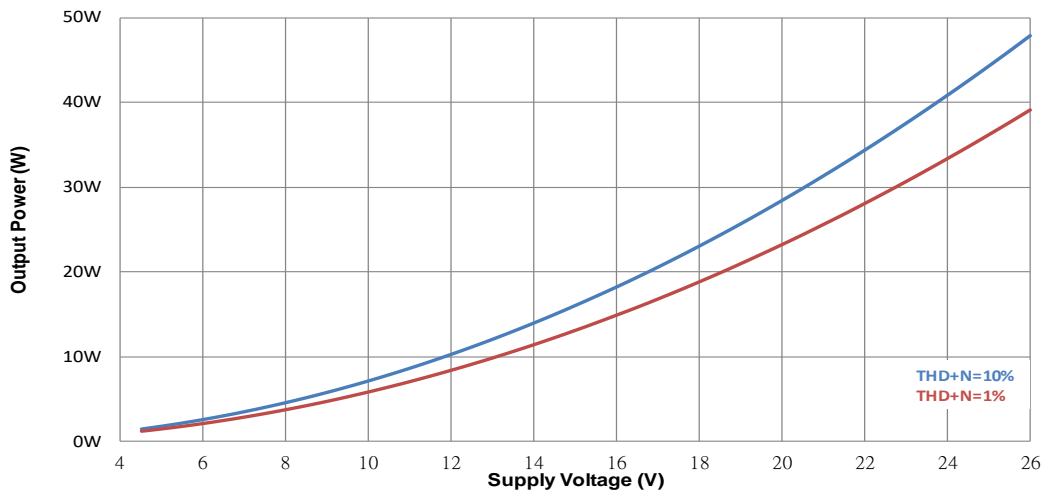

Output Power vs. Supply Voltage (PBTL, 6ohm)

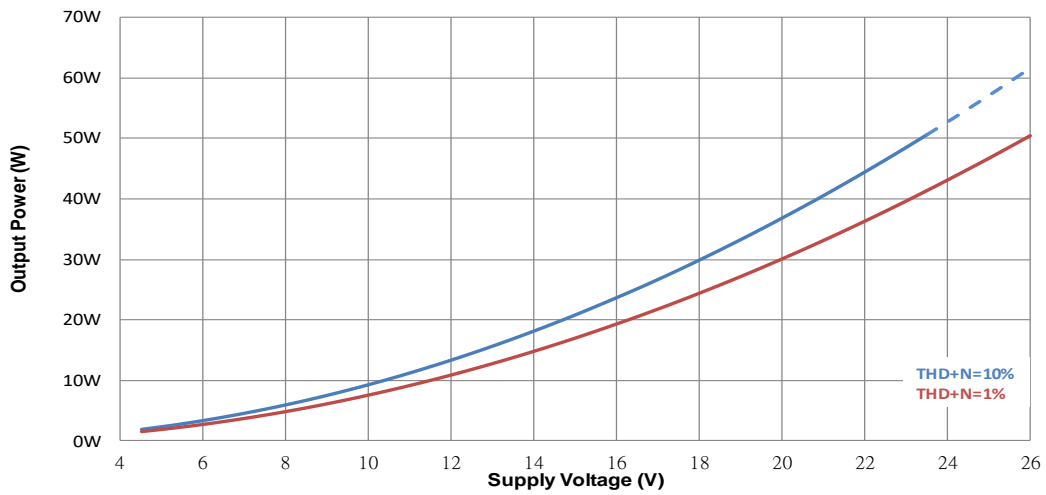

Note: Dashed Line represent thermally limited regions.

Output Power vs. Supply Voltage (PBTL, 4ohm)

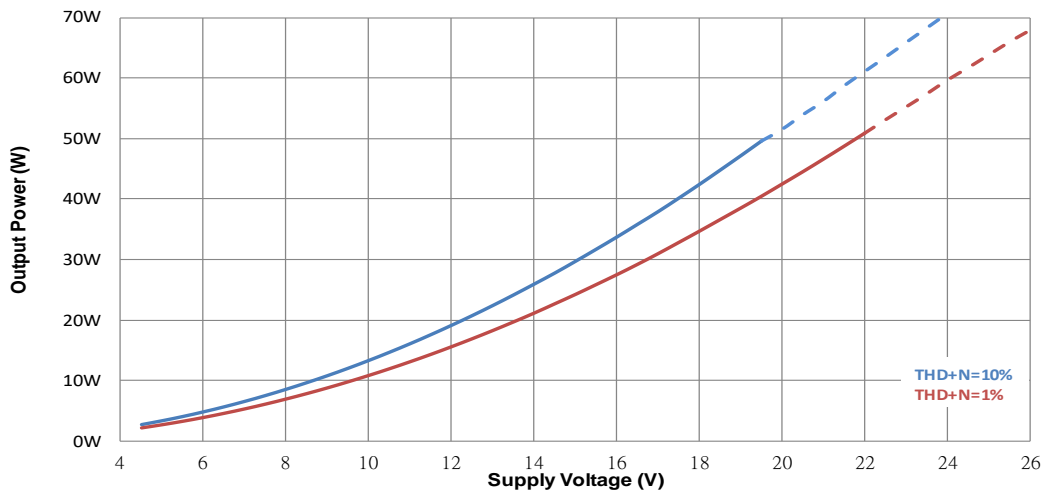

Note: Dashed Line represent thermally limited regions.

Interface configuration

- I²S

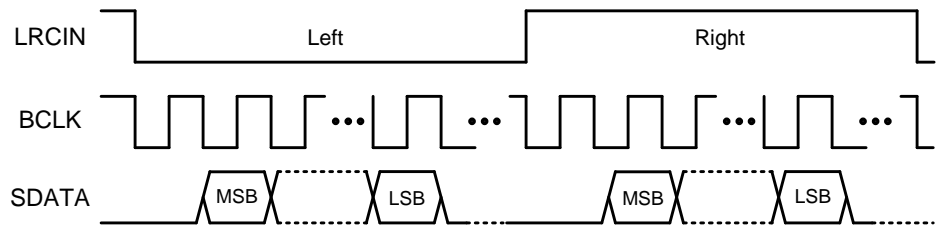

- Left-Alignment

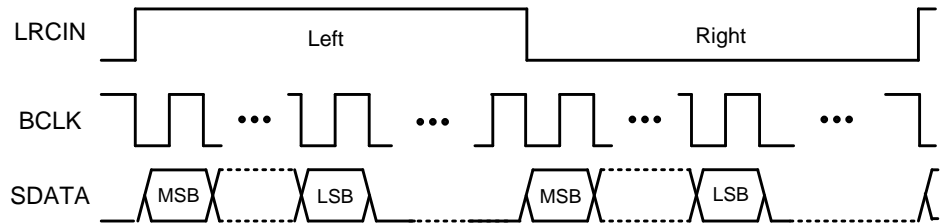

- Right-Alignment

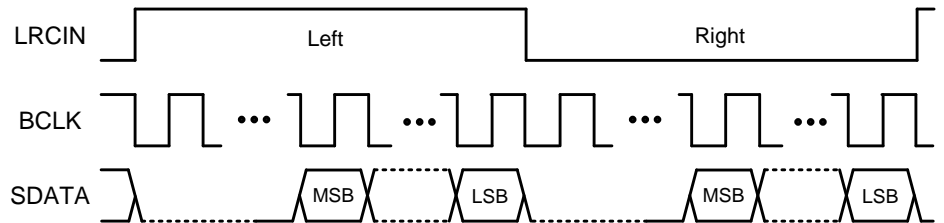

- System Clock Timing

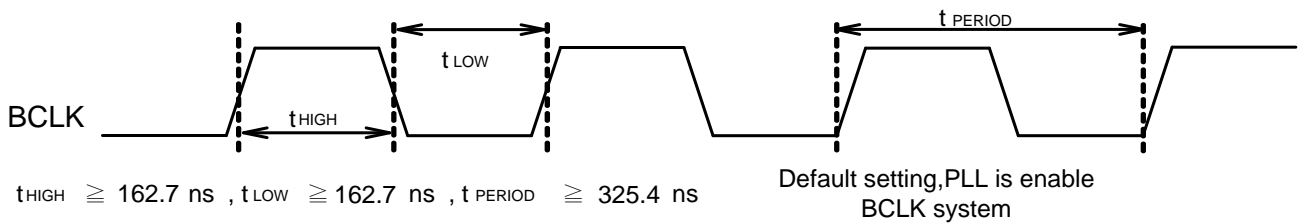

- Timing Relationship (Using I²S format as an example)

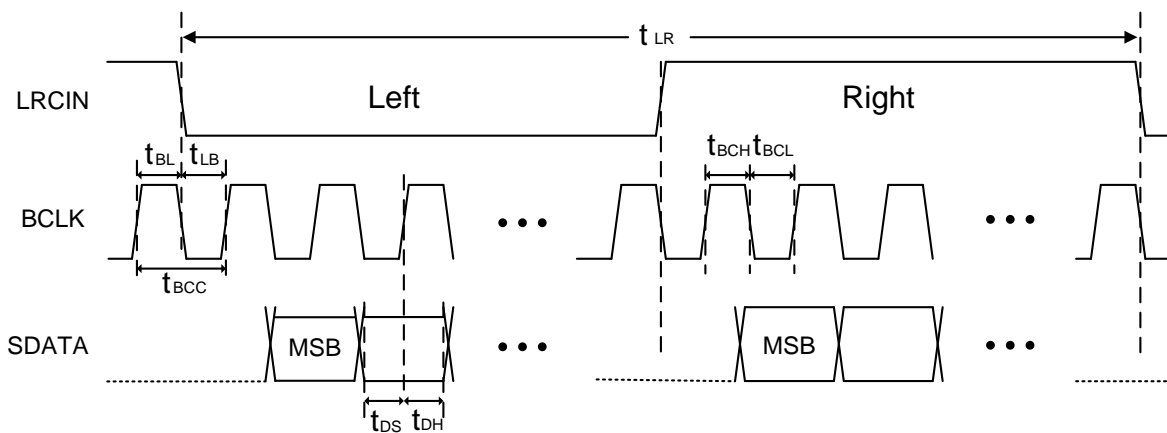

Symbol	Parameter	Min	Typ	Max	Units
--------	-----------	-----	-----	-----	-------

t_{LR}	LRCIN Period ($1/F_s$)	5.2		31.25	μs
t_{BL}	BCLK Rising Edge to LRCIN Edge	25			ns
t_{LB}	LRCIN Edge to BCLK Rising Edge	25			ns
t_{BCC}	BCLK Period ($1/64F_s$)	81.38		488.3	ns
t_{BCH}	BCLK Pulse Width High	40.69		244	ns
t_{BCL}	BCLK Pulse Width Low	40.69		244	ns
t_{DS}	SDATA Set-Up Time	25			ns
t_{DH}	SDATA Hold Time	25			ns

● I²C Timing

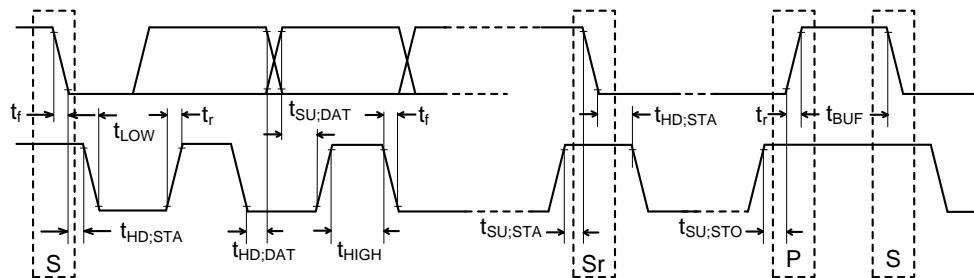

Parameter	Symbol	Standard Mode		Fast Mode		Unit
		MIN.	MAX.	MIN.	MAX.	
SCL clock frequency	f_{SCL}	0	100	0	400	kHz
Hold time for repeated START condition	$t_{HD,STA}$	4.0	---	0.6	---	μs
LOW period of the SCL clock	t_{LOW}	4.7	---	1.3	---	μs
HIGH period of the SCL clock	t_{HIGH}	4.0	---	0.6	---	μs
Setup time for repeated START condition	$t_{SU,STA}$	4.7	---	0.6	---	μs
Hold time for I ² C bus data	$t_{HD,DAT}$	0	3.45	0	0.9	μs
Setup time for I ² C bus data	$t_{SU,DAT}$	250	---	100	---	Ns
Rise time of both SDA and SCL signals	t_r	---	1000	---	300	Ns
Fall time of both SDA and SCL signals	t_f	---	300	---	300	Ns
Setup time for STOP condition	$t_{SU,STO}$	4.0	---	0.6	---	μs
Bus free time between STOP and the next START condition	t_{BUF}	4.7	---	1.3	---	μs
Capacitive load for each bus line	C_b		400		400	pF

Operation Description

The default volume of AD82584F is muted. AD82584F will be activated while the de-mute command via I²C is programmed.

● Internal PLL

AD82584F has a built-in PLL internally, the BCLK/FS or MCLK/FS ratio, which is selected by I²C control interface. The clock inputted into the BCLK or MCLK pin becomes the frequency of multiple edge evaluation in chip internally.

Fs	BCLK/FS Setting Ratio for PLL	BCLK Frequency	Multiple edge evaluation for bit clock	PWM Career Frequency
48kHz	64x	3.072MHz	32x	384kHz
44.1kHz	64x	2.8224MHz	32x	352.8kHz
32kHz	64x	2.048MHz	32x	256kHz

Fs	MCLK/FS Setting Ratio for PLL	MCLK Frequency	Multiple edge evaluation for Master clock	PWM Career Frequency
48kHz	256x	12.288MHz	8x	384kHz
44.1kHz	256x	11.2896MHz	8x	352.8kHz
32kHz	256x	8.192MHz	8x	256kHz
8kHz	256x	2.048MHz	32x	256kHz

● Reset

When the $\overline{\text{RESET}}$ pin is lowered, AD82584F will clear the stored data and reset the register table to default values. AD82584F will exit reset state at the 512th internal clock cycle after the $\overline{\text{RESET}}$ pin is raised to high.

● Power down control

AD82584F has a built-in volume fade-in/fade-out design for PD/Mute function. The relative PD timing diagrams for loudspeakers are shown below.

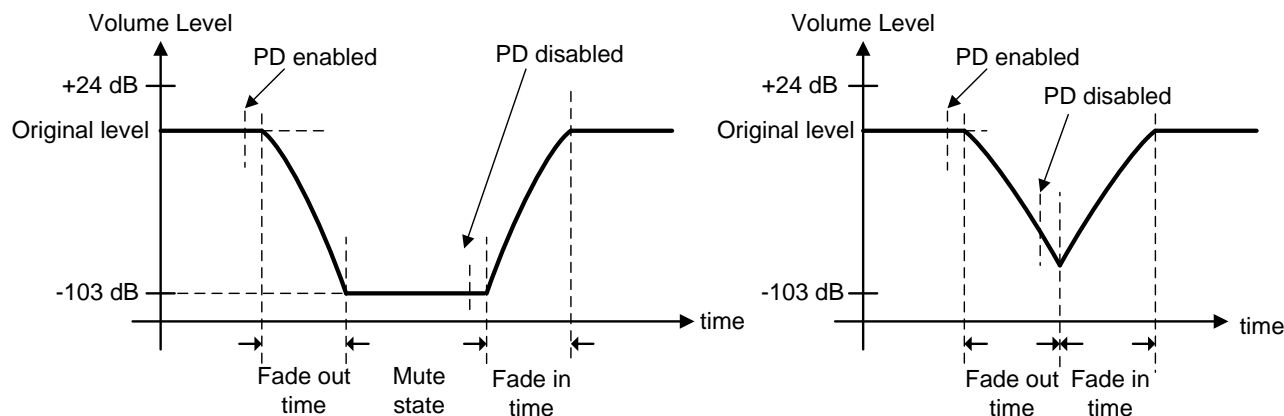

$$\left(10^{\frac{target(dB)}{20}} - 10^{\frac{original(dB)}{20}}\right) \times 128 \times (1/96K)$$

(Note: Address 0x1C B[2] = 0)

The volume level will be decreased to $-\infty$ dB in several LRCIN cycles. Once the fade-out procedure is finished, AD82584F will turn off the power stages, clock signals (for digital circuits) and current (for analog circuits). After PD pin is pulled low, AD82584F requires T_{fade} to finish the forementioned work before entering power down state. User can not program AD82584F during power down state. Also, all settings in the registers will remain intact unless DVDD is removed.

If the PD signal is removed during the fade-out procedure (above, right figure), AD82584F will still execute the fade-in procedure. In addition, AD82584F will establish the analog circuits' bias current and send the clock signals to digital circuits. Afterwards, AD82584F will return to its normal status.

- Self-protection circuits

AD82584F has built-in protection circuits including thermal, short-circuit, under-voltage detection, and over voltage circuits.

- (i) When the internal junction temperature is higher than 165°C, power stages will be turned off and AD82584F will return to normal operation once the temperature drops to 130°C. The temperature values may vary around 10%.
- (ii) The short-circuit protection circuit protects the output stage when the wires connected to loudspeakers are shorted to each other or GND/VDD. For normal 24V operations, the current flowing through the power stage will be less than 9A for stereo configuration. Otherwise, the short-circuit detectors may pull the $\overline{\text{ERROR}}$ pin to DGND, disabling the output stages. When the over-temperature or short-circuit condition occurs, the open-drain $\overline{\text{ERROR}}$ pin will be pulled low and latched into ERROR state.

Once short-circuit condition is removed, AD82584F will exit ERROR state when one of the following conditions is met: (1) $\overline{\text{RESET}}$ pin is pulled low, (2) $\overline{\text{PD}}$ pin is pulled low, (3) Master mute is enabled through the I²C interface.

- (iii) Once the DVDD voltage is lower than 2.89V, AD82584F will turn off its loudspeaker power stages. When DVDD becomes higher than 2.99V, AD82584F will return to normal operation.
- (iv) Once the PVDD voltage is higher than 29.2V, AD82584F will turn off its loudspeaker power stages. When PVDD becomes lower than 28.5V, AD82584F will return to normal operation.
- (v) Once the PVDD voltage is lower than 7.1V, AD82584F will turn off its loudspeaker power stages. When PVDD becomes higher than 7.7V, AD82584F will return to normal operation.

- Anti-pop design

AD82584F will generate appropriate control signals to suppress pop sounds during initial power on/off, power down/up, mute, and volume level changes.

- 3D surround sound

AD82584F provides the virtual surround sound technology with greater separation and depth voice quality for stereo signals.

- I²C Chip Select

$\overline{\text{ERROR}}$ is an input pin during power. It can be pulled High (15-kΩ pull up) or Low (15-kΩ pull down). Low indicates an I²C address of 0x30, and high an address of 0x31.

● Output configuration

The PBTL pin defines the configuration mode. AD82584F can be configured to stereo or mono via PBTL pin.

Table 1.

PBTL	Configuration Mode
0	Stereo
1	Mono
X	Mono via I ² C control (MONO_EN=1 and MONO_KEY=3006(HEX))

Configuration figures:

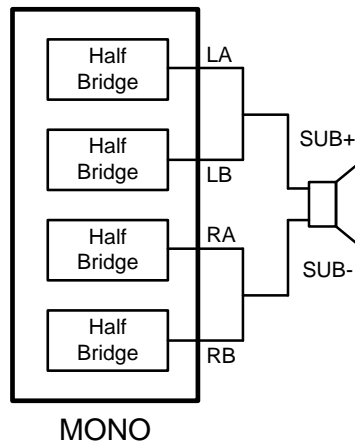
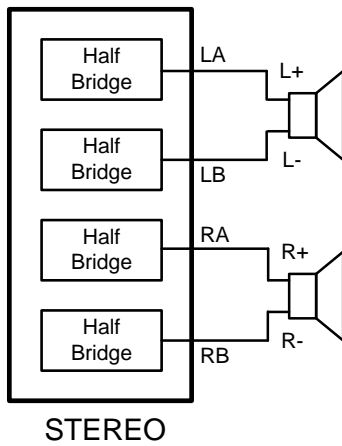

● Power on sequence

Hereunder is AD82584F's power on sequence. Give a de-mute command via I²C when the whole system is stable.

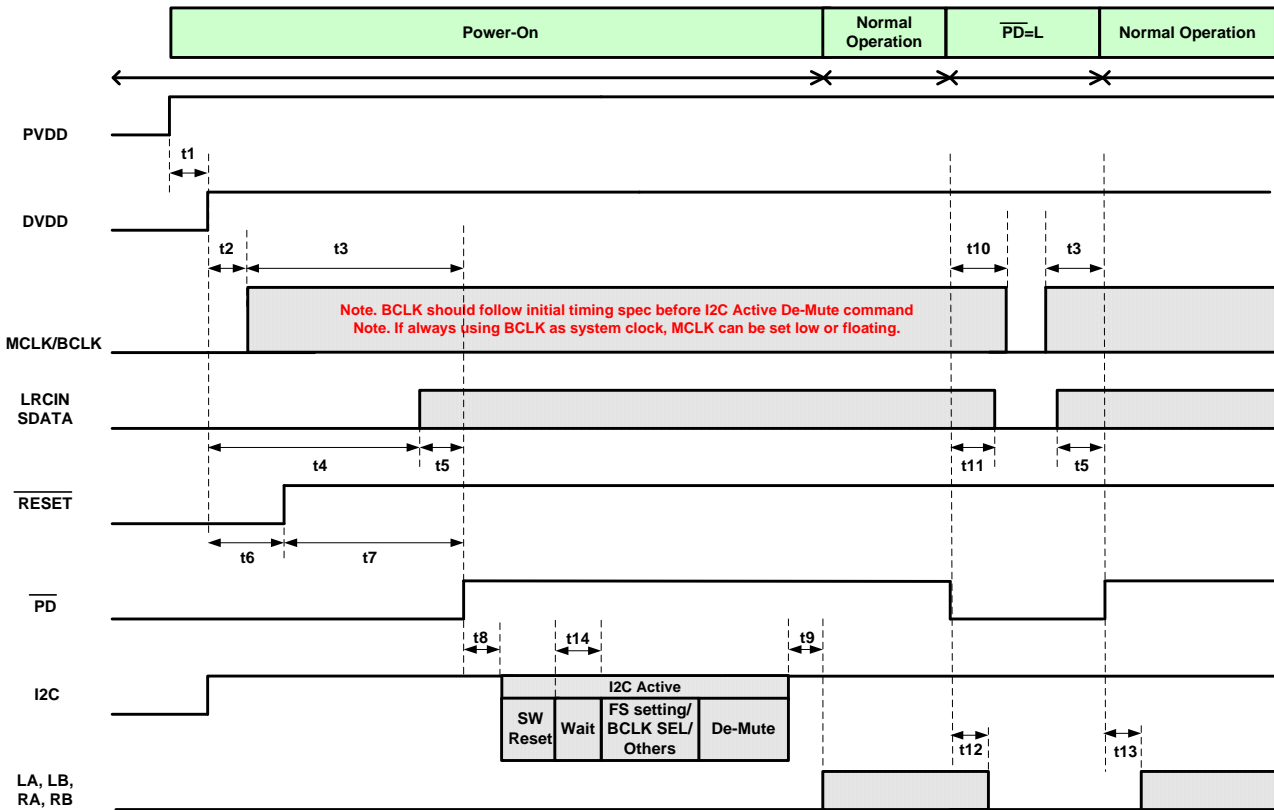

Note:

Please be noted below sequence shall be follow up with “I2C Active” processing,

- (1) Set S/W reset bit = 0 → (2) Delay 5ms → (3) Set S/W reset bit = 1 → (4) Delay 20ms → (5) Set all channels = mute (setting address 0X02 = 0X7F) → (6) Set sampling frequency and other registers (except setting address 0X02) → (7) Set all channels = de-mute (setting address 0X02 = 0X00)

Symbol	Condition	Min	Max	Units
t1		0	-	msec
t2		0	-	msec
t3		10	-	msec
t4		0	-	msec
t5		10	-	msec
t6		10	-	msec
t7		0	-	msec
t8		20	-	msec
t9		-	0.1	msec
t10		25	-	msec

t11		25	-	msec
t12		-	22(FADE_SPEED=0) 176(FADE_SPEED=1)	msec
t13		-	20	msec
t14		20		msec

● Power off sequence

Hereunder is AD82584F's power off sequence.

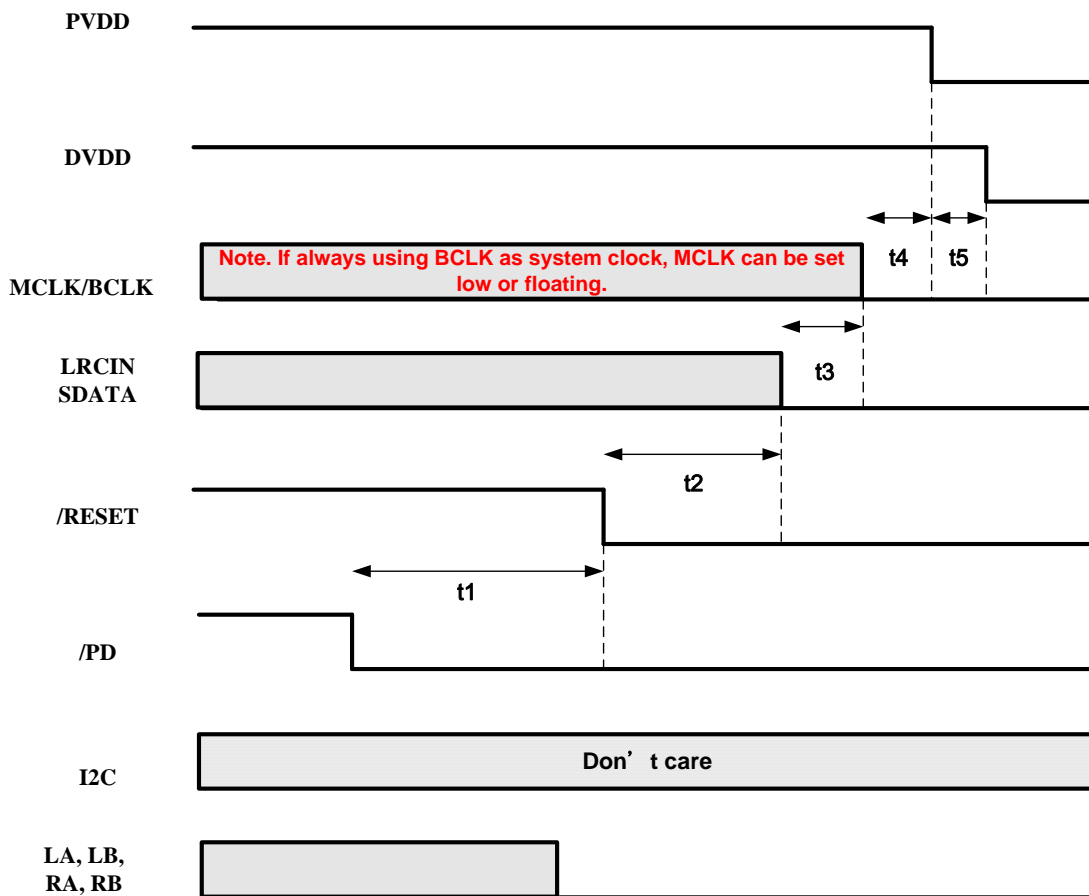

Symbol	Condition	Min	Max	Units
t1		35(FADE_SPEED=0) 280(FADE_SPEED=1)	-	msec
t2		0.1	-	msec
t3		0	-	msec
t4		1	-	msec
t5		1	-	msec

I²C-Bus Transfer Protocol

● Introduction

AD82584F employs I²C-bus transfer protocol. Two wires, serial data and serial clock carry information between the devices connected to the bus. Each device is recognized by a unique 7-bit address and can operate as either a transmitter or a receiver. The master device initiates a data transfer and provides the serial clock on the bus. AD82584F is always an I²C slave device.

● Protocol

■ START and STOP condition

START is identified by a high to low transition of the SDA signal. A START condition must precede any command for data transfer. A STOP is identified by a low to high transition of the SDA signal. A STOP condition terminates communication between AD82584F and the master device on the bus. In both START and STOP, the SCL is stable in the high state.

■ Data validity

The SDA signal must be stable during the high period of the clock. The high or low change of SDA only occurs when SCL signal is low. AD82584F samples the SDA signal at the rising edge of SCL signal.

■ Device addressing

The master generates 7-bit address to recognize slave devices. When AD82584F receives 7-bit address matched with 0110000 or 0110001 ($\overline{\text{ERROR}}$ pin state during power up), AD82584F will acknowledge at the 9th bit (the 8th bit is for R/W bit). The bytes following the device identification address are for AD82584F internal sub-addresses.

■ Data transferring

Each byte of SDA signaling must consist of 8 consecutive bits, and the byte is followed by an acknowledge bit. Data is transferred with MSB first, as shown in the figure below. In both write and read operations, AD82584F supports both single-byte and multi-byte transfers. Refer to the figure below for detailed data-transferring protocol.

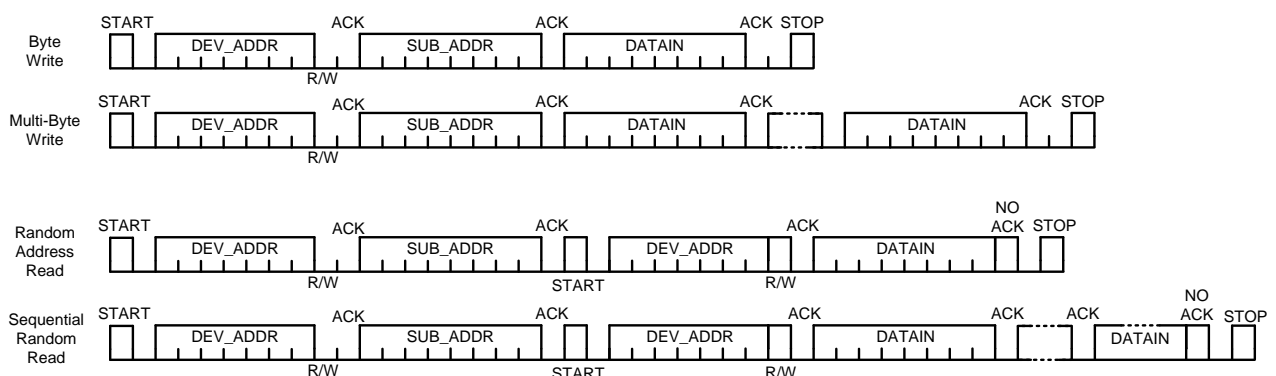

Register Table

The AD82584F’s audio signal processing data flow is shown below. User can control these functions by programming appropriate settings in the register table. In this section, the register table is summarized first. The definition of each register follows in the next section.

One band DRC

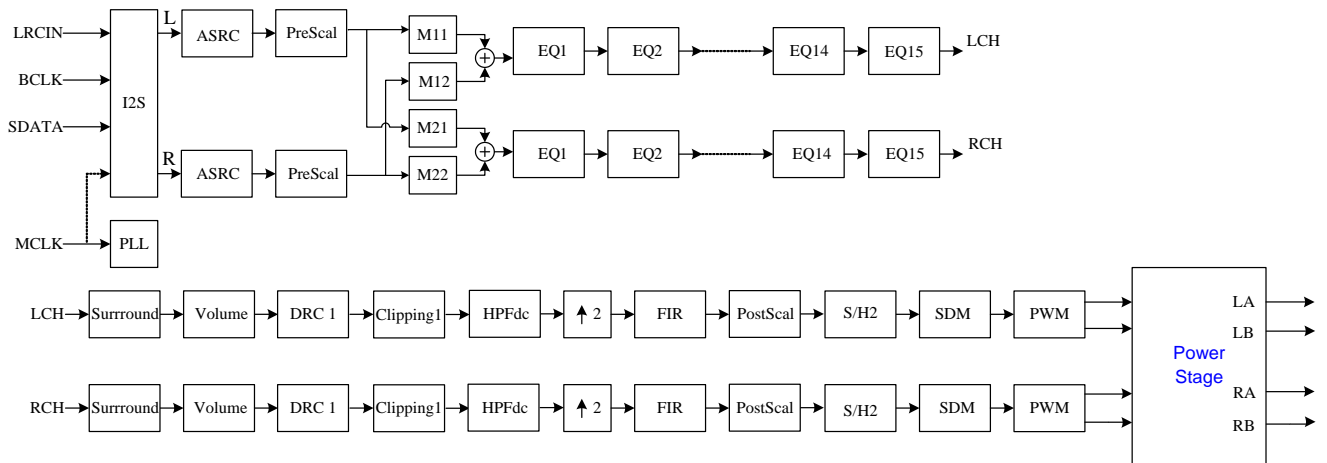

Dual band DRC

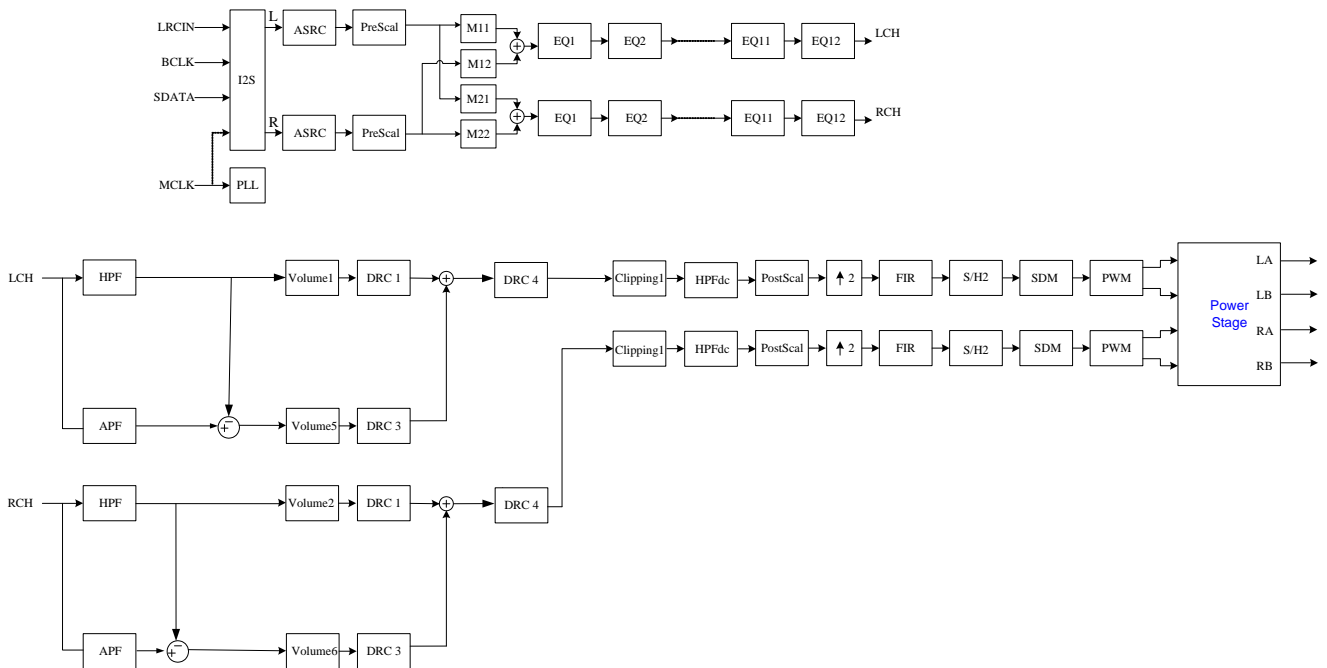

Three bands DRC

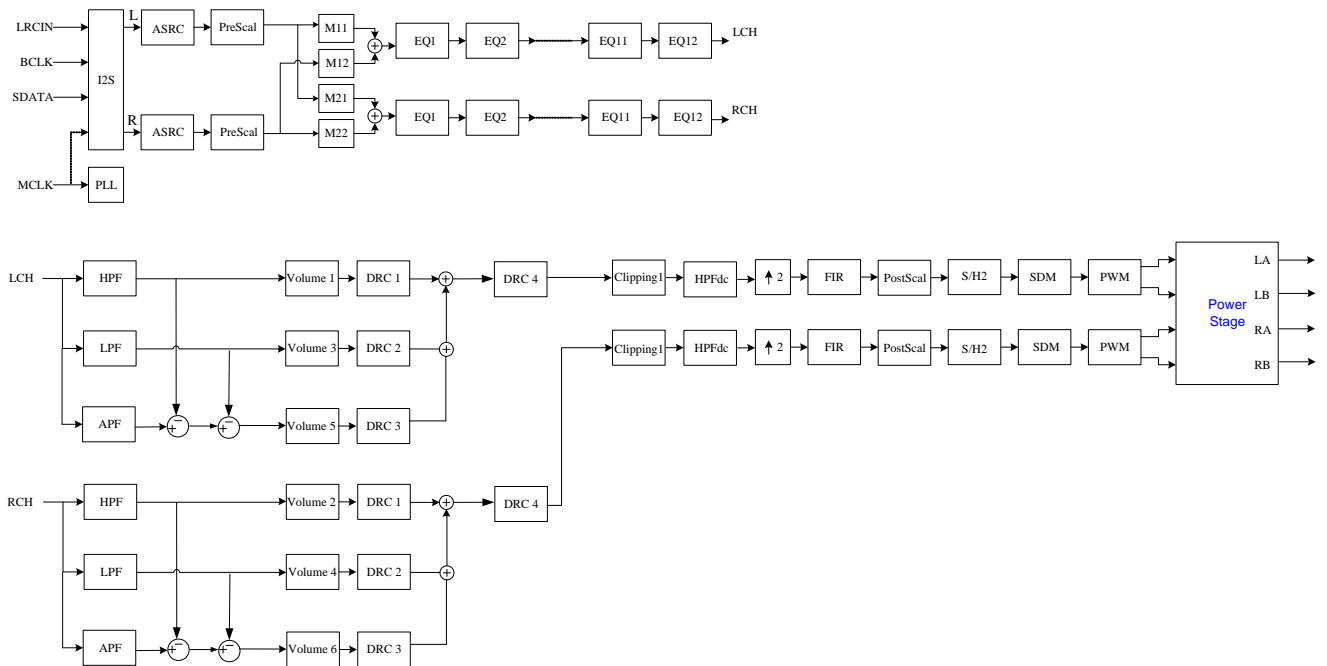

Address	Name	B[7]	B[6]	B[5]	B[4]	B[3]	B[2]	B[1]	B[0]
0X00	SCTL1	IF[2]	IF[1]	IF[0]	Reserved	PWML_X	PWML_X	LV_UVSEL	LREXC
0X01	SCTL2	BCLK_SEL	FS[1]	FS[0]	FS8K	PMF[3]	PMF[2]	PMF[1]	PMF[0]
0X02	SCTL3	EN_CLK_OUT	MUTE	CM1	CM2	CM3	CM4	CM5	CM6
0X03	MVOL	MV[7]	MV[6]	MV[5]	MV[4]	MV[3]	MV[2]	MV[1]	MV[0]
0X04	C1VOL	C1V[7]	C1V[6]	C1V[5]	C1V[4]	C1V[3]	C1V[2]	C1V[1]	C1V[0]
0X05	C2VOL	C2V[7]	C2V[6]	C2V[5]	C2V[4]	C2V[3]	C2V[2]	C2V[1]	C2V[0]
0X06	C3VOL	C3V[7]	C3V[6]	C3V[5]	C3V[4]	C3V[3]	C3V[2]	C3V[1]	C3V[0]
0X07	C4VOL	C4V[7]	C4V[6]	C4V[5]	C4V[4]	C4V[3]	C4V[2]	C4V[1]	C4V[0]
0X08	C5VOL	C5V[7]	C5V[6]	C5V[5]	C5V[4]	C5V[3]	C5V[2]	C5V[1]	C5V[0]
0X09	C6VOL	C6V[7]	C6V[6]	C6V[5]	C6V[4]	C6V[3]	C6V[2]	C6V[1]	C6V[0]
0X0A	BTONE	Reserved			BTC[4]	BTC[3]	BTC[2]	BTC[1]	BTC[0]
0X0B	TTONE	Reserved			TTC[4]	TTC[3]	TTC[2]	TTC[1]	TTC[0]
0X0C	SCTL4	SRBP	BTE	DEQE	NGE	EQL	PSL	DSPB	HPB
0X0D	C1CFG	Reserved				C1PCBP	C1DRCBP	Reserved	C1VBP
0X0E	C2CFG	Reserved				C2PCBP	C2DRCBP	Reserved	C2VBP
0X0F	C3CFG	Reserved				C3DRCBP		Reserved	C3VBP
0X10	C4CFG	Reserved				C4DRCBP		Reserved	C4VBP
0X11	C5CFG	Reserved				C5DRCBP		Reserved	C5VBP

0X12	C6CFG	Reserved					C6DRCBP	Reserved	C6VBP
0X13	C7CFG	Reserved					C7DRCBP	Reserved	Reserved
0X14	C8CFG	Reserved					C8DRCBP	Reserved	Reserved
0X15	LAR1	LA1[3]	LA1[2]	LA1[1]	LA1[0]	LR1[3]	LR1[2]	LR1[1]	LR1[0]
0X16	LAR2	LA2[3]	LA2[2]	LA2[1]	LA2[0]	LR2[3]	LR2[2]	LR2[1]	LR2[0]
0X17	LAR3	LA3[3]	LA3[2]	LA3[1]	LA3[0]	LR3[3]	LR3[2]	LR3[1]	LR3[0]
0X18	LAR4	LA4[3]	LA4[2]	LA4[1]	LA4[0]	LR4[3]	LR4[2]	LR4[1]	LR4[0]
0X19	ERDLY	Prohibited							
0X1A	SCTL5	Reserved	MONO_EN	SW_RSTB	LVUV_FADE	Reserved	DIS_MCLK_DET	QT_EN	PWM_SEL
0X1B	SCTL6	DIS_HVUV	DRC_SEL[1]	DRC_SEL[0]	Reserved		HV_UVSEL [2]	HV_UVSEL [1]	HV_UVSEL [0]
0X1C	SCTL7	Reserved	A_SEL_FAULT	D_MOD	DIS_NG_FADE	QD_EN	FADE_SPEED	NG_GAIN[1]	NG_GAIN[0]
0X1D	CFADDR	CFA[7]	CFA[6]	CFA[5]	CFA[4]	CFA[3]	CFA[2]	CFA[1]	CFA[0]
0X1E	A1CF1	C1B[23]	C1B[22]	C1B[21]	C1B[20]	C1B[19]	C1B[18]	C1B[17]	C1B[16]
0X1F	A1CF2	C1B[15]	C1B[14]	C1B[13]	C1B[12]	C1B[11]	C1B[10]	C1B[9]	C1B[8]
0X20	A1CF3	C1B[7]	C1B[6]	C1B[5]	C1B[4]	C1B[3]	C1B[2]	C1B[1]	C1B[0]
0X21	A2CF1	C2B[23]	C2B[22]	C2B[21]	C2B[20]	C2B[19]	C2B[18]	C2B[17]	C2B[16]
0X22	A2CF2	C2B[15]	C2B[14]	C2B[13]	C2B[12]	C2B[11]	C2B[10]	C2B[9]	C2B[8]
0X23	A2CF3	C2B[7]	C2B[6]	C2B[5]	C2B[4]	C2B[3]	C2B[2]	C2B[1]	C2B[0]
0X24	B1CF1	C3B[23]	C3B[22]	C3B[21]	C3B[20]	C3B[19]	C3B[18]	C3B[17]	C3B[16]
0X25	B1CF2	C3B[15]	C3B[14]	C3B[13]	C3B[12]	C3B[11]	C3B[10]	C3B[9]	C3B[8]
0X26	B1CF3	C3B[7]	C3B[6]	C3B[5]	C3B[4]	C3B[3]	C3B[2]	C3B[1]	C3B[0]
0X27	B2CF1	C4B[23]	C4B[22]	C4B[21]	C4B[20]	C4B[19]	C4B[18]	C4B[17]	C4B[16]
0X28	B2CF2	C4B[15]	C4B[14]	C4B[13]	C4B[12]	C4B[11]	C4B[10]	C4B[9]	C4B[8]
0X29	B2CF3	C4B[7]	C4B[6]	C4B[5]	C4B[4]	C4B[3]	C4B[2]	C4B[1]	C4B[0]
0X2A	A0CF1	C5B[23]	C5B[22]	C5B[21]	C5B[20]	C5B[19]	C5B[18]	C5B[17]	C5B[16]
0X2B	A0CF2	C5B[15]	C5B[14]	C5B[13]	C5B[12]	C5B[11]	C5B[10]	C5B[9]	C5B[8]
0X2C	A0CF3	C5B[7]	C5B[6]	C5B[5]	C5B[4]	C5B[3]	C5B[2]	C5B[1]	C5B[0]
0X2D	CFRW	Reserved	RBS	R3	W3	RA	R1	WA	W1
0X2E	PRS	Prohibited							
0X2F	MBIST	Prohibited							
0X30	Reserved	Reserved							
0X31	PWM_CTRL	Prohibited							
0X32	TM_CTRL	Prohibited							
0X33	QT_SW_LEVEL	SW_LEVEL [2]	SW_LEVEL [1]	SW_LEVEL [0]	QT_SW_LEVEL [4]	QT_SW_LEVEL [3]	QT_SW_LEVEL [2]	QT_SW_LEVEL [1]	QT_SW_LEVEL [0]
0X34	VFT1	MV_FT[1]	MV_FT[0]	C1V_FT[1]	C1V_FT[0]	C2V_FT[1]	C2V_FT[0]	C3V_FT[1]	C3V_FT[0]
0X35	VFT2	C4V_FT[1]	C4V_FT[0]	C5V_FT[1]	C5V_FT[0]	C6V_FT[1]	C6V_FT[0]	Reserved	

0X36	OCB_GVDDS	Prohibited							
0X37	ID	DN[3]	DN[2]	DN[1]	DN[0]	VN[3]	VN[2]	VN[1]	VN[0]
0X38	R1ADDR	Prohibited							
0X39	R1D1	Prohibited							
0X3A	R1D2	Prohibited							
0X3B	R1D3	Prohibited							
0X3C	R1RW	Prohibited							
0X3D	R2ADDR	Prohibited							
0X3E	R2D1	Prohibited							
0X3F	R2D2	Prohibited							
0X40	R2D3	Prohibited							
0X41	R2RW	Prohibited							
0X42	LMC	C1_CLR	C2_CLR	C3_CLR	C4_CLR	C5_CLR	C6_CLR	C7_CLR	C8_CLR
0X43	PMC	C1_CLR_RMS	C2_CLR_RMS	C3_CLR_RMS	C4_CLR_RMS	C5_CLR_RMS	C6_CLR_RMS	C7_CLR_RMS	C8_CLR_RMS
0X44	TC1LM	C1_LEVEL[23]	C1_LEVEL[22]	C1_LEVEL[21]	C1_LEVEL[20]	C1_LEVEL[19]	C1_LEVEL[18]	C1_LEVEL[17]	C1_LEVEL[16]
0X45	MC1LM	C1_LEVEL[15]	C1_LEVEL[14]	C1_LEVEL[13]	C1_LEVEL[12]	C1_LEVEL[11]	C1_LEVEL[10]	C1_LEVEL[9]	C1_LEVEL[8]
0X46	BC1LM	C1_LEVEL[7]	C1_LEVEL[6]	C1_LEVEL[5]	C1_LEVEL[4]	C1_LEVEL[3]	C1_LEVEL[2]	C1_LEVEL[1]	C1_LEVEL[0]
0X47	TC2LM	C2_LEVEL[23]	C2_LEVEL[22]	C2_LEVEL[21]	C2_LEVEL[20]	C2_LEVEL[19]	C2_LEVEL[18]	C2_LEVEL[17]	C2_LEVEL[16]
0X48	MC2LM	C2_LEVEL[15]	C2_LEVEL[14]	C2_LEVEL[13]	C2_LEVEL[12]	C2_LEVEL[11]	C2_LEVEL[10]	C2_LEVEL[9]	C2_LEVEL[8]
0X49	BC2LM	C2_LEVEL[7]	C2_LEVEL[6]	C2_LEVEL[5]	C2_LEVEL[4]	C2_LEVEL[3]	C2_LEVEL[2]	C2_LEVEL[1]	C2_LEVEL[0]
0X4A	TC3LM	C3_LEVEL[23]	C3_LEVEL[22]	C3_LEVEL[21]	C3_LEVEL[20]	C3_LEVEL[19]	C3_LEVEL[18]	C3_LEVEL[17]	C3_LEVEL[16]
0X4B	MC3LM	C3_LEVEL[15]	C3_LEVEL[14]	C3_LEVEL[13]	C3_LEVEL[12]	C3_LEVEL[11]	C3_LEVEL[10]	C3_LEVEL[9]	C3_LEVEL[8]
0X4C	BC3LM	C3_LEVEL[7]	C3_LEVEL[6]	C3_LEVEL[5]	C3_LEVEL[4]	C3_LEVEL[3]	C3_LEVEL[2]	C3_LEVEL[1]	C3_LEVEL[0]
0X4D	TC4LM	C4_LEVEL[23]	C4_LEVEL[22]	C4_LEVEL[21]	C4_LEVEL[20]	C4_LEVEL[19]	C4_LEVEL[18]	C4_LEVEL[17]	C4_LEVEL[16]
0X4E	MC4LM	C4_LEVEL[15]	C4_LEVEL[14]	C4_LEVEL[13]	C4_LEVEL[12]	C4_LEVEL[11]	C4_LEVEL[10]	C4_LEVEL[9]	C4_LEVEL[8]
0X4F	BC4LM	C4_LEVEL[7]	C4_LEVEL[6]	C4_LEVEL[5]	C4_LEVEL[4]	C4_LEVEL[3]	C4_LEVEL[2]	C4_LEVEL[1]	C4_LEVEL[0]
0X50	TC5LM	C5_LEVEL[23]	C5_LEVEL[22]	C5_LEVEL[21]	C5_LEVEL[20]	C5_LEVEL[19]	C5_LEVEL[18]	C5_LEVEL[17]	C5_LEVEL[16]
0X51	MC5LM	C5_LEVEL[15]	C5_LEVEL[14]	C5_LEVEL[13]	C5_LEVEL[12]	C5_LEVEL[11]	C5_LEVEL[10]	C5_LEVEL[9]	C5_LEVEL[8]
0X52	BC5LM	C5_LEVEL[7]	C5_LEVEL[6]	C5_LEVEL[5]	C5_LEVEL[4]	C5_LEVEL[3]	C5_LEVEL[2]	C5_LEVEL[1]	C5_LEVEL[0]
0X53	TC6LM	C6_LEVEL[23]	C6_LEVEL[22]	C6_LEVEL[21]	C6_LEVEL[20]	C6_LEVEL[19]	C6_LEVEL[18]	C6_LEVEL[17]	C6_LEVEL[16]
0X54	MC6LM	C6_LEVEL[15]	C6_LEVEL[14]	C6_LEVEL[13]	C6_LEVEL[12]	C6_LEVEL[11]	C6_LEVEL[10]	C6_LEVEL[9]	C6_LEVEL[8]
0X55	BC6LM	C6_LEVEL[7]	C6_LEVEL[6]	C6_LEVEL[5]	C6_LEVEL[4]	C6_LEVEL[3]	C6_LEVEL[2]	C6_LEVEL[1]	C6_LEVEL[0]
0X56	TC7LM	C7_LEVEL[23]	C7_LEVEL[22]	C7_LEVEL[21]	C7_LEVEL[20]	C7_LEVEL[19]	C7_LEVEL[18]	C7_LEVEL[17]	C7_LEVEL[16]
0X57	MC7LM	C7_LEVEL[15]	C7_LEVEL[14]	C7_LEVEL[13]	C7_LEVEL[12]	C7_LEVEL[11]	C7_LEVEL[10]	C7_LEVEL[9]	C7_LEVEL[8]
0X58	BC7LM	C7_LEVEL[7]	C7_LEVEL[6]	C7_LEVEL[5]	C7_LEVEL[4]	C7_LEVEL[3]	C7_LEVEL[2]	C7_LEVEL[1]	C7_LEVEL[0]
0X59	TC8LM	C8_LEVEL[23]	C8_LEVEL[22]	C8_LEVEL[21]	C8_LEVEL[20]	C8_LEVEL[19]	C8_LEVEL[18]	C8_LEVEL[17]	C8_LEVEL[16]

0X5A	MC8LM	C8_LEVEL[15]	C8_LEVEL[14]	C8_LEVEL[13]	C8_LEVEL[12]	C8_LEVEL[11]	C8_LEVEL[10]	C8_LEVEL[9]	C8_LEVEL[8]	
0X5B	BC8LM	C8_LEVEL[7]	C8_LEVEL[6]	C8_LEVEL[5]	C8_LEVEL[4]	C8_LEVEL[3]	C8_LEVEL[2]	C8_LEVEL[1]	C8_LEVEL[0]	
0X5C	I2S_OUT	Reserved					I2S_DO_SEL[2]	I2S_DO_SEL[2]	I2S_DO_SEL[2]	
0X5D~ 0X73	Reserved	Reserved								
0X74	MKHB	MK_HBYTE[7]	MK_HBYTE[6]	MK_HBYTE[5]	MK_HBYTE[4]	MK_HBYTE[3]	MK_HBYTE[2]	MK_HBYTE[1]	MK_HBYTE[0]	
0X75	MKLB	MK_LBYTE[7]	MK_LBYTE[6]	MK_LBYTE[5]	MK_LBYTE[4]	MK_LBYTE[3]	MK_LBYTE[2]	MK_LBYTE[1]	MK_LBYTE[0]	
0X76	BS_CTRL	Prohibited								
0X77	HI_RES	Prohibited								
0X78	TMR	Prohibited								
0X79	BS_OV_UV_SEL	Prohibited								
0X7A	OC_SEL	Prohibited								
0X7B	MBIST_UPT_E	Prohibited								
0X7C	MBIST_UPM_E	Prohibited								
0X7D	MBIST_UPB_E	Prohibited								
0X7E	MBIST_UPT_O	Prohibited								
0X7F	MBIST_UPM_O	Prohibited								
0X80	MBIST_UPB_O	Prohibited								
0X81	Reserved	Reserved								
0X82	MDT	Prohibited								
0X83	PWM SHIFT	Reserved								
0X84	ERR_REG	A_OCP_N	A_OTP_N	A_UV_N	A_BSUV	A_BSOV	A_CKERR	A_OVP	Reserved	
0X85	ERR_RECORD	A_OCP_N_LATCH	A_OTP_N_LATCH	A_UV_N_LATCH	A_BSUV_LATCH	A_BSOV_LATCH	A_CKERR_LATCH	A_OVP_LATCH	Reserved	
0X86	ERR_CLEAR	A_OCP_N_CLEAR	A_OTP_N_CLEAR	A_UV_N_CLEAR	A_BSUV_CLEAR	A_BSOV_CLEAR	A_CKERR_CLEAR	A_OVP_CLEAR	Reserved	

Detail Description for Register

Note that the highlighted columns are default values of these tables. If there is no highlighted value, the default setting of this bit is determined by the external pin.

- Address 0X00 : State control 1

AD82584F supports multiple serial data input formats including I²S, Left-alignment and Right-alignment.

These formats are selected by user via bit7~bit5 of address 0X00. The left/right channels can be exchanged to each other by programming to address 0/bit0, LREXC.

BIT	NAME	DESCRIPTION	VALUE	FUNCTION
B[7:5]	IF[2:0]	Input Format	000	I ² S 16-24 bits
			001	Left-alignment 16-24 bits
			010	Right-alignment 16 bits
			011	Right-alignment 18 bits
			100	Right-alignment 20 bits
			101	Right-alignment 24 bits
B[4]		Reserved		
B[3]	PWML_X	LA/LB exchange	0	No exchanged
			1	L/R exchanged
B[2]	PWMR_X	RA/RB exchange	0	L/R exchanged
			1	No exchanged
B[1]	LV_UVSEL	LV under voltage selection	0	2.9V
			1	2.7V
B[0]	LREXC	Left/Right (L/R) Channel exchanged	0	No exchanged
			1	L/R exchanged

● Address 0X01 : State control 2

AD82584F has a built-in PLL and supports multiple MCLK/Fs or BCLK/Fs ratios.

If BCLK_SEL is high, the ratio is changed to BCLK/FS ratios.

On the contrary, the ratio is changed to MCLK/FS ratios.

AD82584F has 8K sample rate application via bit 4.

Detail setting is shown in the following table.

BIT	NAME	DESCRIPTION	VALUE	FUNCTION
B[7]	BCLK_SEL	MCLK-less (BCLK system)	0	Disable
			1	Enable
B[6:5]	FS[1:0]	Sampling Frequency	00	32/44.1/48kHz
			01	64/88.2/96kHz
			1x	128/176.4/192kHz
B[4]	FS8K	8K sample rate	0	Disable
			1	Enable

Note that: 8K application needs MCLK pin. Therefore, E-LQFP-48 and E-TSSOP-28 package can support this function.

Multiple MCLK/FS in MCLK system or BCLK/FS in BCLK system ratio setting table

BIT	NAME	DESCRIPTION	VALUE	B[6:5]=00	B[6:5]=01	B[6:5]=1x
B[3:0]	PMF[3:0]	MCLK/Fs or BCLK/Fs Setup	0000	1024x	512x	256x
			0001	Reset Default (64x)	Reset Default (64x)	Reset Default (64x)
			0010	128x	128x	128x
			0011	192x	192x	192x
			0100	256x	256x	256x
			0101	384x	384x	Reserved
			0110	512x	512x	
			0111	576x	Reserved	
			1000	768x		
			1001	1024x		

Multiple MCLK/FS ratio setting table of 8K application

BIT	NAME	DESCRIPTION	VALUE	B[4]=1
B[3:0]	PMF[3:0]	MCLK/Fs Setup	0000	4096x
			0001	Reset Default (256x)
			0010	512x
			0011	768x
			0100	1024x
			0101	1536x
			0110	2048x
			0111	2304x
			1000	3072x
			1001	4096x

● Address 0X02 : State control 3

AD82584F has mute function including master mute and channel mute.

In one band DRC, master, channel 1, and channel 2 mute will active.

When master mute is enabled, all 2 processing channels are muted. User can mute these 2 channels individually by channel mute. When the mute function is enabled or disabled, the fade-out or fade-in process will be initiated.

In three bands DRC, master, channel 1 to channel 6 mute will active.

When master mute is enabled, all 6 processing channels are muted. User can mute these 6 channels individually by channel mute. When the mute function is enabled or disabled, the fade-out or fade-in process will be initiated.

BIT	NAME	DESCRIPTION	VALUE	FUNCTION
B[7]	EN_CLK_OUT	PLL Clock Output	0	Disabled
			1	Enabled
B[6]	MMUTE	Master Mute	0	All channel not muted
			1	All channel muted
B[5]	CM1	Channel 1 Mute	0	Ch1 not muted
			1	Only Ch1 muted
B[4]	CM2	Channel 2 Mute	0	Ch2 not muted
			1	Only Ch2 muted
B[3]	CM3	Channel 3 Mute	0	Ch3 not muted
			1	Only Ch3 muted
B[2]	CM4	Channel 4 Mute	0	Ch4 not muted
			1	Only Ch4 muted
B[1]	CM5	Channel 5 Mute	0	Ch5 not muted
			1	Only Ch5 muted
B[0]	CM6	Channel 6 Mute	0	Ch6 not muted
			1	Only Ch6 muted

● Address 0X03 : Master volume control

AD82584F supports both master-volume (Address 0X03) and channel-volume control (Address 0X04, 0X05, 0X06, 0X07, 0X08, 0X09) modes. Both volume control settings range from +12dB ~ -103dB and 0.5dB per step. Note that the master volume control is added to the individual channel volume control as the total volume control. For example, if the master volume level is set at, Level A (in dB unit) and the channel volume level is set at Level B (in dB unit), the total volume control setting is equal to Level A plus with Level B.

$$-103\text{dB} \leq \text{Total volume (Level A + Level B)} \leq +24\text{dB}.$$

BIT	NAME	DESCRIPTION	VALUE	FUNCTION
BIT[7:0]	MV[7:0]	Master Volume	00000000	+12.0dB
			00000001	+11.5dB
			00000010	+11.0dB
			:	:
			00010111	+0.5dB
			00011000	0.0dB
			00011001	-0.5dB
			:	:
			11100110	-103.0dB
			11100111	$-\infty$ dB
			:	:
			11111111	$-\infty$ dB

● Address 0X04 : Channel 1 volume

BIT	NAME	DESCRIPTION	VALUE	FUNCTION
BIT[7:0]	C1V[7:0]	Channel1 Volume	00000000	+12.0dB
			00000001	+11.5dB
			:	:
			00010100	+2dB
			:	:
			00011000	0.0dB
			00011001	-0.5dB
			:	:
			11100110	-103.0dB
			11100111	$-\infty$ dB
			:	:
			11111111	$-\infty$ dB

- Address 0X05 : Channel 2 volume

BIT	NAME	DESCRIPTION	VALUE	FUNCTION
BIT[7:0]	C2V[7:0]	Channel2 Volume	00000000	+12.0dB
			00000001	+11.5dB
			:	:
			00010100	+2dB
			:	:
			00011000	0.0dB
			00011001	-0.5dB
			:	:
			11100110	-103.0dB
			11100111	-∞dB
			:	:
			11111111	-∞dB

- Address 0X06 : Channel 3 volume

BIT	NAME	DESCRIPTION	VALUE	FUNCTION
BIT[7:0]	C3V[7:0]	Channel3 Volume	00000000	+12.0dB
			00000001	+11.5dB
			:	:
			00010100	+2dB
			:	:
			00011000	0.0dB
			00011001	-0.5dB
			:	:
			11100110	-103.0dB
			11100111	-∞dB
			:	:
			11111111	-∞dB

- Address 0X07 : Channel 4 volume

BIT	NAME	DESCRIPTION	VALUE	FUNCTION
BIT[7:0]	C4V[7:0]	Channel 4 Volume	00000000	+12.0dB
			00000001	+11.5dB
			:	:
			00010100	+2dB
			:	:
			00011000	0.0dB
			00011001	-0.5dB
			:	:
			11100110	-103.0dB
			11100111	-∞dB
			:	:
			11111111	-∞dB

- Address 0X08 : Channel 5 volume

BIT	NAME	DESCRIPTION	VALUE	FUNCTION
BIT[7:0]	C5V[7:0]	Channel 5 Volume	00000000	+12.0dB
			00000001	+11.5dB
			:	:
			00010100	+2dB
			:	:
			00011000	0.0dB
			00011001	-0.5dB
			:	:
			11100110	-103.0dB
			11100111	-∞dB
			:	:
			11111111	-∞dB

- Address 0X09 : Channel 6 volume

BIT	NAME	DESCRIPTION	VALUE	FUNCTION
BIT[7:0]	C6V[7:0]	Channel 6 Volume	00000000	+12.0dB
			00000001	+11.5dB
			:	:
			00010100	+2dB
			:	:
			00011000	0.0dB
			00011001	-0.5dB
			:	:
			11100110	-103.0dB
			11100111	-∞dB
			:	:
			11111111	-∞dB

- Address 0X0A/0X0B : Bass/Treble tone boost and cut

EQ11 and EQ12 can be programmed as bass/treble tone boost and cut. When, register with address-0X0C, bit-6, BTE is set to high, the EQ-11 and EQ-12 will perform as bass and treble respectively. The -3dB corner frequency of bass is 360Hz, and treble is 7kHz. The gain range for both filters is +12db ~ -12dB with 1dB per step.

BIT	NAME	DESCRIPTION	VALUE	FUNCTION
B[7:5]		Reserved		
B[4:0]	BTC[4:0] / TTC[4:0]	The gain setting of boost and cut	00000	+12dB
		
			00100	+12dB
			00101	+11dB
			00110	+10dB
		
			01110	+2dB
			01111	+1dB
			10000	0dB
			10001	-1dB
			10010	-2dB
		
			11010	-10dB
			11011	-11dB
			11100	-12dB
...	...			
11111	-12dB			

- Address 0X0C : State control 4

The AD82584F provides several DSP setting as following.

BIT	NAME	DESCRIPTION	VALUE	FUNCTION
B[7]	SRBP	Surround bypass	0	Surround enable
			1	Surround bypass
B[6]	BTE	Bass/Treble Selection bypass	0	Bass/Treble Disable
			1	Bass/Treble Enable
B[5]	DEQE	Dynamic EQ enable	0	DEQ Disable
			1	DEQ enable
B[4]	NGE	Noise gate enable	0	Noise gate disable
			1	Noise gate enable
B[3]	EQL	EQ Link	0	Each channel uses individual EQ
			1	Channel-2 uses channel-1 EQ
B[2]	PSL	Post-scale link	0	Each channel uses individual post-scale
			1	Use channel-1 post-scale
B[1]	DSPB	EQ bypass	0	EQ enable
			1	EQ bypass
B[0]	HPB	DC blocking HPF bypass	0	HPF dc enable
			1	HPF dc bypass

- Address 0X0D, 0X0E ,0X0F,0X10,0X11,0X12, 0X13,0X14 : Channel configuration registers

AD82584F can configure each channel to enable or bypass DRC and channel volume and select the limiter set.

Address 0X0D and 0X0E; where x=1 or 2

BIT	NAME	DESCRIPTION	VALUE	FUNCTION
B[7:4]		Reserved		
B[3]	CxPCBP	Channel x Power Clipping bypass	0	Channel x PC enable
			1	Channel x PC bypass
B[2]	CxDRCBP	Channel x DRC bypass	0	Channel x DRC enable
			1	Channel x DRC bypass
B[1]		Reserved		
B[0]	CxVBP	Channel x Volume bypass	0	Channel x's master volume operation
			1	Channel x's master volume bypass

Address 0X0F, 0X10, 0X11, and 0X12; where x=3, 4, 5, 6

BIT	NAME	DESCRIPTION	VALUE	FUNCTION
B[7:3]		Reserved		
B[2]	CxDRCBP	Channel x DRC bypass	0	Channel x DRC enable
			1	Channel x DRC bypass
B[1]		Reserved		
B[0]	CxVBP	Channel x Volume bypass	0	Channel x volume operation
			1	Channel x volume bypass

Address 0X13, and 0X14; where x=7 or 8

C7DRCBP/C8DRCBP use to control L/R post DRC.

The gains are internally setting and they can't be changed via I2C control.

BIT	NAME	DESCRIPTION	VALUE	FUNCTION
B[7:3]		Reserved		
B[2]	CxDRCBP	Channel x DRC bypass	0	Channel x DRC enable
			1	Channel x DRC bypass
B[1:0]		Reserved		

● Address 0X15, 0X16, 0X17, 0X18 : DRC limiter attack/release rate

The AD82584F has 4 independent DRC set, each DRC has its own attack/release rate.

Address 0X15, 0X16, 0X17, and 0X18; where x=1, 2, 3, 4

BIT	NAME	DESCRIPTION	VALUE	FUNCTION
B[7:5]	LAx[3:0]	DRC attack rate	0000	3 dB/ms
			0001	2.667 dB/ms
			0010	2.182 dB/ms
			0011	1.846 dB/ms
			0100	1.333 dB/ms
			0101	0.889 dB/ms
			0110	0.4528 dB/ms
			0111	0.2264 dB/ms
			1000	0.15 dB/ms
			1001	0.1121 dB/ms
			1010	0.0902 dB/ms
			1011	0.0752 dB/ms
			1100	0.0645 dB/ms
			1101	0.0563 dB/ms
			1110	0.0501 dB/ms
			1111	0.0451 dB/ms
B[3:0]	LRx[3:0]	DRC release rate	0000	0.5106 dB/ms
			0001	0.1371 dB/ms
			0010	0.0743 dB/ms
			0011	0.0499 dB/ms
			0100	0.0360 dB/ms
			0101	0.0299 dB/ms
			0110	0.0264 dB/ms
			0111	0.0208 dB/ms
			1000	0.0198 dB/ms
			1001	0.0172 dB/ms
			1010	0.0147 dB/ms
			1011	0.0137 dB/ms
			1100	0.0134 dB/ms
			1101	0.0117 dB/ms
			1110	0.0112 dB/ms
			1111	0.0104 dB/ms

● Address 0X1A : State control 5

BIT	NAME	DESCRIPTION	VALUE	FUNCTION
B[7]		Reserved		
B[6]	MONO_EN	MONO enable register	0	Stereo
			1	MONO_EN=1 and MONO_KEY=3006(hex) Output will become mono
B[5]	SW_RSTB	Software reset	0	Reset
			1	Normal operation
B[4]	LVUV_FADE	Low Under Voltage Fade	0	No Fade
			1	Fade
B[3]		Reserved		
B[2]	DIS_MCLK_DET	Disable MCLK detect circuit	0	Enable MCLK detect circuit
			1	Disable MCLK detect circuit
B[1]	QT_EN	Power saving mode	0	Disable
			1	Enable
B[0]	PWM_SEL	PWM modulation	0	Qua-ternary
			1	Ternary

- Address 0X1B : State control 6

AD82584F can disable HV under voltage detection via bit 7.

AD82584F support multi-level HV under voltage detection via bit2~ bit0, using this function, AD82584F will fade out signal to avoid pop sounds if high voltage supply disappear before low voltage supply.

AD82584F can support one band, two band, and three band DRC selection via bit6~bit5.

BIT	NAME	DESCRIPTION	VALUE	FUNCTION
B[7]	DIS_HVUV	Disable HV under voltage selection	0	Enable
			1	Disable
B[6:5]	DRC_SEL	DRC mode selection	00	One band DRC
			01	Two band DRC
			1X	Three band DRC
B[4:3]		Reserved		
B[2:0]	HV_UV SEL	UV detection level	000	4V
			001	7.2V
			010	9.7 V
			011	13.2V
			100	15.5 V
			101	19.5 V
			Others	7.2V

- Address 0X1C: State control 7

The $\overline{\text{ERROR}}$ pin of AD82584F is a dual function pin. It is treated as a I²C device address selection input when B[6] is set as low. It will become as an ERROR output pin when B[6] is set as high.

AD82584F can turn on delta quaternary modulation via bit 5.

AD82584F provide 2 kind of fade in/out speed via bit 2. One is 1.25ms from mute to 0dB. The other one is 10ms from mute to 0dB.

AD82584F provide noise gate function if receiving 2048 signal sample points smaller than noise gate attack level. User can change noise gate gain via bit1~ bit0. When noise gate function occurs, input signal will multiply noise gate gain (x1/8, x1/4 x1/2, x0). User can select fade out or not via bit 4.

BIT	NAME	DESCRIPTION	VALUE	FUNCTION
B[7]	X	Reserved		
B[6]	A_SEL_FAULT	I2C address selection or ERROR output	0	I2C device address selection
			1	ERROR output
B[5]	D_MOD	Delta quaternary modulation	0	Disable
			1	enable
B[4]	DIS_NG_FADE	Disable noise gate fade	0	Fade
			1	No fade
B[3]	QD_EN	Quaternary and delta quaternary switching	0	Disable
			1	enable
B[2]	FADE_SPEED	Fade in/out speed selection	0	1.25ms
			1	10ms
B[1:0]	NG_GAIN[1:0]	Noise gate gain	00	x1/8
			01	x1/4
			10	x1/2
			11	Mute

- Address 0X1D ~0X2D : User-defined coefficients registers

An on-chip RAM in AD82584F stores user-defined EQ, mixing, pre-scale, post-scale coefficients...etc. The content of this coefficient RAM is indirectly accessed via coefficient registers, which consist of one base address register (address 0X1D), five sets of registers (address 0X1E to 0X2C) of three consecutive 8-bit entries for each 24-bit coefficient, and one control register (address 0X2D) to control access of the coefficients in the RAM..

Address 0X1D

BIT	NAME	DESCRIPTION	VALUE	FUNCTION
B[7:0]	CFA[7:0]	Coefficient RAM base address	00000000	

Address 0X1E, A1cf1

BIT	NAME	DESCRIPTION	VALUE	FUNCTION
B[7:0]	C1B[23:16]	Top 8-bits of coefficients A1		

Address 0X1F, A1cf2

BIT	NAME	DESCRIPTION	VALUE	FUNCTION
B[7:0]	C1B[15:8]	Middle 8-bits of coefficients A1		

Address 0X20, A1cf3

BIT	NAME	DESCRIPTION	VALUE	FUNCTION
B[7:0]	C1B[7:0]	Bottom 8-bits of coefficients A1		

Address 0X21, A2cf1

BIT	NAME	DESCRIPTION	VALUE	FUNCTION
B[7:0]	C2B[23:16]	Top 8-bits of coefficients A2		

Address 0X22, A2cf2

BIT	NAME	DESCRIPTION	VALUE	FUNCTION
B[7:0]	C2B[15:8]	Middle 8-bits of coefficients A2		

Address 0X23, A2cf3

BIT	NAME	DESCRIPTION	VALUE	FUNCTION
B[7:0]	C2B[7:0]	Bottom 8-bits of coefficients A2		

Address 0X24, B1cf1

BIT	NAME	DESCRIPTION	VALUE	FUNCTION
B[7:0]	C3B[23:16]	Top 8-bits of coefficients B1		

Address 0X25, B1cf2

BIT	NAME	DESCRIPTION	VALUE	FUNCTION
B[7:0]	C3B[15:8]	Middle 8-bits of coefficients B1		

Address 0X26, B1cf3

BIT	NAME	DESCRIPTION	VALUE	FUNCTION
B[7:0]	C3B[7:0]	Bottom 8-bits of coefficients B1		

Address 0X27, B2cf1

BIT	NAME	DESCRIPTION	VALUE	FUNCTION
B[7:0]	C4B[23:16]	Top 8-bits of coefficients B2		

Address 0X28, B2cf2

BIT	NAME	DESCRIPTION	VALUE	FUNCTION
B[7:0]	C4B[15:8]	Middle 8-bits of coefficients B2		

Address 0X29, B2cf3

BIT	NAME	DESCRIPTION	VALUE	FUNCTION
B[7:0]	C4B[7:0]	Bottom 8-bits of coefficients B2		

Address 0X2A, A0cf1

BIT	NAME	DESCRIPTION	VALUE	FUNCTION
B[7:0]	C5B[23:16]	Top 8-bits of coefficients A0		

Address 0X2B, A0cf2

BIT	NAME	DESCRIPTION	VALUE	FUNCTION
B[7:0]	C5B[15:8]	Middle 8-bits of coefficients A0		

Address 0X2C, A0cf3

BIT	NAME	DESCRIPTION	VALUE	FUNCTION
B[7:0]	C5B[7:0]	Bottom 8-bits of coefficients A0		

Address 0X2D, CfRW

BIT	NAME	DESCRIPTION	VALUE	FUNCTION
B[7]		Reserved		
B[6]	RBS	RAM bank selection	0	Select RAM bank 0
			1	Select RAM bank 1
B[5]	R3	Enable of reading three coefficients from RAM	0	Read complete
			1	Read enable
B[4]	W3	Enable of writing three coefficients to RAM	0	Write complete
			1	Write enable
B[3]	RA	Enable of reading a set of coefficients from RAM	0	Read complete
			1	Read enable
B[2]	R1	Enable of reading a single coefficient from RAM	0	Read complete
			1	Read enable
B[1]	WA	Enable of writing a set of coefficients to RAM	0	Write complete
			1	Write enable
B[0]	W1	Enable of writing a single coefficient to RAM	0	Write complete
			1	Write enable

● Address 0X33 : Power saving mode switching level

If the PWM exceeds the programmed switching power level (default 26*40ns), the modulation algorithm will change from default modulation scheme into power saving mode scheme. It results in higher power efficiency during larger power output operations. If the PWM drops below the programmed switching power level - programmed switching window (default (26-5)*40ns), the modulation algorithm will change back to default modulation scheme.

Switching scheme is related to QT_EN (address0X1A, B[1]), D_MOD(address0X1C, B[5]), and QD_EN(address0X1C, B[3]).

AD82584F has three type switching schemes and they share the same switching scheme.

One time will only have one switching scheme.

Case1: QT_EN=1, D_MOD=0, QD_EN=0. The default modulation scheme is quaternary and power saving mode scheme is ternary.

Case2: QT_EN=1, D_MOD=1, QD_EN=0. The default modulation scheme is delta quaternary and power saving mode scheme is ternary.

Case3: QT_EN=0, D_MOD=0, QD_EN=1. The default modulation scheme is quaternary and power saving mode scheme is delta quaternary.

BIT	NAME	DESCRIPTION	VALUE	FUNCTION
B[7:5]	SW_WINDOW	Power saving mode switching window	000	2
			001	3
			010	4
			011	5
			100	6
			101	7
			110	8
			111	9
B[4:0]	QT_SW_LEVEL	Power saving mode switching level	00000	4
			00001	4
			:	:
			01101	26
			01110	28
			01111	30
			10000	32
			:	:
			11110	60
			11111	62

- Address 0X34/0X35: Volume fine tune

AD82584F supports both master-volume fine tune and channel-volume control fine tune modes. Both volume control settings range from 0dB ~ -0.375dB and 0.125dB per step. Note that the master volume fine tune is added to the individual channel volume fine tune as the total volume fine tune.

Address 0X34

BIT	NAME	DESCRIPTION	VALUE	FUNCTION
B[7:6]	MV_FT	Master Volume Fine Tune	00	0dB
			01	-0.125dB
			10	-0.25dB
			11	-0.375dB
B[5:4]	C1V_FT	Channel 1 Volume Fine Tune	00	0dB
			01	-0.125dB
			10	-0.25dB
			11	-0.375dB
B[3:2]	C2V_FT	Channel 2 Volume Fine Tune	00	0dB
			01	-0.125dB
			10	-0.25dB
			11	-0.375dB
B[1:0]	C3V_FT	Channel 3 Volume Fine Tune	00	0dB
			01	-0.125dB
			10	-0.25dB
			11	-0.375dB

Address 0X35

BIT	NAME	DESCRIPTION	VALUE	FUNCTION
B[7:6]	C4V_FT	Channel 4 Volume Fine Tune	00	0dB
			01	-0.125dB
			10	-0.25dB
			11	-0.375dB
B[5:4]	C5V_FT	Channel 5 Volume Fine Tune	00	0dB
			01	-0.125dB
			10	-0.25dB
			11	-0.375dB
B[3:2]	C6V_FT	Channel 6 Volume Fine Tune	00	0dB
			01	-0.125dB
			10	-0.25dB
			11	-0.375dB
B[1:0]		Reserved		

● Address 0X37 : Device number and Version number

Device number and version number are the ID for the device.

BIT	NAME	DESCRIPTION	VALUE	FUNCTION
B[7:4]	DN	Device number	0101	Identification code
B[3:0]	VN	Version number	0010	Identification code

● Address 0X42 : level meter clear

AD82584F has 8 set of level meter which hold the maximum absolute value.

Each level meter has its own level meter clear.

BIT	NAME	DESCRIPTION	VALUE	FUNCTION
B[7]	C1_CLR	Clear CH1 level meter	0	No clear
			1	Clear
B[6]	C2_CLR	Clear CH2 level meter	0	No clear
			1	Clear
B[5]	C3_CLR	Clear CH3 level meter	0	No clear
			1	Clear
B[4]	C4_CLR	Clear CH4 level meter	0	No clear
			1	Clear

B[3]	C5_CLR	Clear CH5 level meter	0	No clear
			1	Clear
B[2]	C6_CLR	Clear CH6 level meter	0	No clear
			1	Clear
B[1]	C7_CLR	Clear CH7 level meter	0	No clear
			1	Clear
B[0]	C8_CLR	Clear CH8 level meter	0	No clear
			1	Clear

● Address 0X43 : Power meter clear

AD82584F has 8 set of level meter which continue update RMS value.

Each level meter has its own power meter clear.

BIT	NAME	DESCRIPTION	VALUE	FUNCTION
B[7]	C1_CLR_RMS	Clear CH1 power meter	0	No clear
			1	Clear
B[6]	C2_CLR_RMS	Clear CH2 power meter	0	No clear
			1	Clear
B[5]	C3_CLR_RMS	Clear CH3 power meter	0	No clear
			1	Clear
B[4]	C4_CLR_RMS	Clear CH4 power meter	0	No clear
			1	Clear
B[3]	C5_CLR_RMS	Clear CH5 level meter	0	No clear
			1	Clear
B[2]	C6_CLR_RMS	Clear CH6 level meter	0	No clear
			1	Clear
B[1]	C7_CLR_RMS	Clear CH7 level meter	0	No clear
			1	Clear
B[0]	C8_CLR_RMS	Clear CH8 level meter	0	No clear
			1	Clear

- Address 0X44 : Top 8 bit of C1 level meter

In one band DRC, channel-1 level meter is used for L channel.

In two/three bands DRC, channel-1 level meter is high frequency path of L channel.

The addresses to show channel-1 level meter are 0X44, 0X45, and 0X46.

BIT	NAME	DESCRIPTION	VALUE	FUNCTION
B[7:0]	C1_LEVEL_T	Top 8 bits of channel 1 level meter	0000000	Reset value
			X	Read out

- Address 0X45 : Middle 8 bit of C1 level meter

BIT	NAME	DESCRIPTION	VALUE	FUNCTION
B[7:0]	C1_LEVEL_M	Middle 8 bits of channel 1 level meter	0000000	Reset value
			X	Read out

- Address 0X46 : Bottom 8 bit of C1 level meter

BIT	NAME	DESCRIPTION	VALUE	FUNCTION
B[7:0]	C1_LEVEL_B	Bottom 8 bits of channel 1 level meter	0000000	Reset value
			X	Read out

- Address 0X47 : Top 8 bit of C2 level meter

In one band DRC, channel-2 level meter is used for R channel.

In two/three bands DRC, channel-2 level meter is high frequency path of R channel.

The addresses to show channel-2 level meter are 0X47, 0X48, and 0X49.

BIT	NAME	DESCRIPTION	VALUE	FUNCTION
B[7:0]	C2_LEVEL_T	Top 8 bits of channel 2 level meter	0000000	Reset value
			X	Read out

- Address 0X48 : Middle 8 bit of C2 level meter

BIT	NAME	DESCRIPTION	VALUE	FUNCTION
B[7:0]	C2_LEVEL_M	Middle 8 bits of channel 2 level meter	0000000	Reset value
			X	Read out

- Address 0X49 : Bottom 8 bit of C2 level meter

BIT	NAME	DESCRIPTION	VALUE	FUNCTION
B[7:0]	C2_LEVEL_B	Bottom 8 bits of channel 2 level meter	0000000	Reset value
			X	Read out

- Address 0X4A : Top 8 bit of C3 level meter

In one/two bands DRC, channel-3 level meter is no use.

In three bands DRC, channel-3 level meter is low frequency path of L channel.

The addresses to show channel-3 level meter are 0X4A, 0X4B, and 0X4C.

BIT	NAME	DESCRIPTION	VALUE	FUNCTION
B[7:0]	C3_LEVEL_T	Top 8 bits of channel 3 level meter	0000000	Reset value
			X	Read out

- Address 0X4B : Middle 8 bit of C3 level meter

BIT	NAME	DESCRIPTION	VALUE	FUNCTION
B[7:0]	C3_LEVEL_M	Middle 8 bits of channel 3 level meter	0000000	Reset value
			X	Read out

- Address 0X4C : Bottom 8 bit of C3 level meter

BIT	NAME	DESCRIPTION	VALUE	FUNCTION
B[7:0]	C3_LEVEL_B	Bottom 8 bits of channel 3 level meter	0000000	Reset value
			X	Read out

- Address 0X4D : Top 8 bit of C4 level meter

In one/two bands DRC, channel-4 level meter is no use.

In three bands DRC, channel-4 level meter is low frequency path of R channel.

The addresses to show channel-4 level meter are 0X4D, 0X4E, and 0X4F.

BIT	NAME	DESCRIPTION	VALUE	FUNCTION
B[7:0]	C4_LEVEL_T	Top 8 bits of channel 4 level meter	0000000	Reset value
			X	Read out

- Address 0X4E : Middle 8 bit of C4 level meter

BIT	NAME	DESCRIPTION	VALUE	FUNCTION
B[7:0]	C4_LEVEL_M	Middle 8 bits of channel 4 level meter	0000000	Reset value
			X	Read out

- Address 0X4F : Bottom 8 bit of C4 level meter

BIT	NAME	DESCRIPTION	VALUE	FUNCTION
B[7:0]	C4_LEVEL_B	Bottom 8 bits of channel 4 level meter	0000000	Reset value
			X	Read out

- Address 0X50 : Top 8 bit of C5 level meter

In one band DRC, channel-5 level meter is no use.

In two/three bands DRC, channel-5 level meter is band pass frequency path of L channel.

The addresses to show channel-5 level meter are 0X50, 0X51, and 0X52.

BIT	NAME	DESCRIPTION	VALUE	FUNCTION
B[7:0]	C5_LEVEL_T	Top 8 bits of channel 5 level meter	0000000	Reset value
			X	Read out

- Address 0X51 : Middle 8 bit of C5 level meter

BIT	NAME	DESCRIPTION	VALUE	FUNCTION
B[7:0]	C5_LEVEL_M	Middle 8 bits of channel 5 level meter	0000000	Reset value
			X	Read out

- Address 0X52 : Bottom 8 bit of C5 level meter

BIT	NAME	DESCRIPTION	VALUE	FUNCTION
B[7:0]	C5_LEVEL_B	Bottom 8 bits of channel 5 level meter	0000000	Reset value
			X	Read out

- Address 0X53 : Top 8 bit of C6 level meter

In one band DRC, channel-6 level meter is no use.

In two/three bands DRC, channel-6 level meter is band pass frequency path of R channel.

The addresses to show channel-6 level meter are 0X53, 0X54, and 0X55.

BIT	NAME	DESCRIPTION	VALUE	FUNCTION
B[7:0]	C6_LEVEL_T	Top 8 bits of channel 6 level meter	0000000	Reset value
			X	Read out

- Address 0X54 : Middle 8 bit of C6 level meter

BIT	NAME	DESCRIPTION	VALUE	FUNCTION
B[7:0]	C6_LEVEL_M	Middle 8 bits of channel 6 level meter	0000000	Reset value
			X	Read out

- Address 0X55 : Bottom 8 bit of C6 level meter

BIT	NAME	DESCRIPTION	VALUE	FUNCTION
B[7:0]	C6_LEVEL_B	Bottom 8 bits of channel 6 level meter	0000000	Reset value
			X	Read out

- Address 0X56 : Top 8 bit of C7 level meter

In one band DRC, channel-7 level meter is no use.

In two/three bands DRC, channel-7 level meter is summation path of L channel.

The addresses to show channel-7 level meter are 0X56, 0X57, and 0X58.

BIT	NAME	DESCRIPTION	VALUE	FUNCTION
B[7:0]	C7_LEVEL_T	Top 8 bits of channel 7 level meter	0000000	Reset value
			X	Read out

- Address 0X57 : Middle 8 bit of C7 level meter

BIT	NAME	DESCRIPTION	VALUE	FUNCTION
B[7:0]	C7_LEVEL_M	Middle 8 bits of channel 7 level meter	0000000	Reset value
			X	Read out

- Address 0X58 : Bottom 8 bit of C7 level meter

BIT	NAME	DESCRIPTION	VALUE	FUNCTION
B[7:0]	C7_LEVEL_B	Bottom 8 bits of channel 7 level meter	0000000	Reset value
			X	Read out

- Address 0X59 : Top 8 bit of C8 level meter

In one band DRC, channel-8 level meter is no use.

In two/three bands DRC, channel-8 level meter is summation path of L channel.

The addresses to show channel-8 level meter are 0X59, 0X5A, and 0X5B.

BIT	NAME	DESCRIPTION	VALUE	FUNCTION
B[7:0]	C8_LEVEL_T	Top 8 bits of channel 8 level meter	0000000	Reset value
			X	Read out

- Address 0X5A : Middle 8 bit of C8 level meter

BIT	NAME	DESCRIPTION	VALUE	FUNCTION
B[7:0]	C8_LEVEL_M	Middle 8 bits of channel 8 level meter	0000000	Reset value
			X	Read out

- Address 0X5B : Bottom 8 bit of C8 level meter

BIT	NAME	DESCRIPTION	VALUE	FUNCTION
B[7:0]	C8_LEVEL_B	Bottom 8 bits of channel 8 level meter	0000000	Reset value
			X	Read out

● Address 0X5C : I2S output selection

AD82584F provide I2S output function and the output point can be selected via bit 2~bit 0.

BIT	NAME	DESCRIPTION	VALUE	FUNCTION
B[7:3]		Reserved		
B[2:0]	I2S_DO_SEL	I2S DATA OUTPUT selection	000	DSP input (Point1)
			001	Pre-scale output (Point2)
			010	Mixer output (Point3)
			011	EQ12 output (Point4)
			100	Volume output (Point5)
			101	Clipping output (Point6)
			110	DC blocking HPF output (Point7)
			111	Reserved

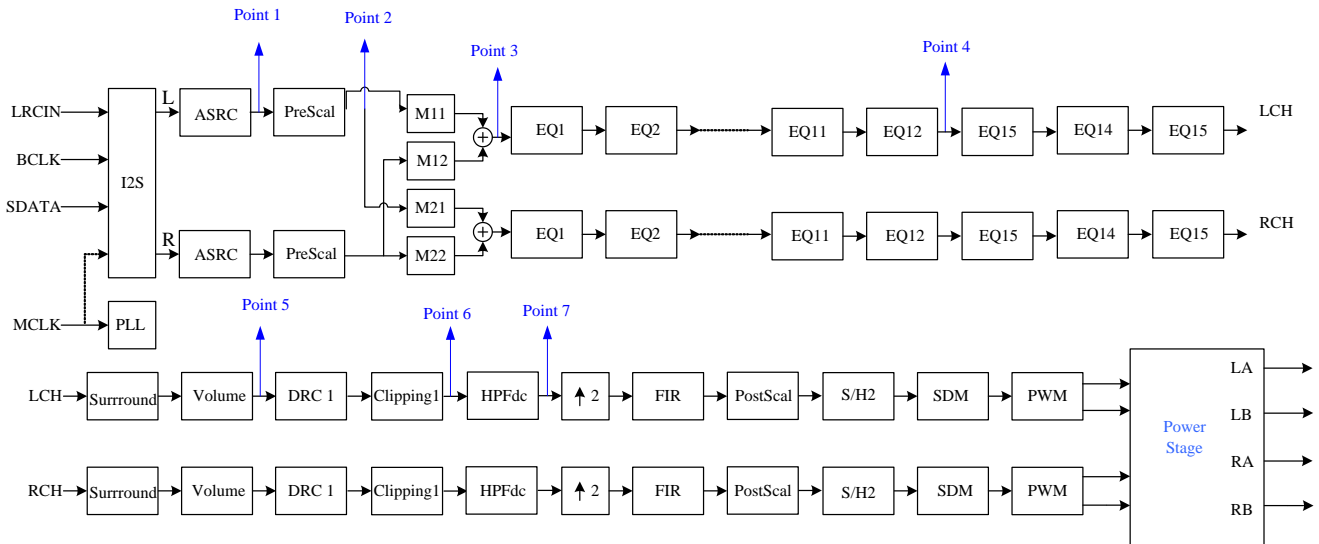

- Address 0X74 : MONO_KEY high byte

AD82584F doesn't have PBTL pin in TSSOP 24 package option. It can set MONO_EN=1 & MONO_KEY=3006 (hex) to configure MONO type.

BIT	NAME	DESCRIPTION	VALUE	FUNCTION
B[7:0]	MK_HBYTE	MONO KEY high byte	others	Stereo
			00110000	Mono

- Address 0X75 : MONO_KEY low byte

BIT	NAME	DESCRIPTION	VALUE	FUNCTION
B[7:0]	MK_LBYTE	MONO KEY low byte	others	Stereo
			00000110	Mono

- Address 0X84 : Protection register

The protection registers will show what kind of protection occurs.

BIT	NAME	DESCRIPTION	VALUE	FUNCTION
B[7]	A_OCP_N	OCP register	0	OC occur
			1	Normal
B[6]	A_OTP_N	OTP register	0	OT occur
			1	Normal
B[5]	A_UV_N	UV register	0	UV occur
			1	Normal
B[4]	A_BSUV	BSUV register	0	BSUV occur
			1	Normal
B[3]	A_BSOV	BSOV register	0	BSOV occur
			1	Normal
B[2]	A_CKERR	CKERR register	0	CKERR occur
			1	Normal
B[1]	A_OVP	OVP register	0	OV occur
			1	Normal

- Address 0X85 : Protection latch register

The protection registers will show what kind of protection ever occurred.

BIT	NAME	DESCRIPTION	VALUE	FUNCTION
B[7]	A_OCP_N_LATCH	OCP latch register	0	OC ever occur
			1	Normal
B[6]	A_OTP_N_LATCH	OTP latch register	0	OT ever occur
			1	Normal
B[5]	A_UV_N_LATCH	UV latch register	0	UV ever occur
			1	Normal
B[4]	A_BSUV_LATCH	BSUV latch register	0	BSUV ever occur
			1	Normal
B[3]	A_BSOV_LATCH	BSOV latch register	0	BSOV ever occur
			1	Normal
B[2]	A_CKERR_LATCH	CKERR latch register	0	CKERR ever occur
			1	Normal
B[1]	A_OVP_LATCH	OVP latch register	0	OV ever occur
			1	Normal

- Address 0X86 : Protection latch register

The protection latch registers will show what kind of protection ever occurred.

Using the protection clear registers can clear the corresponding protection latch registers.

BIT	NAME	DESCRIPTION	VALUE	FUNCTION
B[7]	A_OCP_N_CLEAR	OCP latch clear register	0	No clear
			1	Clear
B[6]	A_OTP_N_CLEAR	OTP latch clear register	0	No clear
			1	Clear
B[5]	A_UV_N_CLEAR	UV latch clear register	0	No clear
			1	Clear
B[4]	A_BSUV_CLEAR	BSUV latch clear register	0	No clear
			1	Clear
B[3]	A_BSOV_CLEAR	BSOV latch clear register	0	No clear
			1	Clear
B[2]	A_CKERR_CLEAR	CKERR latch clear register	0	No clear
			1	Clear
B[1]	A_OVP_CLEAR	OVP latch clear register	0	No clear
			1	Clear

RAM access

The procedure to read/write coefficient(s) from/to RAM is as followings:

Read a single coefficient from RAM:

1. Write 7-bis of address to I2C address-0X1D
2. Write 1 to R1 bit and write 1/0 to RBS in address-0X2D
3. Read top 8-bits of coefficient in I2C address-0X1E
4. Read middle 8-bits of coefficient in I2C address-0X1F
5. Read bottom 8-bits of coefficient in I2C address-0X20

Read a set of coefficients from RAM:

1. Write 7-bits of address to I2C address-0X1D
2. Write 1 to RA bit and write 1/0 to RBS in address-0X2D
3. Read top 8-bits of coefficient A1 in I2C address-0X1E
4. Read middle 8-bits of coefficient A1 in I2C address-0X1F
5. Read bottom 8-bits of coefficient A1 in I2C address-0X20
6. Read top 8-bits of coefficient A2 in I2C address-0X21
7. Read middle 8-bits of coefficient A2 in I2C address-0X22
8. Read bottom 8-bits of coefficient A2 in I2C address-0X23
9. Read top 8-bits of coefficient B1 in I2C address-0X24
10. Read middle 8-bits of coefficient B1 in I2C address-0X25
11. Read bottom 8-bits of coefficient B1 in I2C address-0X26
12. Read top 8-bits of coefficient B2 in I2C address-0X27
13. Read middle 8-bits of coefficient B2 in I2C address-0X28
14. Read bottom 8-bits of coefficient B2 in I2C address-0X29
15. Read top 8-bits of coefficient A0 in I2C address-0X2A
16. Read middle 8-bits of coefficient A0 in I2C address-0X2B
17. Read bottom 8-bits of coefficient A0 in I2C address-0X2C

Write a single coefficient from RAM:

1. Write 7-bits of address to I2C address-0X1D
2. Write top 8-bits of coefficient in I2C address-0X1E
3. Write middle 8-bits of coefficient in I2C address-0X1F
4. Write bottom 8-bits of coefficient in I2C address-0X20
5. Write 1 to W1 bit and write 1/0 to RBS in address-0X2D

Write a set of coefficients from RAM:

1. Write 7-bits of address to I2C address-0X1D
2. Write top 8-bits of coefficient A1 in I2C address-0X1E
3. Write middle 8-bits of coefficient A1 in I2C address-0X1F
4. Write bottom 8-bits of coefficient A1 in I2C address-0X20
5. Write top 8-bits of coefficient A2 in I2C address-0X21
6. Write middle 8-bits of coefficient A2 in I2C address-0X22
7. Write bottom 8-bits of coefficient A2 in I2C address-0X23
8. Write top 8-bits of coefficient B1 in I2C address-0X24
9. Write middle 8-bits of coefficient B1 in I2C address-0X25
10. Write bottom 8-bits of coefficient B1 in I2C address-0X26
11. Write top 8-bits of coefficient B2 in I2C address-0X27
12. Write middle 8-bits of coefficient B2 in I2C address-0X28
13. Write bottom 8-bits of coefficient B2 in I2C address-0X29
14. Write top 8-bits of coefficient A0 in I2C address-0X2A
15. Write middle 8-bits of coefficient A0 in I2C address-0X2B
16. Write bottom 8-bits of coefficient A0 in I2C address-0X2C
17. Write 1 to WA bit and write 1/0 to RBS in address-0X2D

Note that: the read and write operation on RAM coefficients works only if LRCIN (pin-15) switching on rising edge. And, before each writing operation, it is necessary to read the address-0X24 to confirm whether RAM is writable current in first. If the logic of W1 or WA is high, the coefficient writing is prohibited.

- User-defined equalizer

The AD82584F provides 30 parametric Equalizer (EQ). User can program suitable coefficients via I²C control interface to program the required audio band frequency response for every EQ. The transfer function

$$H(z) = \frac{A_0 + A_1z^{-1} + A_2z^{-2}}{1 + B_1z^{-1} + B_2z^{-2}}$$

The data format of 2's complement binary code for EQ coefficient is 3.21. i.e., 3-bits for integer (MSB is the sign bit) and 21-bits for mantissa. Each coefficient range is from 0x800000 (-4) to 0x7FFFFFFF (+3.999999523). These coefficients are stored in User Defined RAM and are referenced in following manner:

$$\begin{aligned}CHxEQyA0 &= A0 \\CHxEQyA1 &= A1 \\CHxEQyA2 &= A2 \\CHxEQyB1 &= -B1 \\CHxEQyB2 &= -B2\end{aligned}$$

Where x and y represents the number of channel and the band number of EQ biquard.

All user-defined filters are path-through, where all coefficients are defaulted to 0 after being powered up, except the A0 that is set to 0x200000 which represents 1.

- EQ arrangement

AD82584F provide 15 EQ per channel.

When, register with address-0X0C, bit-5, DEQE is set to high, the EQ-7, EQ-8, EQ9, and EQ10 will use another filter coefficient stored in used defined RAM 0X68~0X7B.

When, register with address-0X0C, bit-6, BTE is set to high, the EQ-11 and EQ-12 will perform as bass and treble respectively.

When three bands DRC enable, EQ-13, EQ-14, and EQ-15 will perform as APF, LPF, and HPF respectively.

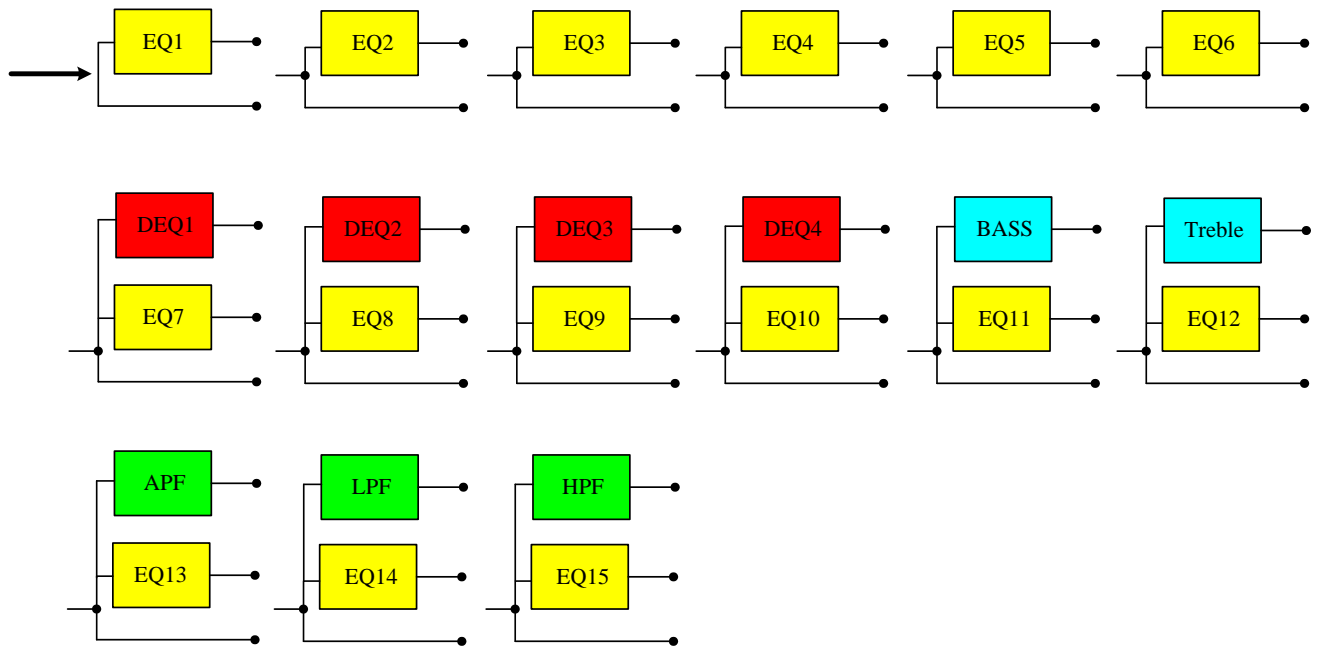

● Mixer

The AD82584F provides mixers to generate the extra audio source from the input left and right channels. The coefficients of mixers are defined in range from 0x800000 (-1) to 0x7FFFFFFF (0.9999998808). The function block diagram is as following:

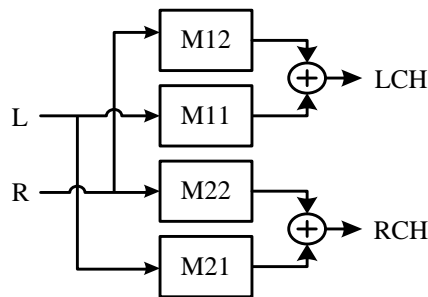

- **Pre-scale**

For each audio channel, AD82584F can scale input signal level prior to EQ processing which is realized by a 24-bit signed fractional multiplier. The pre-scale factor, ranging from -1 (0x800000) to 0.9999998808 (0x7FFFFFFF), for this multiplier, can be loaded into RAM. The default values of the pre-scaling factors are set to 0x7FFFFFFF. Programming of RAM is described in RAM access.

- **Post-scale**

The AD82584F provides an additional multiplication after equalizing and before interpolation stage, which is realized by a 24-bit signed fractional multiplier. The post-scaling factor, ranging from -1 (0x800000) to 0.9999998808 (0x7FFFFFFF), for this multiplier, can be loaded into RAM. The default values of the post-scaling factors are set to 0x7FFFFFFF. All channels can use the channel-1 post-scale factor by setting the post-scale link. Programming of RAM is described in RAM access.

- **Power Clipping**

The AD82584F provides power clipping function to avoid excessive signal that may destroy loud speaker. 3. The power clipping level is defined by 24-bit representation and is stored in RAM address 0X55 of RAM bank 0. The following table shows the power clipping level's numerical representation.

Sample calculation for power clipping

Max amplitude	dB	Linear	Decimal	Hex (3.21 format)
PVDD	0	1	2097152	200000
PVDD*0.707	-3	0.707	1482686	169FBE
PVDD*0.5	-6	0.5	1048576	100000
PVDD*L	x	$L=10^{(x/20)}$	$D=2097152xL$	$H=dec2hex(D)$

- **Attack threshold**

The AD82584F provides DRC function. When the input RMS exceeds the programmable attack threshold value, the output power will be limited by this threshold power level via gradual gain reduction. Four sets of DRC are provided. DRC1 is used for high frequency path in three bands DRC and used for L/R channel in one band DRC. DRC2 is used for low frequency path in three bands DRC. DRC3 is used for band pass frequency path in three bands DRC. DRC4 is used for the post DRC.

Attack threshold is defined by 24-bit presentation and is stored in RAM address 0X56, 0X58, 0X5A, 0X5C of RAM bank 0.

● Release threshold

After AD82584F has reached the attack threshold, its output power will be limited to that level. The output power level will be gradually adjusted to the programmable release threshold level. Release threshold is defined by 24-bit representation and is stored in RAM address 0X57, 0X59, 0X5B, and 0X5D of RAM bank 0. The following table shows the attack and release threshold’s numerical representation.

Sample calculation for attack and release threshold

Power	dB	Linear	Decimal	Hex (3.21 format)
$(PVDD^2)/R$	0	1	2097152	200000
$(PVDD^2)/2R$	-3	0.5	1048576	100000
$(PVDD^2)/4R$	-6	0.25	524288	80000
$((PVDD^2)/R)*L$	x	$L=10^{(x/10)}$	$D=2097152xL$	$H=dec2hex(D)$

To best illustrate the power limit function, please refer to the following figure.

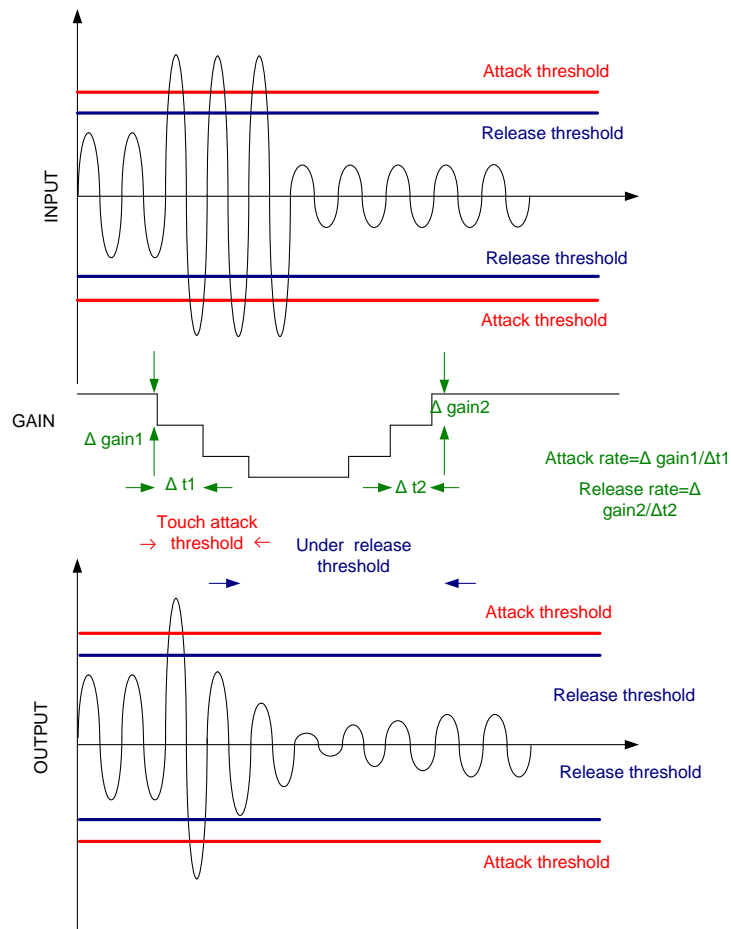

● **Noise Gate Attack Level**

When both left and right signals have 2048 consecutive sample points less than the programmable noise gate attack level, the audio signal will multiply noise gate gain, which can be set at x1/8, x1/4, x1/2, or zero if the noise gate function is enabled. Noise gate attack level is defined by 24-bit representation and is stored in RAM address 0X5E of RAM bank 0.

● **Noise Gate Release Level**

After entering the noise gating status, the noise gain will be removed whenever AD82584F receives any input signal that is more than the noise gate release level. Noise gate release level is defined by 24-bit representation and is stored in RAM address 0X5F of RAM bank 0. The following table shows the noise gate attack and release threshold level's numerical representation.

Sample calculation for noise gate attack and release level

Input amplitude (dB)	Linear	Decimal	Hex (1.23 format)
0	1	8388607	7FFFFFF
-100	10^{-5}	83	53
-110	$10^{-5.5}$	26	1A
x	$L=10^{(x/20)}$	$D=8388607 \times L$	$H=\text{dec2hex}(D)$

● **DRC Energy Coefficient**

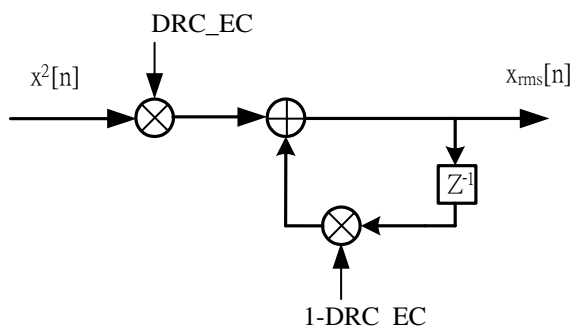

The above figure illustrates the digital processing of calculating RMS signal power. In this processing, a DRC energy coefficient is required, which can be programmed for different frequency range. Four sets of energy coefficients are provided and used for respective DRC. Energy coefficient is defined by 24-bit representation and is stored in RAM address 0X60, 0X61, 0X62, and 0X63 of RAM bank 0. The following table shows the DRC energy coefficient numerical representation.

Sample calculation for DRC energy coefficient

DRC energy coefficient	dB	Linear	Decimal	Hex (1.23 format)
1	0	1	8388607	7FFFFFF
1/256	-48.2	1/256	32768	8000
1/1024	-60.2	1/1024	8192	2000
L	x	$L=10^{(x/20)}$	$D=8388607 \times L$	$H=\text{dec2hex}(D)$

The user defined RAM

The contents of user defined RAM is represented in following table.

RAM Bank selection = 0

Address	NAME	Coefficient	Default
0x00	1 st SET Channel-1 EQ1	CH1EQ1A1	0x000000
0x01		CH1EQ1A2	0x000000
0x02		CH1EQ1B1	0x000000
0x03		CH1EQ1B2	0x000000
0x04		CH1EQ1A0	0x200000
0x05	1 st SET Channel-1 EQ2	CH1EQ2A1	0x000000
0x06		CH1EQ2A2	0x000000
0x07		CH1EQ2B1	0x000000
0x08		CH1EQ2B2	0x000000
0x09		CH1EQ2A0	0x200000
0x0A	1 st SET Channel-1 EQ3	CH1EQ3A1	0x000000
0x0B		CH1EQ3A2	0x000000
0x0C		CH1EQ3B1	0x000000
0x0D		CH1EQ3B2	0x000000
0x0E		CH1EQ3A0	0x200000
0x0F	1 st SET Channel-1 EQ4	CH1EQ4A1	0x000000
0x10		CH1EQ4A2	0x000000
0x11		CH1EQ4B1	0x000000
0x12		CH1EQ4B2	0x000000
0x13		CH1EQ4A0	0x200000
0x14	1 st SET Channel-1 EQ5	CH1EQ5A1	0x000000
0x15		CH1EQ5A2	0x000000
0x16		CH1EQ5B1	0x000000
0x17		CH1EQ5B2	0x000000

0x18		CH1EQ5A0	0x200000
0x19	1 st SET Channel-1 EQ6	CH1EQ6A1	0x000000
0x1A		CH1EQ6A2	0x000000
0x1B		CH1EQ6B1	0x000000
0x1C		CH1EQ6B2	0x000000
0x1D		CH1EQ6A0	0x200000
0x1E		1 st SET Channel-1 EQ7	CH1EQ7A1
0x1F	CH1EQ7A2		0x000000
0x20	CH1EQ7B1		0x000000
0x21	CH1EQ7B2		0x000000
0x22	CH1EQ7A0		0x200000
0x23	1 st SET Channel-1 EQ8		CH1EQ8A1
0x24		CH1EQ8A2	0x000000
0x25		CH1EQ8B1	0x000000
0x26		CH1EQ8B2	0x000000
0x27		CH1EQ8A0	0x200000
0x28		1 st SET Channel-1 EQ9	CH1EQ9A1
0x29	CH1EQ9A2		0x000000
0x2A	CH1EQ9B1		0x000000
0x2B	CH1EQ9B2		0x000000
0x2C	CH1EQ9A0		0x200000
0x2D	1 st SET Channel-1 EQ10		CH1EQ10A1
0x2E		CH1EQ10A2	0x000000
0x2F		CH1EQ10B1	0x000000
0x30		CH1EQ10B2	0x000000
0x31		CH1EQ10A0	0x200000
0x32		1 st SET Channel-1 EQ11	CH1EQ11A1
0x33	CH1EQ11A2		0x000000
0x34	CH1EQ11B1		0x000000
0x35	CH1EQ11B2		0x000000
0x36	CH1EQ11A0		0x200000
0x37	1 st SET Channel-1 EQ12		CH1EQ12A1
0x38		CH1EQ12A2	0x000000
0x39		CH1EQ12B1	0x000000
0x3A		CH1EQ12B2	0x000000
0x3B		CH1EQ12A0	0x200000
0x3C		1 st SET	CH1EQ13A1

0x3D	Channel-1 EQ13	CH1EQ13A2	0x000000
0x3E		CH1EQ13B1	0x000000
0x3F		CH1EQ13B2	0x000000
0x40		CH1EQ13A0	0x200000
0x41	1 st SET Channel-1 EQ14	CH1EQ14A1	0x000000
0x42		CH1EQ14A2	0x000000
0x43		CH1EQ14B1	0x000000
0x44		CH1EQ14B2	0x000000
0x45		CH1EQ14A0	0x200000
0x46	1 st SET Channel-1 EQ15	CH1EQ15A1	0x000000
0x47		CH1EQ15A2	0x000000
0x48		CH1EQ15B1	0x000000
0x49		CH1EQ15B2	0x000000
0x4A		CH1EQ15A0	0x200000
0x4B	Channel-1 Mixer1	M11	0x7FFFFFFF
0x4C	Channel-1 Mixer2	M12	0x000000
0x4D	Channel-1 Prescale	C1PRS	0x7FFFFFFF
0x4E	Channel-1 Postscale	C1POS	0x7FFFFFFF
0X4F	A0 of L channel SRS HPF	LSRSH_A0	C7B691
0X50	A1 of L channel SRS HPF	LSRSH_A1	38496E
0X51	B1 of L channel SRS HPF	LSRSH_B1	C46f8
0X52	A0 of L channel SRS LPF	LSRSL_A0	E81B9
0X53	A1 of L channel SRS LPF	LSRSL_A1	F22C12
0X54	B1 of L channel SRS LPF	LSRSL_B1	FCABB
0x55	CH1.2 Power Clipping	PC1	0x200000
0X56	CH1.2 DRC1 Attack threshold	DRC1_ATH	0x200000
0X57	CH1.2 DRC1 Release threshold	DRC1_RTH	0x80000
0X58	CH3.4 DRC2 Attack threshold	DRC2_ATH	0x200000

0x59	CH3.4 DRC2 Release threshold	DRC2_RTH	0x80000
0x5A	CH5.6 DRC3 Attack threshold	DRC3_ATH	0x200000
0x5B	CH5.6 DRC3 Release threshold	DRC3_RTH	0x80000
0x5C	CH7.8 DRC4 Attack threshold	DRC4_ATH	0x200000
0x5D	CH7.8 DRC4 Release threshold	DRC4_RTH	0x80000
0x5E	Noise Gate Attack Level	NGAL	0x00001A
0x5F	Noise Gate Release Level	NGRL	0x000053
0x60	DRC1 Energy Coefficient	DRC1_EC	0x8000
0x61	DRC2 Energy Coefficient	DRC2_EC	0x2000
0x62	DRC3 Energy Coefficient	DRC3_EC	0x8000
0x63	DRC4 Energy Coefficient	DRC4_EC	0x2000
0x64	DRC1 Power Meter	C1_RMS	
0x65	DRC3 Power Meter	C3_RMS	
0x66	DRC5 Power Meter	C5_RMS	
0x67	DRC7 Power Meter	C7_RMS	
0x68	2 nd SET Channel-1 EQ1 (DEQ1)	CH1EQ1A1	0x000000
0x69		CH1EQ1A2	0x000000
0x6A		CH1EQ1B1	0x000000
0x6B		CH1EQ1B2	0x000000
0x6C		CH1EQ1A0	0x200000
0x6D	2 nd SET Channel-1 EQ2 (DEQ2)	CH1EQ2A1	0x000000
0x6E		CH1EQ2A2	0x000000
0x6F		CH1EQ2B1	0x000000
0x70		CH1EQ2B2	0x000000
0x71		CH1EQ2A0	0x200000
0x72	2 nd SET Channel-1 EQ3 (DEQ3)	CH1EQ3A1	0x000000
0x73		CH1EQ3A2	0x000000
0x74		CH1EQ3B1	0x000000
0x75		CH1EQ3B2	0x000000
0x76		CH1EQ3A0	0x200000
0x77	2 nd SET	CH1EQ4A1	0x000000

0x78	Channel-1 EQ4 (DEQ4)	CH1EQ4A2	0x000000
0x79		CH1EQ4B1	0x000000
0x7A		CH1EQ4B2	0x000000
0x7B		CH1EQ4A0	0x200000

RAM Bank selection = 1

Address	NAME	Coefficient	Default
0x00	1 st SET Channel-2 EQ1	CH2EQ1A1	0x000000
0x01		CH2EQ1A2	0x000000
0x02		CH2EQ1B1	0x000000
0x03		CH2EQ1B2	0x000000
0x04		CH2EQ1A0	0x200000
0x05	1 st SET Channel-2 EQ2	CH2EQ2A1	0x000000
0x06		CH2EQ2A2	0x000000
0x07		CH2EQ2B1	0x000000
0x08		CH2EQ2B2	0x000000
0x09		CH2EQ2A0	0x200000
0x0A	1 st SET Channel-2 EQ3	CH2EQ3A1	0x000000
0x0B		CH2EQ3A2	0x000000
0x0C		CH2EQ3B1	0x000000
0x0D		CH2EQ3B2	0x000000
0x0E		CH2EQ3A0	0x200000
0x0F	1 st SET Channel-2 EQ4	CH2EQ4A1	0x000000
0x10		CH2EQ4A2	0x000000
0x11		CH2EQ4B1	0x000000
0x12		CH2EQ4B2	0x000000
0x13		CH2EQ4A0	0x200000
0x14	1 st SET Channel-2 EQ5	CH2EQ5A1	0x000000
0x15		CH2EQ5A2	0x000000
0x16		CH2EQ5B1	0x000000
0x17		CH2EQ5B2	0x000000
0x18		CH2EQ5A0	0x200000
0x19	1 st SET Channel-2 EQ6	CH2EQ6A1	0x000000
0x1A		CH2EQ6A2	0x000000
0x1B		CH2EQ6B1	0x000000
0x1C		CH2EQ6B2	0x000000
0x1D		CH2EQ6A0	0x200000

0x1E	1 st SET Channel-2 EQ7	CH2EQ7A1	0x000000
0x1F		CH2EQ7A2	0x000000
0x20		CH2EQ7B1	0x000000
0x21		CH2EQ7B2	0x000000
0x22		CH2EQ7A0	0x200000
0x23	1 st SET Channel-2 EQ8	CH2EQ8A1	0x000000
0x24		CH2EQ8A2	0x000000
0x25		CH2EQ8B1	0x000000
0x26		CH2EQ8B2	0x000000
0x27		CH2EQ8A0	0x200000
0x28	1 st SET Channel-2 EQ9	CH2EQ9A1	0x000000
0x29		CH2EQ9A2	0x000000
0x2A		CH2EQ9B1	0x000000
0x2B		CH2EQ9B2	0x000000
0x2C		CH2EQ9A0	0x200000
0x2D	1 st SET Channel-2 EQ10	CH2EQ10A1	0x000000
0x2E		CH2EQ10A2	0x000000
0x2F		CH2EQ10B1	0x000000
0x30		CH2EQ10B2	0x000000
0x31		CH2EQ10A0	0x200000
0x32	1 st SET Channel-2 EQ11	CH2EQ11A1	0x000000
0x33		CH2EQ11A2	0x000000
0x34		CH2EQ11B1	0x000000
0x35		CH2EQ11B2	0x000000
0x36		CH2EQ11A0	0x200000
0x37	1 st SET Channel-2 EQ12	CH2EQ12A1	0x000000
0x38		CH2EQ12A2	0x000000
0x39		CH2EQ12B1	0x000000
0x3A		CH2EQ12B2	0x000000
0x3B		CH2EQ12A0	0x200000
0x3C	1 st SET Channel-2 EQ13	CH2EQ13A1	0x000000
0x3D		CH2EQ13A2	0x000000
0x3E		CH2EQ13B1	0x000000
0x3F		CH2EQ13B2	0x000000
0x40		CH2EQ13A0	0x200000
0x41	1 st SET Channel-2 EQ14	CH2EQ14A1	0x000000
0x42		CH2EQ14A2	0x000000

0x43		CH2EQ14B1	0x000000
0x44		CH2EQ14B2	0x000000
0x45		CH2EQ14A0	0x200000
0x46	1 st SET Channel-2 EQ15	CH2EQ15A1	0x000000
0x47		CH2EQ15A2	0x000000
0x48		CH2EQ15B1	0x000000
0x49		CH2EQ15B2	0x000000
0x4A		CH2EQ15A0	0x200000
0x4B	Channel-2 Mixer1	M21	0x000000
0x4C	Channel-2 Mixer2	M22	0x7FFFFFF
0x4D	Channel-2 Prescale	C2PRS	0x7FFFFFF
0x4E	Channel-2 Postscale	C2POS	0x7FFFFFF
0X4F	A0 of R channel SRS HPF	RSRSH_A0	C7B691
0X50	A1 of R channel SRS HPF	RSRSH_A1	38496E
0X51	B1 of R channel SRS HPF	RSRSH_B1	C46f8
0X52	A0 of R channel SRS LPF	RSRSL_A0	E81B9
0X53	A1 of R channel SRS LPF	RSRSL_A1	F22C12
0X54	B1 of R channel SRS LPF	RSRSL_ B1	FCABB
0x55	Reserved		
0X56	Reserved		
0X57	Reserved		
0X58	Reserved		
0X59	Reserved		
0x5A	Reserved		
0x5B	Reserved		
0x5C	Reserved		
0x5D	Reserved		
0x5E	Reserved		
0x5F	Reserved		
0x60	Reserved		
0X61	Reserved		

0x62	Reserved		
0x63	Reserved		
0x64	DRC2 Power Meter	C2_RMS	
0x65	DRC4 Power Meter	C4_RMS	
0x66	DRC6 Power Meter	C6_RMS	
0x67	DRC8 Power Meter	C8_RMS	
0x68	2 nd SET Channel-2 EQ1 (DEQ1)	CH2EQ1A1	0x000000
0x69		CH2EQ1A2	0x000000
0x6A		CH2EQ1B1	0x000000
0x6B		CH2EQ1B2	0x000000
0x6C		CH2EQ1A0	0x200000
0x6D	2 nd SET Channel-2 EQ2 (DEQ2)	CH2EQ2A1	0x000000
0x6E		CH2EQ2A2	0x000000
0x6F		CH2EQ2B1	0x000000
0x70		CH2EQ2B2	0x000000
0x71		CH2EQ2A0	0x200000
0x72	2 nd SET Channel-2 EQ3 (DEQ3)	CH2EQ3A1	0x000000
0x73		CH2EQ3A2	0x000000
0x74		CH2EQ3B1	0x000000
0x75		CH2EQ3B2	0x000000
0x76		CH2EQ3A0	0x200000
0x77	2 nd SET Channel-2 EQ4 (DEQ4)	CH2EQ4A1	0x000000
0x78		CH2EQ4A2	0x000000
0x79		CH2EQ4B1	0x000000
0x7A		CH2EQ4B2	0x000000
0x7B		CH2EQ4A0	0x200000

Package Dimensions

● E-LQFP-48L (7mm x 7mm)

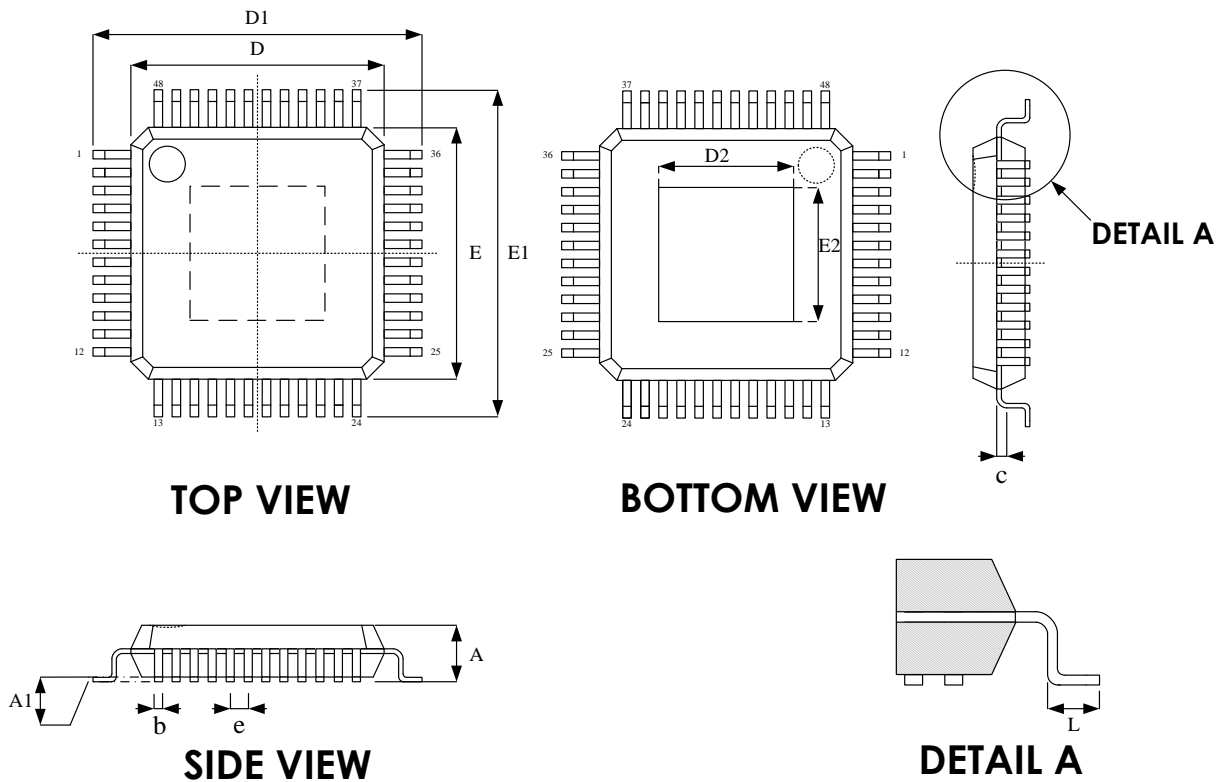

Symbol	Dimension in mm	
	Min	Max
A	--	1.60
A1	0.05	0.15
b	0.17	0.27
c	0.09	0.20
D	6.90	7.10
D1	8.90	9.10
E	6.90	7.10
E1	8.90	9.10
e	0.50 BSC	
L	0.45	0.75

Exposed pad

	Dimension in mm	
	Min	Max
D2	4.31	5.21
E2	4.31	5.21

Package Dimensions

E-TSSOP 24L (173mil)

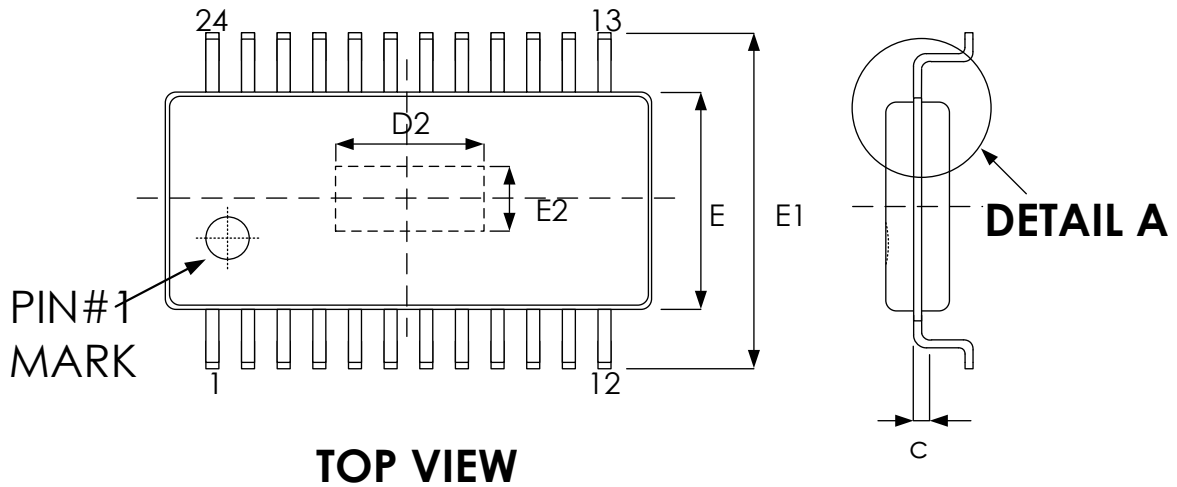

TOP VIEW

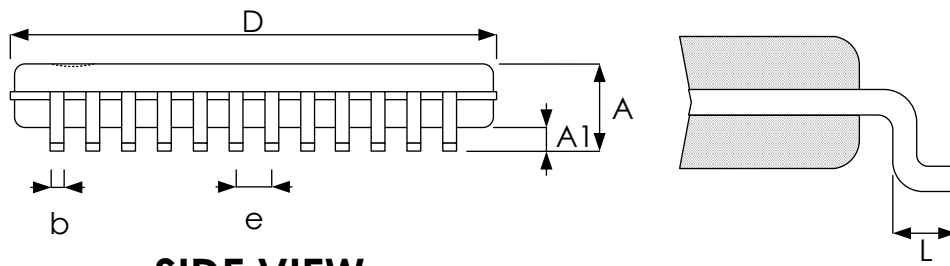

SIDE VIEW

Symbol	Dimension in mm	
	Min	Max
A	1.00	1.20
A1	0.00	0.15
b	0.19	0.30
c	0.09	0.20
D	7.70	7.90
E	4.30	4.50
E1	6.30	6.50
e	0.65 BSC	
L	0.45	0.75

Exposed pad

	Dimension in mm	
	Min	Max
D2	3.95	4.75
E2	2.70	3.10

Revision History

Revision	Date	Description
0.1	2017.10.12	Original.
1.0	2017.12.08	Remove "Preliminary" & modify 0X5C default define.
1.1	2017.12.22	New add tape reel order information.
1.2	2018.01.16	New add description of ESD in Absolute Maximum Ratings.
1.3	2018.02.13	1) Add symbol of $R_{DS(ON)}$ in General Electrical Characteristics. 2) Remove bead in Application Circuit Example for Mono.
1.4	2018.05.25	1) Add output pin to GND AMR voltage. 2) Update application circuit for Stereo. 3) Add Po vs. Supply voltage curve. 4) Update Power on sequence. 5) Update The user defined RAM.
1.5	2018.07.27	1) Add Package Type of E-TSSOP 28L. 2) Modify Pin Description of BCLK. 3) Update Detail Description for Address 0X01.
1.6	2019.03.29	1) Add 4ohm BTL Performance Data. 2) Update Po vs. Supply voltage curve. 3) Update package outline drawing of TSSOP-24 and TSSOP-28.
1.7	2019.05.28	1) Modify Max Value of $I_Q(LV)$ in General Electrical Characteristics. 2) Modify Default Value of Address 0X1B B[7].
1.8	2019.06.24	1) Update Power On Sequence. 2) Update The Table of Address 0x1B.
1.9	2019.09.17	1) Modify Minimum Value of Junction Operating Temperature in Absolute Maximum Ratings (AMR). 2) Modify Default Value of Channel-2 Postscale.
2.0	2019.11.13	1) Modify CHARACTERISTICS of PBTL, MCLK, BCLK and LRCIN. 2) Modify the Formula of Tfade-in / Tfade-out.
2.1	2020.01.03	1) Modify Illustration of System Clock Timing. 2) Modify Illustration of Mixer.
2.2	2020.05.04	Modify Power on Sequence.
2.3	2020.07.01	1) Add 01-E-LQPF-48 Pin Assignment, Pin Description, Ordering Information and Marking Information 2) Remove TSSOP-28E package option
2.4	2020.07.14	Add by request wording for 01-E-LQPF-48
2.5	2021.05.24	Modify Power on Sequence.

2.6	2021.08.19	Modify E-TSSOP 24L (173mil) package Dimensions D2 min value
-----	------------	--

Important Notice

All rights reserved.

No part of this document may be reproduced or duplicated in any form or by any means without the prior permission of ESMT.

The contents contained in this document are believed to be accurate at the time of publication. ESMT assumes no responsibility for any error in this document, and reserves the right to change the products or specification in this document without notice.

The information contained herein is presented only as a guide or examples for the application of our products. No responsibility is assumed by ESMT for any infringement of patents, copyrights, or other intellectual property rights of third parties which may result from its use. No license, either express, implied or otherwise, is granted under any patents, copyrights or other intellectual property rights of ESMT or others.

Any semiconductor devices may have inherently a certain rate of failure. To minimize risks associated with customer's application, adequate design and operating safeguards against injury, damage, or loss from such failure, should be provided by the customer when making application designs.

ESMT's products are not authorized for use in critical applications such as, but not limited to, life support devices or system, where failure or abnormal operation may directly affect human lives or cause physical injury or property damage. If products described here are to be used for such kinds of application, purchaser must do its own quality assurance testing appropriate to such applications.