

## 2x15W Stereo Class-D Audio Amplifier with Power Limit

### Features

- Single supply voltage  
4.5V ~ 14.4V for loudspeaker driver  
Built-in LDO output 5V for others
- Loudspeaker power from 12V supply  
BTL Mode: 8W/CH into 8Ω @1% THD+N  
BTL Mode: 10W/CH into 6Ω @<1% THD+N  
BTL Mode: 12W/CH into 4Ω @<1% THD+N  
PBTL Mode: 16W/CH into 4Ω @1% THD+N
- Loudspeaker power from 12V supply  
BTL Mode: 10W/CH into 8Ω @10% THD+N  
BTL Mode: 14W/CH into 6Ω @10% THD+N  
BTL Mode: 15W/CH into 4Ω @<10% THD+N  
PBTL Mode: 20W/CH into 4Ω @10% THD+N
- 93% efficient Class-D operation eliminates need for heat sink
- Differential inputs
- Internal oscillator
- Short-Circuit protection with auto recovery option
- Under-Voltage detection
- Over-Voltage protection
- Pop noise and click noise reduction
- Adjustable power limit function for speaker protection
- Output DC detection for speaker protection
- Filter-Free operation
- Over temperature protection with auto recovery
- Superior EMC performance

### Applications

- TV audio
- Boom-Box
- Powered speaker
- Monitors
- Consumer Audio Equipment

### Description

The AD52058C is a high efficiency stereo class-D audio amplifier with adjustable power limit function. The loudspeaker driver operates from 4.5V~14.4V supply voltage. It can deliver 15W/CH output power into 4Ω loudspeaker within 10% THD+N at 12V supply voltage and without external heat sink when playing music.

The adjustable power limit function allows user to set a voltage rail lower than half of 5V to limit the amount of current through the speaker.

Output DC detection prevents speaker damage from long-time current stress. AD52058C provides superior EMC performance for filter-free application. The output short circuit and over temperature protection include auto-recovery feature.

### Simplified Application Circuit

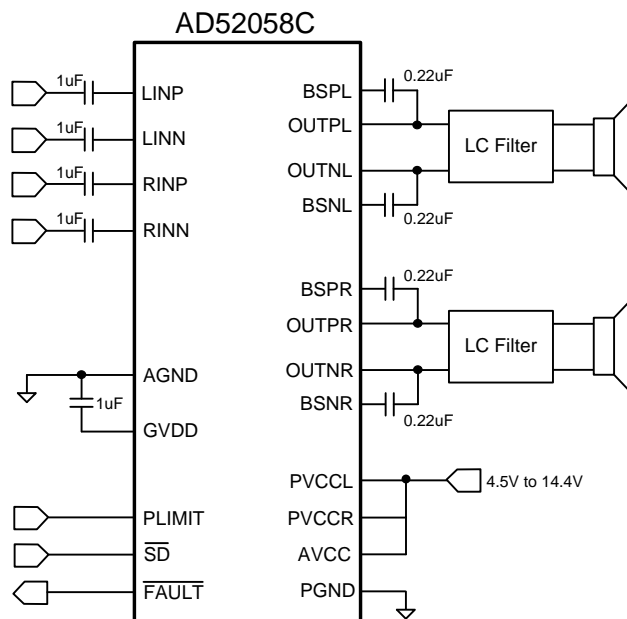

## Pin Assignments

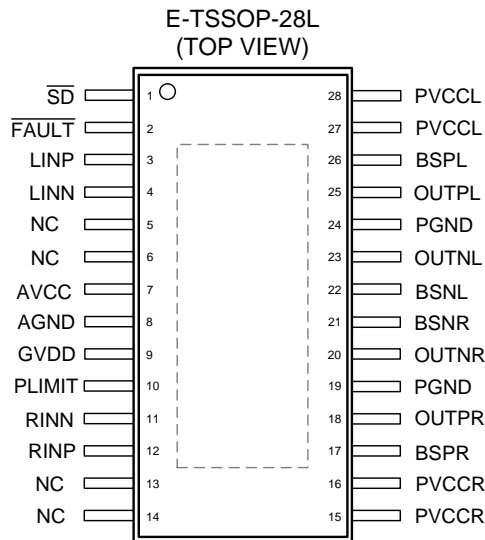

## Pin Description

NAME	E-TSSOP-28L	TYP	DESCRIPTION
$\overline{SD}$	1	I	Shutdown signal for IC (low = disabled, high = operational). Voltage compliance to AVCC. This pin is with pull low 210kohm internally.
$\overline{FAULT}$	2	O	Open drain output used to display short circuit or dc detect fault. Voltage compliant to AVCC. Short circuit faults can be set to auto-recovery by connecting FAULTB pin to $\overline{SD}$ pin. Otherwise, both short circuit faults and dc detect faults must be reset by cycling AVCC.
LINP	3	I	Positive audio input for left channel.
LINN	4	I	Negative audio input for left channel.
NC	5	NA	NC pin.
NC	6	NA	NC pin.
AVCC	7	P	Analog supply.
AGND	8	P	Analog signal ground. Connect to the thermal pad.
GVDD	9	O	5V regulated output, also used as supply for PLIMIT function.
PLIMIT	10	I	Power limit level adjustment. Connect a resistor divider from GVDD to GND to set power limit. Give $V_{PLIMIT}$ 0.3~2.7V to set power limit level. Connect to GVDD (>3V) or GND (<0.26V) to disable power limit function.
RINN	11	I	Negative audio input for right channel.
RINP	12	I	Positive audio input for right channel.
NC	13	NA	NC pin.
NC	14	NA	NC pin.
PVCCR	15,16	P	High-voltage power supply for right-channel. Right channel and left channel power supply inputs are connect internal.

BSPR	17	I	Bootstrap I/O for right channel, positive high side FET.
OUTPR	18	O	Class-D H-bridge positive output for right channel.
PGND	19	P	Power ground for the H-bridges.
OUTNR	20	O	Class-D H-bridge negative output for right channel.
BSNR	21	I	Bootstrap I/O for right channel, negative high side FET.
BSNL	22	I	Bootstrap I/O for left channel, negative high side FET.
OUTNL	23	O	Class-D H-bridge negative output for left channel.
PGND	24	P	Power ground for the H-bridges.
OUTPL	25	O	Class-D H-bridge positive output for left channel.
BSPL	26	I	Bootstrap I/O for left channel, positive high side FET.
PVCCL	27,28	P	High-voltage power supply for right-channel. Right channel and left channel power supply inputs are connect internal.
Thermal Pad		P	Must be soldered to PCB's ground plane.

## Ordering Information

Product ID	Package	Packing / MPQ	Comments
AD52058C-26QG28NRR	E-TSSOP 28L	2500 Units / Reel 1reel/small box	Green

## Available Package

Package Type	Device No.	$\theta_{JA} (^{\circ}C/W)$	$\theta_{JT} (^{\circ}C/W)$	$\Psi_{JT} (^{\circ}C/W)$	Exposed Thermal Pad
E-TSSOP 28L	AD52058C	28	27.1	1.33	Yes (Note 1)

**Note 1.1:** The thermal pad is located at the bottom of the package. To optimize thermal performance, soldering the thermal pad to the PCB's ground plane is necessary.

**Note 1.2:**  $\theta_{JA}$  is simulated on a room temperature ( $T_A=25^{\circ}C$ ), natural convection environment test board, which is constructed with a thermally efficient, 4-layers PCB (2S2P). The measurement is simulated using the JEDEC51-5 thermal measurement standard.

**Note 1.3:**  $\theta_{JT}$  represents the thermal resistance for the heat flow between the chip junction and the package's top surface. It's extracted from the simulation data with obtaining a cold plate on the package top.

**Note 1.4:**  $\Psi_{JT}$  represents the thermal parameter for the heat flow between the chip junction and the package's top surface center. It's extracted from the simulation data for obtaining  $\theta_{JA}$ , using a procedure described in JESD51-5.

## Marking Information

### AD52058C

- Marking Information

Line 1 : LOGO

Line 2 : Product No

Line 3 : Tracking Code

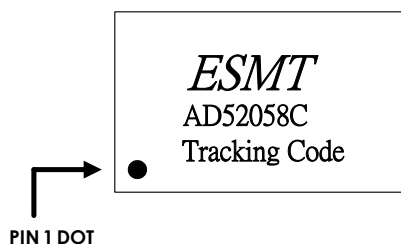

## Absolute Maximum Ratings

Stresses beyond those listed under *absolute maximum ratings* may cause permanent damage to the device.

SYMBOL	PARAMETER	TEST CONDITIONS	MIN	MAX	UNIT
PVCC	Supply voltage	PVCCL, PVCCR	-0.3	20	V
V <sub>I</sub>	Interface pin voltage	$\overline{SD}$ , $\overline{FAULT}$	-0.3	20	V
		PLIMIT	-0.3	5.5	
T <sub>A</sub>	Operating free-air temperature range		-40	85	°C
T <sub>J</sub>	Operating junction temperature range		-40	150	°C
T <sub>stg</sub>	Storage temperature range		-65	150	°C
R <sub>L</sub>	Minimum Load Resistance		3.2		Ω
ESD	Human Body Model			±2K	V
	ChargedDevice Model			±750	

## Recommended Operating Conditions

SYMBOL	PARAMETER	TEST CONDITIONS	MIN	MAX	UNIT
PVCC	Supply voltage	AVCC, PVCCL, PVCCR	4.5	14.4	V
V <sub>I</sub>	Signal input level voltage	LINP, LINN, RINP, RINN		2	V <sub>rms</sub>
V <sub>IH</sub>	High-level input voltage	$\overline{SD}$	2		V
V <sub>IL</sub>	Low-level input voltage	$\overline{SD}$		0.8	V
V <sub>OL</sub>	Low-level output voltage	FAULT, R <sub>PULL-UP</sub> =100k, V <sub>CC</sub> =16V		0.8	V
I <sub>IH</sub>	High-level input current	$\overline{SD}$ , V <sub>I</sub> =2V, V <sub>CC</sub> =12V		50	uA
I <sub>IL</sub>	Low-level input current	$\overline{SD}$ , V <sub>I</sub> =0.8V, V <sub>CC</sub> =12V		5	uA
I <sub>OH</sub>	High-level output current	V <sub>I</sub> =2V, V <sub>CC</sub> =12V		50	uA
I <sub>OL</sub>	Low-level output current	V <sub>I</sub> =0.8V, V <sub>CC</sub> =12V		50	uA
T <sub>A</sub>	Operating free-air		-40	85	°C

## General Electrical Characteristics

- PVCC=12V, R<sub>L</sub>=8Ω, T<sub>A</sub>=25°C (unless otherwise noted)

SYMBOL	PARAMETER	CONDITION	MIN	TYP	MAX	UNIT
I <sub>CC(Q)</sub>	Quiescent supply current	SD=2V, no load, PVCC=12V		8	12	mA
I <sub>CC(SD)</sub>	Quiescent supply current in shutdown mode	SD=0.8V, no load, PVCC=12V		<12	25	uA
R <sub>DS(on)</sub>	Drain-source on-state resistance-High side NMOS	PVCC=12V, I <sub>d</sub> =500mA, T <sub>J</sub> =25 °C		190		mΩ
	Drain-source on-state resistance-Low side NMOS			190		mΩ
V <sub>OS</sub>	Class-D output offset voltage (measured differential)	PVCC=12V V <sub>i</sub> =0V, Gain=26dB		1.5	10	mV
f <sub>OSC</sub>	Oscillator frequency		250	310	370	kHz
t <sub>ON</sub>	Turn-on time	SD=2V		8		ms
t <sub>OFF</sub>	Turn-off time	SD=0.8V		3		us
GVDD	Regulator output	I <sub>GVDD</sub> =0.1mA	4.75	5	5.25	V
G	Gain	PVCC=12V,SD=2V	25	26	27	dB
I <sub>SC</sub>	L(R) Channel Over-Current Protection (Note 2)	PVDD=12V		8		A
	Mono Over-Current Protection (Note 2)	PVDD=12V		15		A
T <sub>SENSOR</sub>	Thermal trip point			160		°C
	Thermal hysteresis			25		°C

Note 2: Loudspeaker over-current protection is only effective when loudspeaker drivers are properly connected with external LC filters. Please refer to the application circuit example for recommended LC filter configuration.

## Electrical Characteristics and Specifications of Loudspeaker Driver(BTL, Stereo)

- PVCC=12V, R<sub>L</sub>=8Ω, T<sub>A</sub>=25°C (unless otherwise noted)

SYMBOL	PARAMETER	CONDITION	MIN	TYP	MAX	UNIT
P <sub>O</sub>	Output power	THD+N=10%, f=1kHz, 8Ω		10		W
		THD+N=10%, f=1kHz, 6Ω		14		
		THD+N<10%, f=1kHz, 4Ω		15		
THD+N	Total harmonic distortion plus noise	PVCC=12V, R <sub>L</sub> =8Ω, f=1kHz, P <sub>O</sub> =5W (half-power)		<0.02		%
		PVCC=12V, R <sub>L</sub> =6Ω, f=1kHz, P <sub>O</sub> =7W (half-power)		<0.02		
		PVCC=12V, R <sub>L</sub> =4Ω, f=1kHz, P <sub>O</sub> =7.5W (half-power)		<0.02		
SNR	Signal to noise ratio	Maximum output at THD+N<1%, f=1kHz, Gain=26dB, a-weighted		94		dB
V <sub>n</sub>	Output integrated noise	F=20Hz ~ 20kHz, Gain=26dB, a-weighted filter, R <sub>L</sub> =8Ω		125		uV
K <sub>SVR</sub>	Power Supply Rejection Ratio	V <sub>ripple</sub> =200mVpp at 1kHz, Gain=26dB, inputs ac-grounded		-67		dB
Crosstalk	Crosstalk	F=1kHz, P <sub>O</sub> =1W, Gain=26dB		-94		dB

## Electrical Characteristics and Specifications of Loudspeaker Driver (PBTL, Mono)

- PVCC=12V, R<sub>L</sub>=4Ω, T<sub>A</sub>=25°C (unless otherwise noted)

SYMBOL	PARAMETER	CONDITION	MIN	TYP	MAX	UNIT
P <sub>O</sub>	Output power	THD+N=1%, f=1kHz, 4Ω		16		W
		THD+N=10%, f=1kHz, 4Ω		20		
THD+N	Total harmonic distortion plus noise	PVCC=12V, R <sub>L</sub> =4Ω, f=1kHz, P <sub>O</sub> =15W		<0.02		%
SNR	Signal to noise ratio	Maximum output at THD+N<1%, f=1kHz, Gain=26dB, a-weighted		95		dB
V <sub>n</sub>	Output integrated noise	F=20Hz ~ 20kHz, Gain=26dB, a-weighted filter, R <sub>L</sub> =8Ω		120		uV
K <sub>SVR</sub>	Power Supply Rejection Ratio	V <sub>ripple</sub> =200mVpp at 1kHz, Gain=26dB, inputs ac-grounded		-66		dB

## Typical Characteristics

● PVCC=12V,  $R_L=8\Omega$ ,  $T_A=25^\circ\text{C}$  (unless otherwise noted)

**THD+N vs. Output Power, 8Ω load (Stereo)**

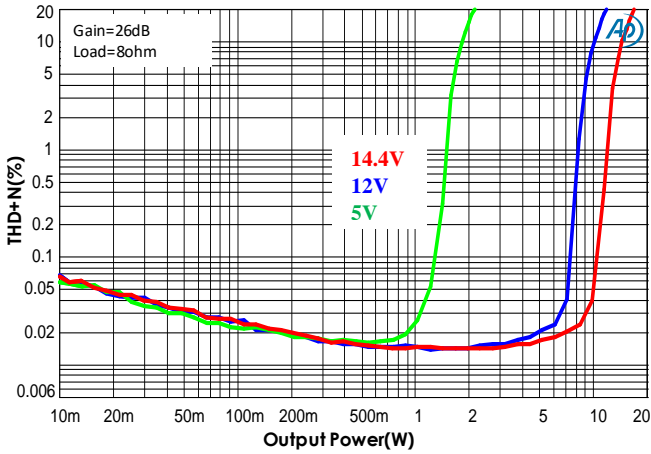

**THD+N vs. Output Power, 4Ω load (Stereo)**

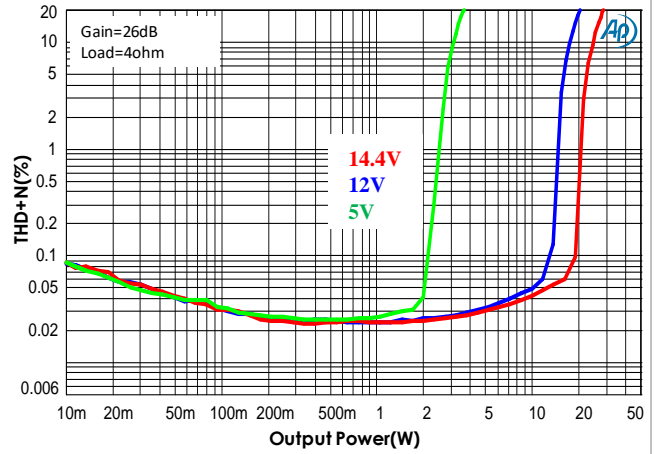

**THD+N vs. Output Power, 6Ω load (Stereo)**

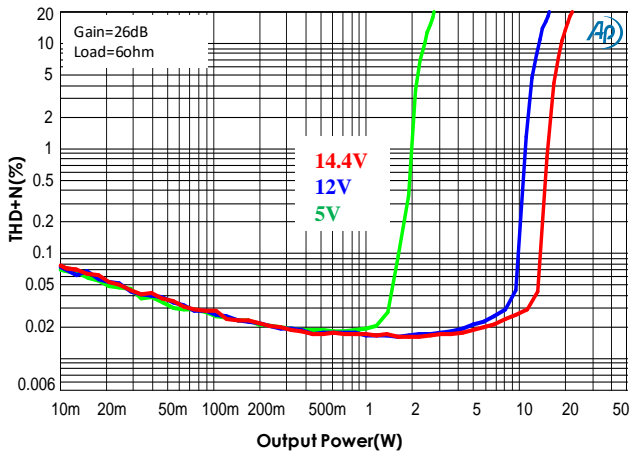

**THD + N (%) vs. Frequency, 8Ω load (Stereo)**

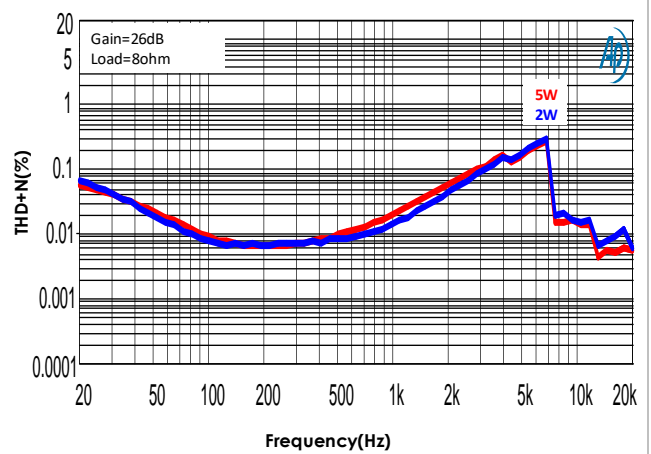

**Noise, 8Ω load (Stereo)**

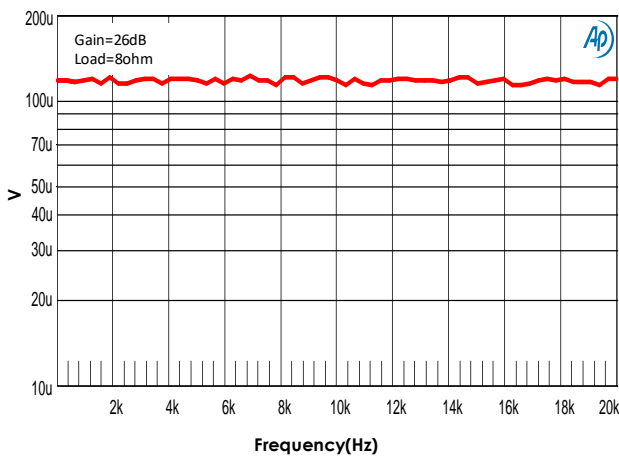

**Efficiency (Stereo 8Ω load) / 2ch**

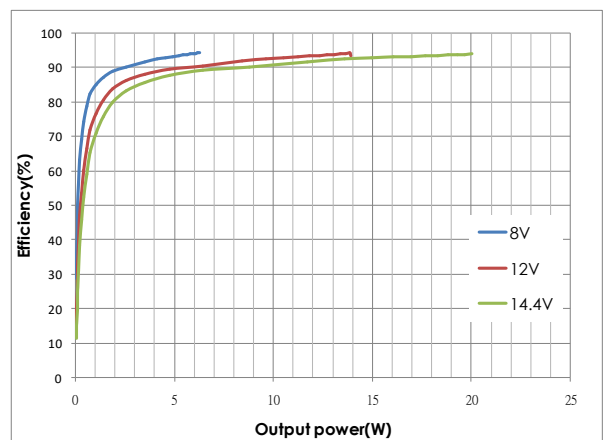

**Cross-Talk ,8Ω load(Stereo)**

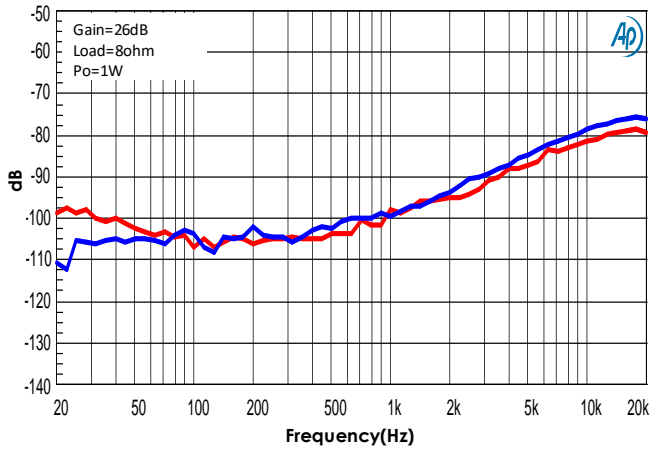

**THD + N (%) vs. Frequency, 4Ω load(Mono)**

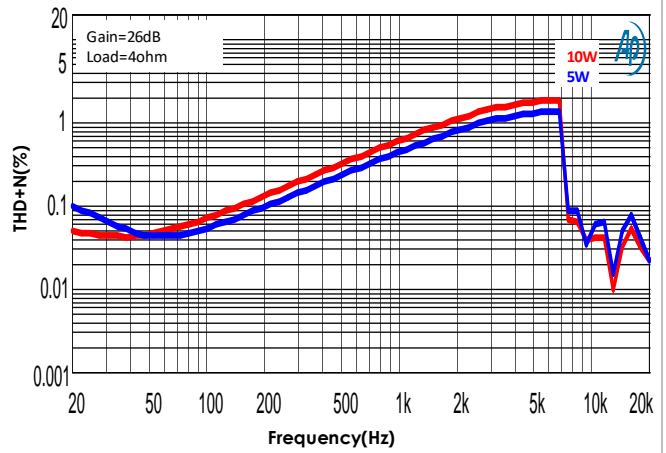

**THD+N vs. Output Power, 4Ω load(Mono)**

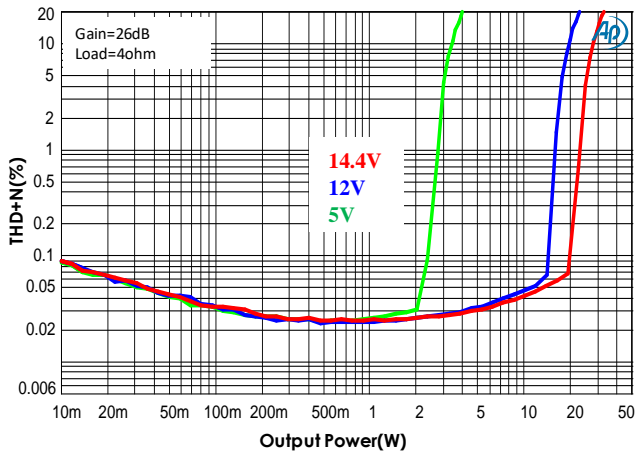

**Efficiency (Mono 4Ω load)**

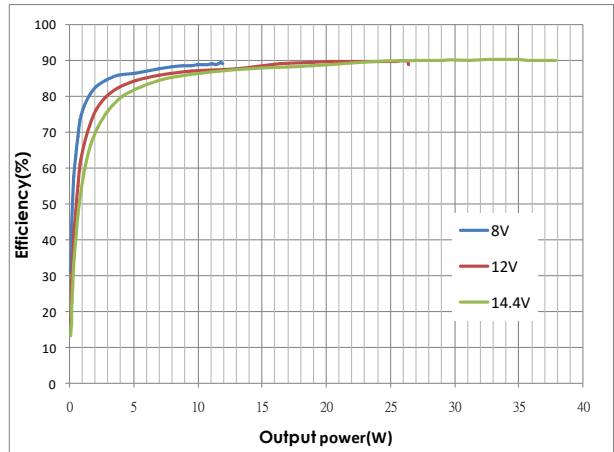

**Supply voltage vs. Output Power, 8Ω load(Stereo)**

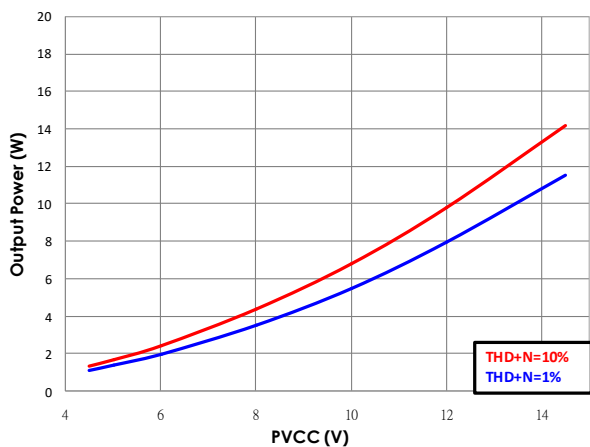

**Supply voltage vs. Output Power, 6Ω load(Stereo)**

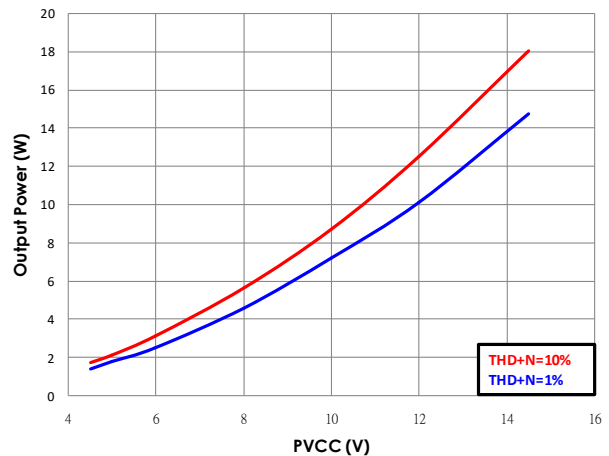



### Supply voltage vs. Output Power, 4Ω load(Stereo)

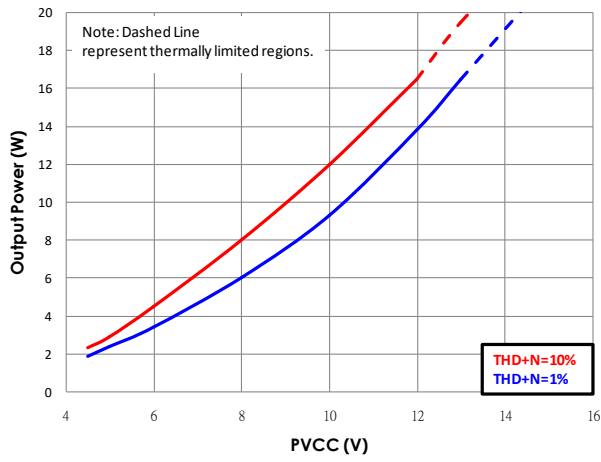

### Supply voltage vs. Output Power, 4Ω load(Mono)

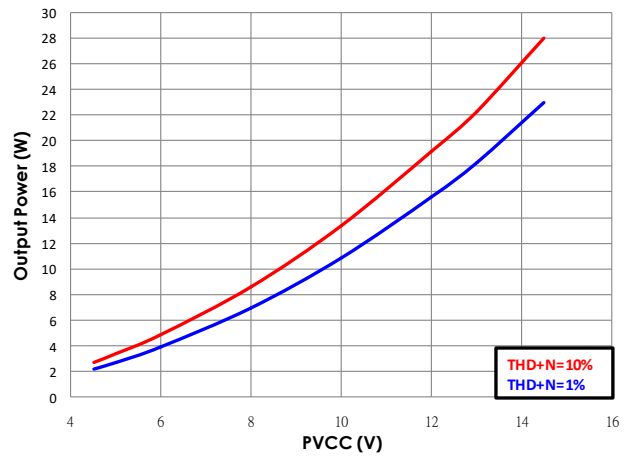

## Functional Block Diagram

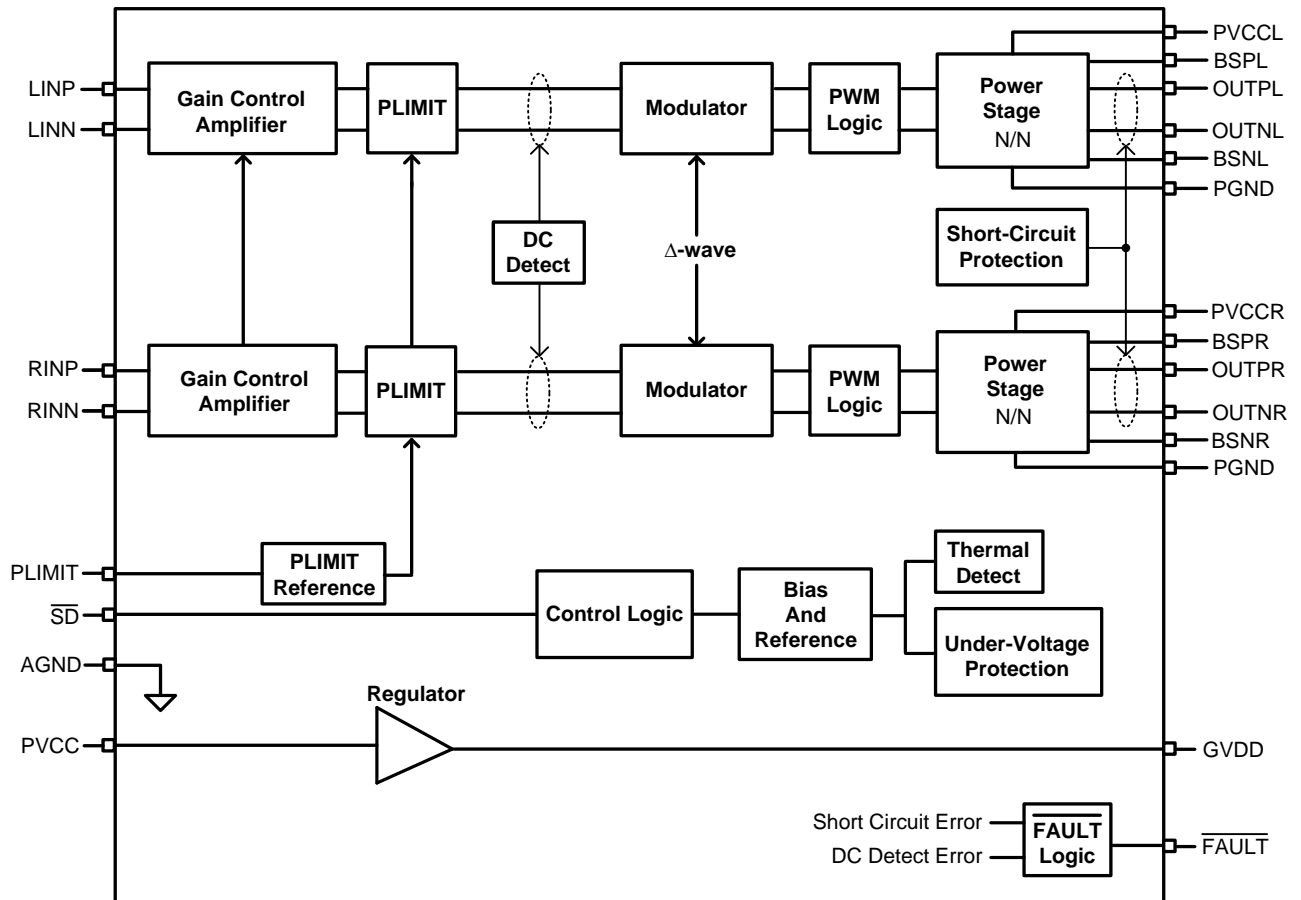

## Operation Descriptions

- **Shutdown ( $\overline{SD}$ ) control**

Pulling  $\overline{SD}$  pin low will let AD52058C operate in low-current state for power conservation. The AD52058C outputs will enter mute once  $\overline{SD}$  pin is pulled low, and regulator will also disable to save power. If let  $\overline{SD}$  pin floating, the chip will enter shutdown mode because of the internal pull low resistor. For the best power-off performance, place the chip in the shutdown mode in advance of removing the power supply.

- **DC detection**

AD52058C has dc detection circuit to protect the speakers from DC current which might be occurred as input capacitor defect or inputs short on printed circuit board. The detection circuit detects first volume amplifier stage output, when both differential outputs' voltage become higher than a determined voltage or lower than a determined voltage for more than 340ms, the dc detect error will occur and report to  $\overline{FAULT}$  pin. At the same time, loudspeaker drivers of right/left channel will disable and enter Hi-Z. This fault can not be cleared by cycling  $\overline{SD}$ , it is necessary to cycle the PVCC supply.

The minimum differential input voltages required to trigger the DC detect function are shown in table1. The input voltage must keep above the voltage listed in the table for more than 340msec to trigger the DC detect fault. The equivalent class-D output duty of the DC detect threshold is listed in table2.

Table 1. DC Detect Threshold

AV (dB)	Vin (mV, differential)
26	125

Table 2. Output DC Detect Duty (for Either Channel)

PVCC (V)	Output Duty Exceeds
8	20.8%
12	20.8%

- **Thermal protection**

If the internal junction temperature is higher than 160°C, the outputs of loudspeaker drivers will be disabled and at low state. The temperature for AD52058C returning to normal operation is about 135°C. The variation of protected temperature is about 10%. Thermal protection faults are NOT reported on the  $\overline{\text{FAULT}}$  pin.

- **Short-circuit protection**

To protect loudspeaker drivers from over-current damage, AD52058C has built-in short-circuit protection circuit. When the wires connected to loudspeakers are shorted to each other or shorted to VSS or to PVCC, overload detectors may activate. Once one of right and left channel overload detectors are active, the amplifier outputs will enter a Hi-Z state and the protection latch is engaged. The short protection fault is reported on  $\overline{\text{FAULT}}$  pin as a low state. The latch can be cleared by reset  $\overline{\text{SD}}$  or power supply cycling.

The short circuit protection latch can have auto-recovery function by connect the  $\overline{\text{FAULT}}$  pin directly to  $\overline{\text{SD}}$  pin. The latch state will be released after 340msec, and the short protection latch will re-cycle if output overload is detected again.

- **Under-voltage detection**

When the GVDD voltage is lower than 2.8V or the AVCC voltage is lower than 4V, loudspeaker drivers of right/left channel will be disabled and kept at low state. Otherwise, AD52058C return to normal operation.

- **PBTL (Mono) function**

AD52058C provides the application of parallel BTL operation with two outputs of each channel connected directly. If connect INPL and INNl directly to Ground (without capacitors) this sets the device in Mono mode during powerup. Connect OUTPR and OUTNR together for the positive speaker terminal and OUTNL and OUTPL together for the negative pin. Analog input signal is applied to INPR and INNR.

- **Over-voltage protection**

When the AVCC voltage is higher than 15.5V, loudspeaker will be disabled kept at low state. The protection status will be released as AVCC lower than 15V.

● **Power limit function**

- The voltage at PLIMIT pin can be used to limit the power of first gain control amplifier output. Add a resistor divider from GVDD to ground to set the voltage  $V_{PLIMIT}$  at the PLIMIT pin. The voltage  $V_{PLIMIT}$  sets a limit on the output peak-to-peak voltage. PLIMIT is adjustable from 0.3V~2.7V.

For normal BTL operation (Stereo) operation:

$$P_{O@1\%THD} = \frac{\left( V_P \times \left( \frac{R_L}{R_L + 2R_S} \right) \right)^2}{2R_L}$$

$$P_{O@10\%THD} = 1.333 \times P_{O@1\%THD}$$

Where:

$R_S$  is the total series resistance including  $R_{DS(on)}$ , and any resistance in the output filter.

$R_L$  is the load resistance.

$V_P$  is the peak amplitude of the output,  $V_P = 5.0666 \times V_{PLIMIT}$ .

Connect PLIMIT pin to ground (<0.26V) or GVDD (>3V) to disable power limit function. The output variation during power limit feature enable may have +-20% variation due to process window.

Table 3.1 BTL PLIMIT Typical Operation I

Test Conditions	Output $P_O$ (W)	$V_{PLIMIT}$ (V) @ THD+N=10%
PVCC=12V RL=8Ω	3	1.24
	5	1.60
	8	2.02
	9	2.15

Table 3.2 PBTL PLIMIT Typical Operation II

Test Conditions	Output $P_O$ (W)	$V_{PLIMIT}$ (V) @ THD+N=10%
PVCC=12V RL=4Ω	6	1.29
	10	1.67
	12	1.83
	16	2.11

**Application information**

● **Input capacitors (C<sub>in</sub>)**

The performance at low frequency (bass) is affected by the corner frequency (f<sub>c</sub>) of the high-pass filter composed of input resistor (R<sub>in</sub>) and input capacitor (C<sub>in</sub>), determined in equation (2). Typically, a 0.1μF or 1μF ceramic capacitor is suggested for C<sub>in</sub>. The resistance of input resistors is 30kΩ at gain +26dB setting in AD52058C. However, there is 20% variation in input resistance from production variation.

$$f_c = \frac{1}{2\pi R_{in} C_{in}} \text{ (Hz)} \dots\dots\dots (2)$$

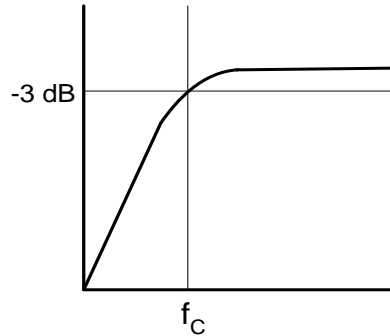

● **Ferrite Bead selection**

If the traces from theAD52058C to speaker are short, the ferrite bead filters can reduce the high frequency emissions to meet FCC requirements. A ferrite bead that has very low impedance at low frequency and high impedance at high frequency (above 1MHz) is recommended. The impedance of the ferrite bead can be used along with a small capacitor with a value around 1000pF to reduce the frequency spectrum of the signal to an acceptable level.

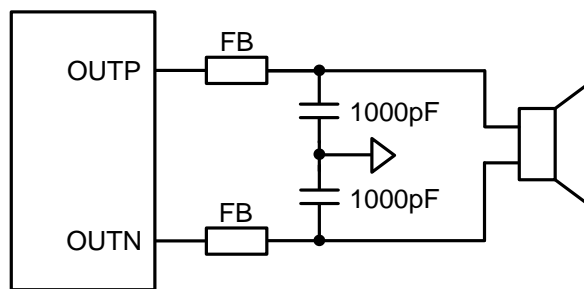

Figure 2. Typical Ferrite Bead Filter

● **Output LC Filter**

If the traces from theAD52058C to speaker are not short, it is recommended to add the output LC filter to eliminate the high frequency emissions. Figure 3 shows the typical output filter for 8Ω speaker with a cut-off frequency of 27 kHz and Figure 4 shows the typical output filter for 4Ω speaker with a cut-off frequency of 27 kHz.

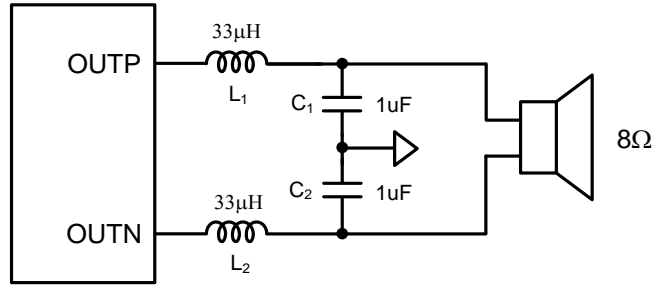

Figure 3. Typical LC Output Filter for 8Ω Speaker

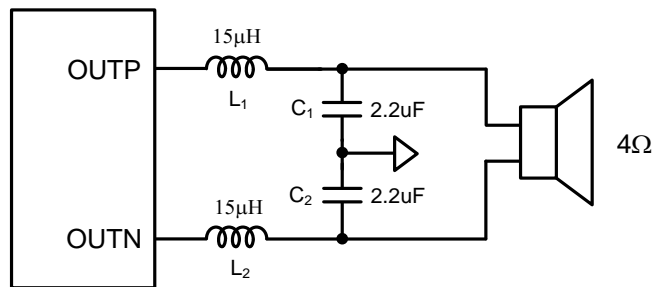

Figure 4. Typical LC Output Filter for 4Ω Speaker

● **Power supply decoupling capacitor (Cs)**

Because of the power loss on the trace between the device and decoupling capacitor, the decoupling capacitor should be placed close to PVCC and PGND to reduce any parasitic resistor or inductor. A low ESR ceramic capacitor, typically 1000pF, is suggested for high frequency noise rejection. For mid-frequency noise filtering, place a capacitor typically 0.1μF or 1μF as close as possible to the device PVCC leads works best. For low frequency noise filtering, a 100μF or greater capacitor (tantalum or electrolytic type) is suggested.

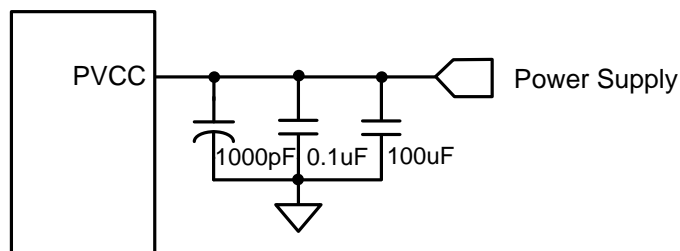
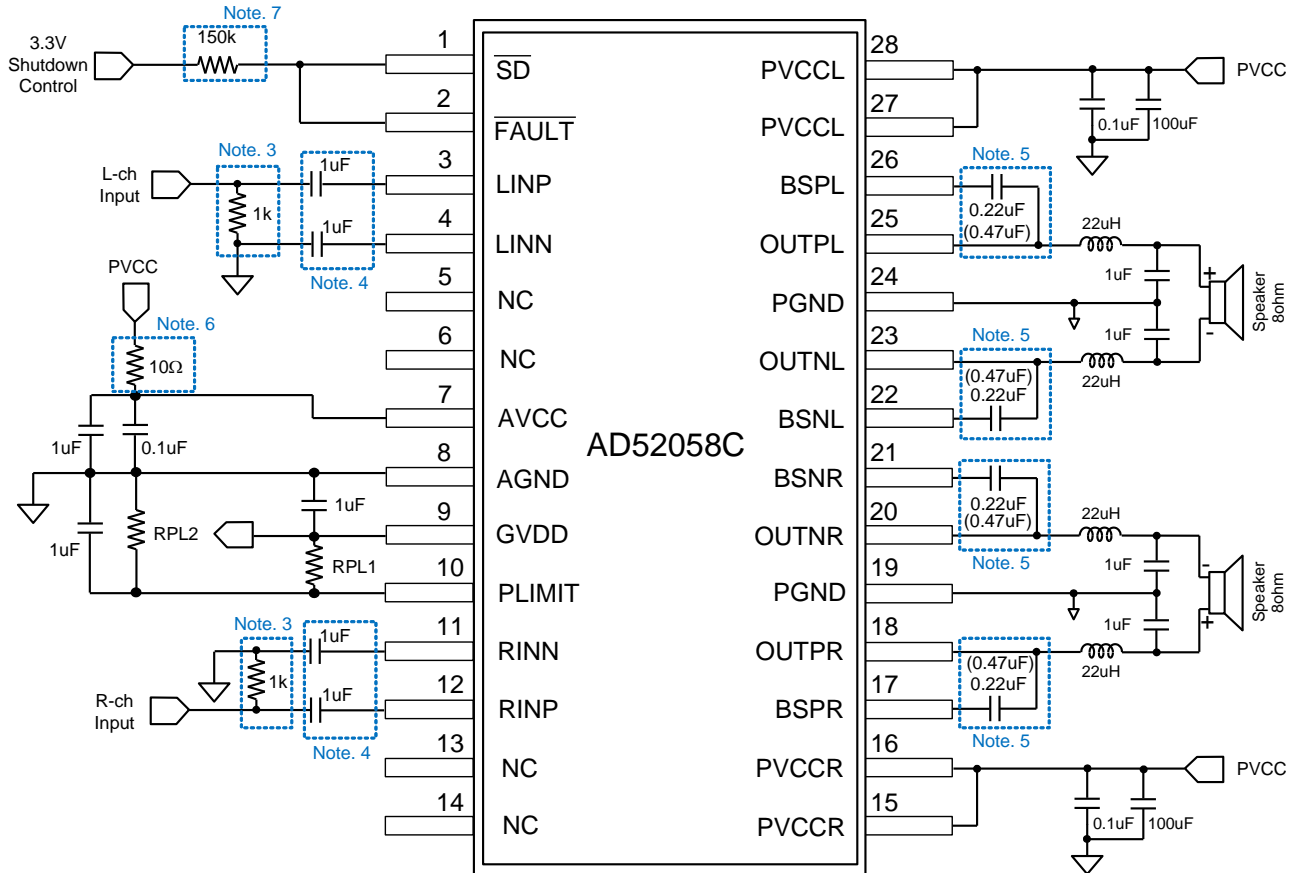

Figure 5. Recommended Power Supply Decoupling Capacitors.

## Application Circuit Example

- Application circuit for BTL (Stereo) mode configuration and Single-Ended Input



**Note 3:** These resistances must be connected to ground, resistance=1Kohm.

**Note 4:** The faster turn-on time 8ms is designed for AD52058C, the pop sound shall be take care with the input resistor ( $R_{in}$ ) added into for input signal attenuation requirement. The longer shutdown release time is necessary if the input resistor ( $R_{in}$ ) is adopted.

**Note 5:** These capacitors should be change to 0.47uF, while the  $PVCC \leq 5V$ .

**Note 6:** The under-voltage threshold for AVCC could be adjusted by  $RAVCC$ .

**Note 7:** The  $R_{Shutdown}$  shall be adjusted depend on "Shutdown Control" voltage, the formula will be

$$followed R_{Shutdown} \geq \frac{(V_{Shutdown} - 2V) \times 210k}{2V} (\Omega).$$



## Application Circuit Example

- Application circuit for parallel BTL (Mono) mode configuration and Single-Ended Input

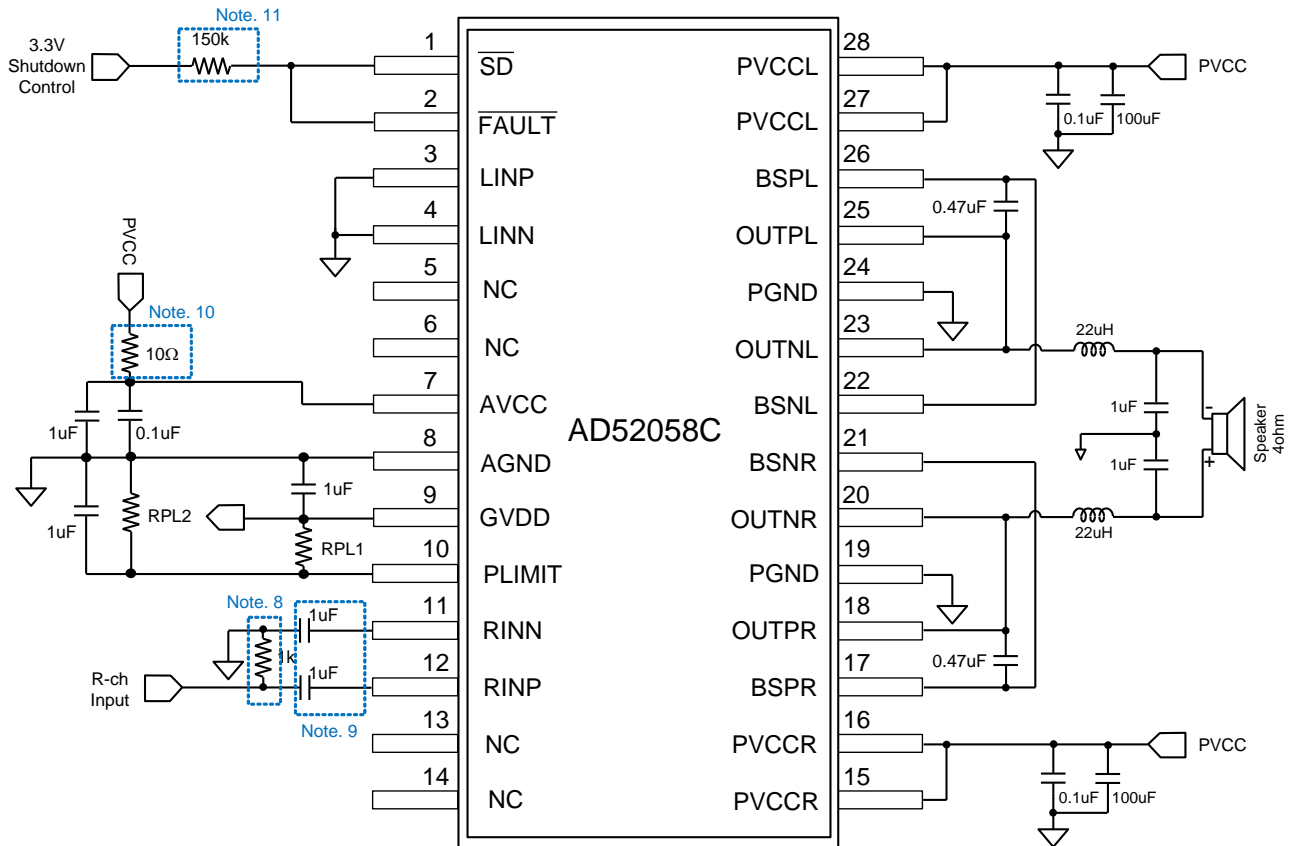

**Note 8:** These resistances must be connected to ground, resistance=1Kohm.

**Note 9:** The faster turn-on time 8ms is designed for AD52058C, the pop sound shall be take care with the input resistor (Rin) added into for input signal attenuation requirement. The longer shutdown release time is necessary if the input resistor (Rin) is adopted.

**Note10:** The under-voltage threshold for AVCC could be adjusted by  $R_{AVCC}$ .

**Note11:** The  $R_{Shutdown}$  shall be adjusted depend on "Shutdown Control" voltage, the formula will be

$$followed R_{Shutdown} \geq \frac{(V_{Shutdown} - 2V) \times 210k}{2V} (\Omega).$$

**Note 12:** Be noted that input should be applied on R-channel only for Mono application.

## Package Dimensions

### ● E-TSSOP 28L

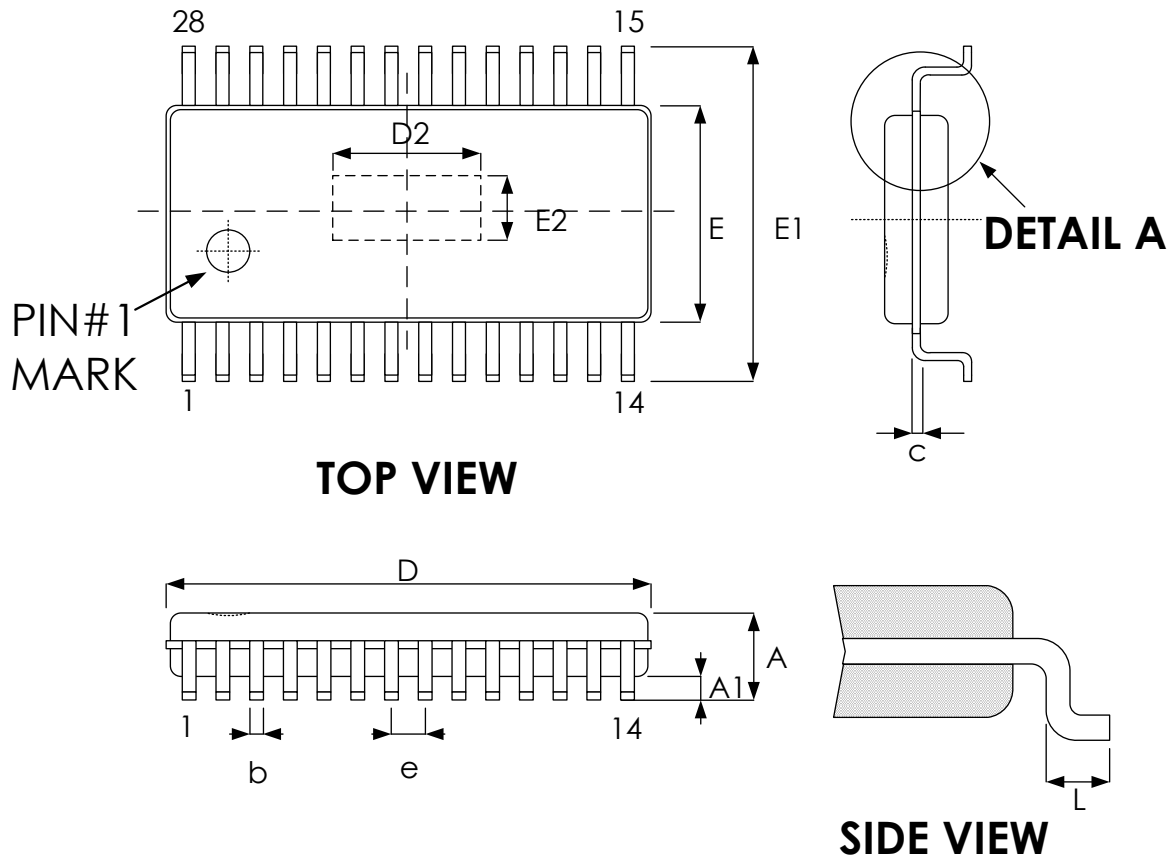

Symbol	Dimension in mm	
	Min	Max
A	--	1.20
A1	0.05	0.15
b	0.19	0.30
c	0.09	0.20
D	9.60	9.80
E	4.30	4.50
E1	6.30	6.50
e	0.65 BSC	
L	0.45	0.75

### Exposed pad

	Dimension in mm	
	Min	Max
D2	5.00	6.40
E2	2.50	2.90

**Revision History**

Revision	Date	Description
0.1	2022.03.21	Initial version.
0.2	2022.03.31	<b>Update</b> AMR of supply voltage from 16V to 20V.
0.3	2022.04.27	Update general electrical characteristics.
1.0	2022.10.04	Remove "Preliminary" & revise to V1.0&& modify Package Dimensions
1.1	2023.02.06	Update Application circuit for Rin require description added into.
1.2	2023.02.16	Update application circuit for FAUTL and SD pin. Update pin description.

**Important Notice**

All rights reserved.

No part of this document may be reproduced or duplicated in any form or by any means without the prior permission of ESMT.

The contents contained in this document are believed to be accurate at the time of publication. ESMT assumes no responsibility for any error in this document, and reserves the right to change the products or specification in this document without notice.

The information contained herein is presented only as a guide or examples for the application of our products. No responsibility is assumed by ESMT for any infringement of patents, copyrights, or other intellectual property rights of third parties which may result from its use. No license, either express, implied or otherwise, is granted under any patents, copyrights or other intellectual property rights of ESMT or others.

Any semiconductor devices may have inherently a certain rate of failure. To minimize risks associated with customer's application, adequate design and operating safeguards against injury, damage, or loss from such failure, should be provided by the customer when making application designs.

ESMT's products are not authorized for use in critical applications such as, but not limited to, life support devices or system, where failure or abnormal operation may directly affect human lives or cause physical injury or property damage. If products described here are to be used for such kinds of application, purchaser must do its own quality assurance testing appropriate to such applications.