

GENERAL DESCRIPTION

The SGM2214 is a low quiescent current and low dropout voltage linear regulator. It is capable of supplying 300mA output current with typical dropout voltage of 235mV. The operating input voltage range is from 2.7V to 16V. The fixed output voltage range is from 1.5V to 5.0V and adjustable output voltage range is from 1.2V to 12V.

Other features include logic-controlled shutdown mode, short-circuit current limit and thermal shutdown protection. The SGM2214 has automatic discharge function to quickly discharge V_{OUT} in the disabled status.

The SGM2214 is available in a Green SOIC-8 package. It operates over an operating temperature range of -40°C to +125°C.

FEATURES

- **Operating Input Voltage Range: 2.7V to 16V**
- **Fixed Outputs of 1.5V, 1.8V, 2.5V, 2.7V, 2.8V, 3.0V, 3.3V and 5.0V**
- **Adjustable Output from 1.2V to 12V**
- **Output Voltage Accuracy: $\pm 1\%$ at +25°C**
- **Low Quiescent Current: 40 μ A (TYP)**
- **Low Dropout Voltage: 235mV (TYP) at 300mA**
- **Power Supply Rejection Ratio: 85dB (TYP) at 1kHz**
- **Current Limiting and Thermal Protection**
- **With Output Automatic Discharge**
- **Open-Drain Power-Good Function**
- **-40°C to +125°C Operating Temperature Range**
- **Available in a Green SOIC-8 Package**

APPLICATIONS

Portable Electronics
 Industrial and Medical Equipment
 Battery-Powered Equipment

TYPICAL APPLICATION

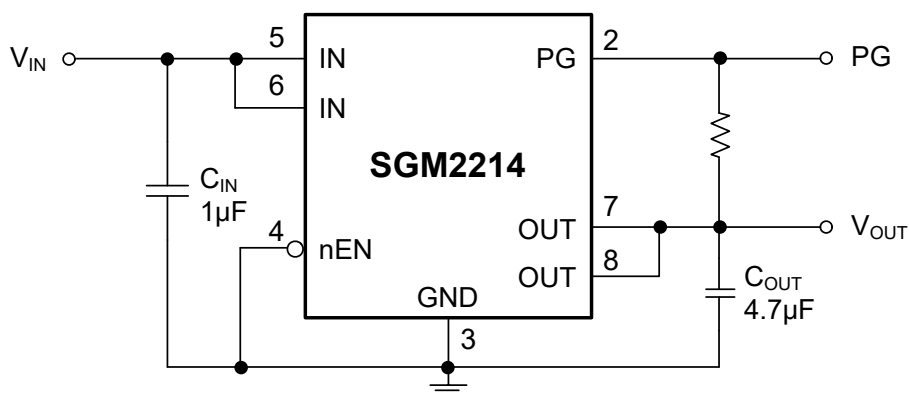

Figure 1. Typical Application Circuit

PACKAGE/ORDERING INFORMATION

MODEL	PACKAGE DESCRIPTION	SPECIFIED TEMPERATURE RANGE	ORDERING NUMBER	PACKAGE MARKING	PACKING OPTION
SGM2214-1.5	SOIC-8	-40°C to +125°C	SGM2214-1.5XS8G/TR	SGM CHEXS8 XXXXX	Tape and Reel, 4000
SGM2214-1.8	SOIC-8	-40°C to +125°C	SGM2214-1.8XS8G/TR	SGM OP2XS8 XXXXX	Tape and Reel, 4000
SGM2214-2.5	SOIC-8	-40°C to +125°C	SGM2214-2.5XS8G/TR	SGM CHFXS8 XXXXX	Tape and Reel, 4000
SGM2214-2.7	SOIC-8	-40°C to +125°C	SGM2214-2.7XS8G/TR	SGM OP3XS8 XXXXX	Tape and Reel, 4000
SGM2214-2.8	SOIC-8	-40°C to +125°C	SGM2214-2.8XS8G/TR	SGM OP4XS8 XXXXX	Tape and Reel, 4000
SGM2214-3.0	SOIC-8	-40°C to +125°C	SGM2214-3.0XS8G/TR	SGM OP5XS8 XXXXX	Tape and Reel, 4000
SGM2214-3.3	SOIC-8	-40°C to +125°C	SGM2214-3.3XS8G/TR	SGM CJXS8 XXXXX	Tape and Reel, 4000
SGM2214-5.0	SOIC-8	-40°C to +125°C	SGM2214-5.0XS8G/TR	SGM CJBXS8 XXXXX	Tape and Reel, 4000
SGM2214-ADJ	SOIC-8	-40°C to +125°C	SGM2214-ADJXS8G/TR	SGM CHBXS8 XXXXX	Tape and Reel, 4000

MARKING INFORMATION

XXXXX = Date Code, Trace Code and Vendor Code.

XXXXX

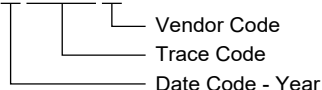

Green (RoHS & HSF): SG Micro Corp defines "Green" to mean Pb-Free (RoHS compatible) and free of halogen substances. If you have additional comments or questions, please contact your SGMICRO representative directly.

ABSOLUTE MAXIMUM RATINGS

Input Voltage Range -0.3V to 22V
Maximum PG Voltage 22V
Output Voltage, V_{OUT} 7V
Enable Voltage Range -0.3V to 22V
Peak Output Current Internally Limited
Package Thermal Resistance
SOIC-8, θ_{JA} 111°C/W
Junction Temperature +150°C
Storage Temperature Range -65°C to +150°C
Lead Temperature (Soldering, 10s) +260°C
ESD Susceptibility
HBM 8000V
CDM 1000V

RECOMMENDED OPERATING CONDITIONS

Input Voltage Range 2.7V to 16V
Output Current Range 0mA to 300mA
Input Effective Capacitance, C_{IN} 0.5µF (MIN)
Output Effective Capacitance, C_{OUT} 2.2µF to 10µF
Operating Junction Temperature Range -40°C to +125°C

OVERSTRESS CAUTION

Stresses beyond those listed in Absolute Maximum Ratings may cause permanent damage to the device. Exposure to absolute maximum rating conditions for extended periods may affect reliability. Functional operation of the device at any conditions beyond those indicated in the Recommended Operating Conditions section is not implied.

ESD SENSITIVITY CAUTION

This integrated circuit can be damaged if ESD protections are not considered carefully. SGMICRO recommends that all integrated circuits be handled with appropriate precautions. Failure to observe proper handling and installation procedures can cause damage. ESD damage can range from subtle performance degradation to complete device failure. Precision integrated circuits may be more susceptible to damage because even small parametric changes could cause the device not to meet the published specifications.

DISCLAIMER

SG Micro Corp reserves the right to make any change in circuit design, or specifications without prior notice.

PIN CONFIGURATIONS

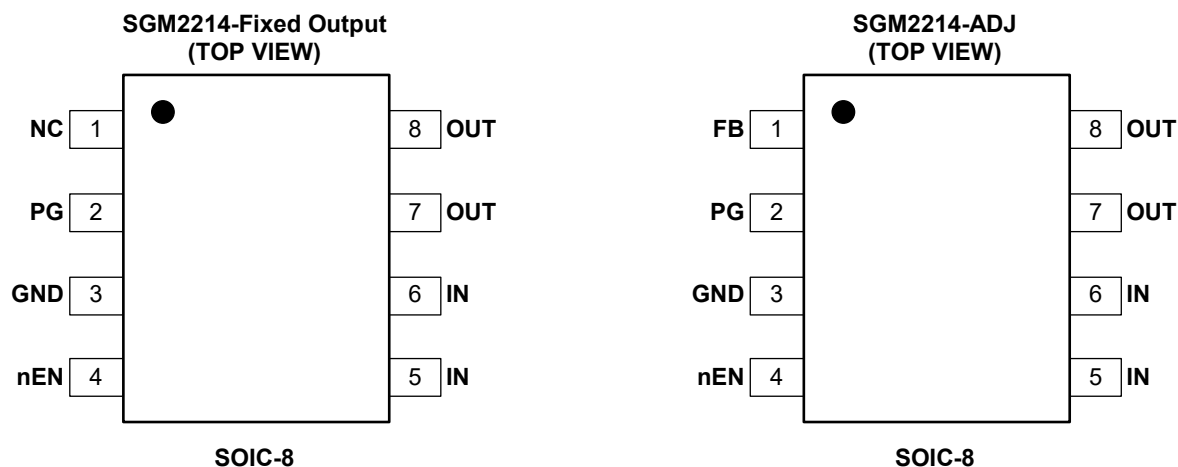

PIN DESCRIPTION

PIN	NAME	FUNCTION
1	NC	No Connection. (fixed voltage version only).
	FB	Feedback Voltage Input Pin (adjustable voltage version only). Connect this pin to the midpoint of an external resistor divider to adjust the output voltage. Place the resistors as close as possible to this pin.
2	PG	Power-Good Output Pin.
3	GND	Ground Pin.
4	nEN	Enable Input Pin. Drive nEN low to turn on the regulator. Drive nEN high to turn off the regulator.
5,6	IN	Input Supply Voltage Pin. It is recommended to use a 1 μ F or larger ceramic capacitor from IN pin to ground to get good power supply decoupling. This ceramic capacitor should be placed as close as possible to IN pin.
7,8	OUT	Regulator Output Pin. It is recommended to use a ceramic capacitor with effective capacitance in the range of 2.2 μ F to 10 μ F to ensure stability. This ceramic capacitor should be placed as close as possible to OUT pin.

ELECTRICAL CHARACTERISTICS

($V_{IN} = V_{OUT(NOM)} + 1V$, $V_{rEN} = 0V$, $I_{OUT} = 1mA$, $C_{IN} = 1\mu F$ and $C_{OUT} = 4.7\mu F$, $T_J = -40^\circ C$ to $+125^\circ C$, typical values are at $T_J = +25^\circ C$, unless otherwise noted.)

PARAMETER	SYMBOL	CONDITIONS	MIN	TYP	MAX	UNITS
Output Voltage	V_{OUT}	$V_{OUT} = \text{ADJ}$, $V_{IN} = 2.7V$ to $16V$, $T_J = +25^\circ C$	1.188	1.2	1.212	V
		$V_{OUT} = \text{ADJ}$, $V_{IN} = 2.7V$ to $16V$	1.182		1.218	
		$V_{OUT} = 1.5V$, $V_{IN} = 2.7V$ to $16V$, $T_J = +25^\circ C$	1.485	1.5	1.515	
		$V_{OUT} = 1.5V$, $V_{IN} = 2.7V$ to $16V$	1.478		1.522	
		$V_{OUT} = 2.5V$, $V_{IN} = 3.5V$ to $16V$, $T_J = +25^\circ C$	2.475	2.5	2.525	
		$V_{OUT} = 2.5V$, $V_{IN} = 3.5V$ to $16V$	2.463		2.537	
		$V_{OUT} = 3.3V$, $V_{IN} = 4.3V$ to $16V$, $T_J = +25^\circ C$	3.267	3.3	3.333	
		$V_{OUT} = 3.3V$, $V_{IN} = 4.3V$ to $16V$	3.251		3.349	
		$V_{OUT} = 5V$, $V_{IN} = 6V$ to $16V$, $T_J = +25^\circ C$	4.95	5	5.05	
		$V_{OUT} = 5V$, $V_{IN} = 6V$ to $16V$	4.925		5.075	
Quiescent Current	I_Q	$V_{rEN} = 0V$, $I_{OUT} = 0\mu A$		40		μA
		$V_{rEN} = 0V$, $I_{OUT} = 0\mu A$, $T_J = -40^\circ C$ to $+125^\circ C$			65	
		$V_{rEN} = 0V$, $I_{OUT} = 50mA$		225		
		$V_{rEN} = 0V$, $I_{OUT} = 50mA$, $T_J = -40^\circ C$ to $+125^\circ C$			320	
		$V_{rEN} = 0V$, $I_{OUT} = 300mA$		640		
		$V_{rEN} = 0V$, $I_{OUT} = 300mA$, $T_J = -40^\circ C$ to $+125^\circ C$			775	
Output Voltage Line Regulation ⁽¹⁾	$\frac{\Delta V_{OUT}}{\Delta V_{OUT} \times V_{OUT}}$	$V_{IN} = (V_{OUT(NOM)} + 1V)$ to $16V$, $I_{OUT} = 1mA$		0.001		%V
		$V_{IN} = (V_{OUT(NOM)} + 1V)$ to $16V$, $I_{OUT} = 1mA$, $T_J = -40^\circ C$ to $+125^\circ C$			0.006	
Load Regulation	ΔV_{OUT}	$I_{OUT} = 10\mu A$ to $300mA$		0.02		%mA
		$I_{OUT} = 10\mu A$ to $300mA$, $T_J = -40^\circ C$ to $+125^\circ C$			0.5	
Output Voltage Noise	e_n	$V_{OUT} = 3.3V$, $I_{OUT} = 10mA$, $BW = 10Hz$ to $100kHz$		50		μV_{RMS}
Output Current Limit	I_{LIMIT}	$V_{OUT} = 90\%V_{OUT(NOM)}$, $T_J = +25^\circ C$	500	960		mA
Enable Input High Voltage	V_{IH}	$V_{IN} = 2.7V$ to $16V$, $T_J = +25^\circ C$	1.5			V
Enable Input Low Voltage	V_{IL}	$V_{IN} = 2.7V$ to $16V$, $T_J = +25^\circ C$			0.4	
Standby Current		$V_{rEN} = V_{IN}$, $T_J = +25^\circ C$			2.5	μA
		$V_{rEN} = V_{IN}$			3	
Power Supply Rejection Ratio	PSRR	$I_{OUT} = 10mA$, $f = 1kHz$		85		dB
Dropout Voltage ⁽²⁾	V_{DROP}	$V_{OUT} = 2.5V$, $V_{IN} = 3.5V$, $I_{OUT} = 300mA$		275		mV
		$V_{OUT} = 2.5V$, $V_{IN} = 3.5V$, $I_{OUT} = 300mA$, $T_J = -40^\circ C$ to $+125^\circ C$			460	
		$V_{OUT} = 3.3V$, $V_{IN} = 4.3V$, $I_{OUT} = 300mA$		235		
		$V_{OUT} = 3.3V$, $V_{IN} = 4.3V$, $I_{OUT} = 300mA$, $T_J = -40^\circ C$ to $+125^\circ C$			410	
		$V_{OUT} = 5V$, $V_{IN} = 6V$, $I_{OUT} = 300mA$		195		
		$V_{OUT} = 5V$, $V_{IN} = 6V$, $I_{OUT} = 300mA$, $T_J = -40^\circ C$ to $+125^\circ C$			340	

NOTES:

- Minimum IN operating voltage is 2.7V or $V_{OUT(NOM)} + 1V$, whichever is greater. Maximum IN operating voltage is 16V.
- The dropout voltage is defined as the difference between V_{IN} and V_{OUT} when V_{OUT} falls to $95\% \times V_{OUT(NOM)}$.

ELECTRICAL CHARACTERISTICS (continued)

($V_{IN} = V_{OUT(NOM)} + 1V$, $V_{rEN} = 0V$, $I_{OUT} = 1mA$, $C_{IN} = 1\mu F$ and $C_{OUT} = 4.7\mu F$, $T_J = -40^\circ C$ to $+125^\circ C$, typical values are at $T_J = +25^\circ C$, unless otherwise noted.)

PARAMETER	SYMBOL	CONDITIONS	MIN	TYP	MAX	UNITS
nEN Pin Input Current	I_{rENL}	$V_{rEN} = 0V$, $T_J = -40^\circ C$ to $+125^\circ C$	-1	0	1	μA
	I_{rENH}	$V_{rEN} = V_{IN}$	-1		1	
Thermal Shutdown Temperature	T_{SHDN}			150		$^\circ C$
Thermal Shutdown Hysteresis	ΔT_{SHDN}			20		$^\circ C$
Power-Good						
Minimum Input Voltage for Valid PG		$I_{OUT} = 300\mu A$		1.2		V
Trip Threshold Voltage		V_{OUT} decreasing, $T_J = +25^\circ C$	92		98	$\%V_{OUT}$
Hysteresis Voltage		Measured at V_{OUT}		0.75		$\%V_{OUT}$
Output Low Voltage		$V_{IN} = 2.7V$, $I_{OUT(PG)} = 1mA$		0.12		V
Leakage Current		$V_{(PG)} = 5V$, $T_J = +25^\circ C$			1	μA

TYPICAL PERFORMANCE CHARACTERISTICS

$T_J = +25^\circ\text{C}$, $V_{IN} = 4.3\text{V}$, $V_{OUT} = 3.3\text{V}$, $I_{OUT} = 300\text{mA}$, $C_{IN} = 1\mu\text{F}$ and $C_{OUT} = 4.7\mu\text{F}$, unless otherwise noted.

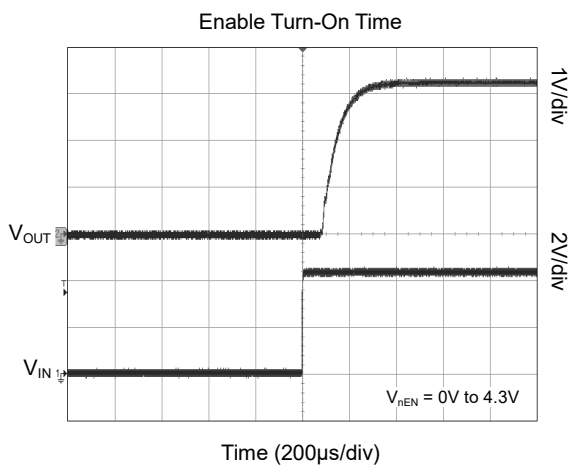
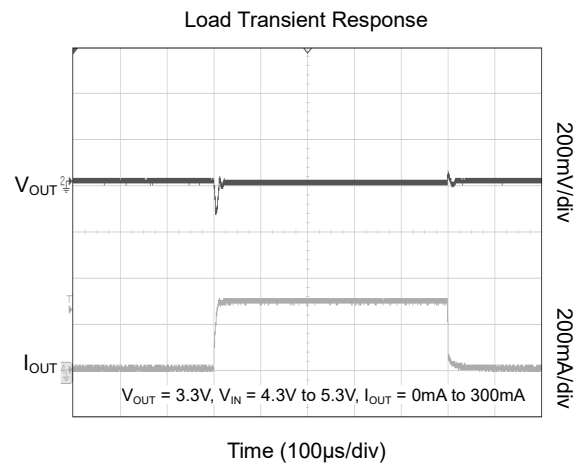
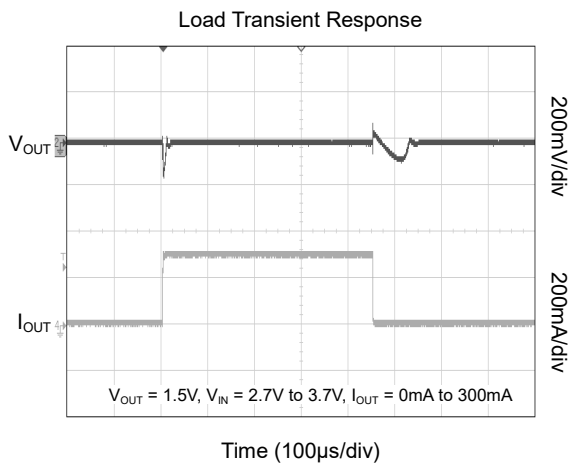
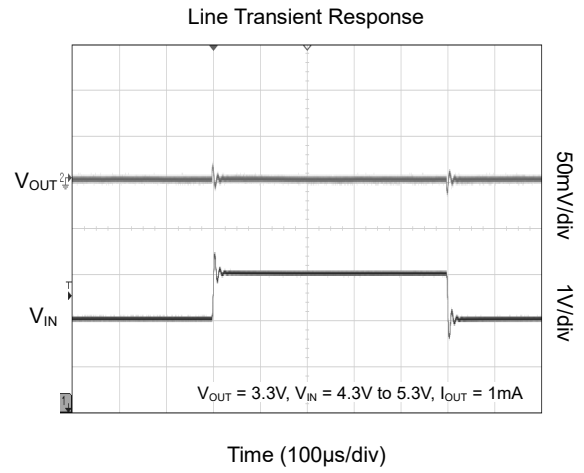
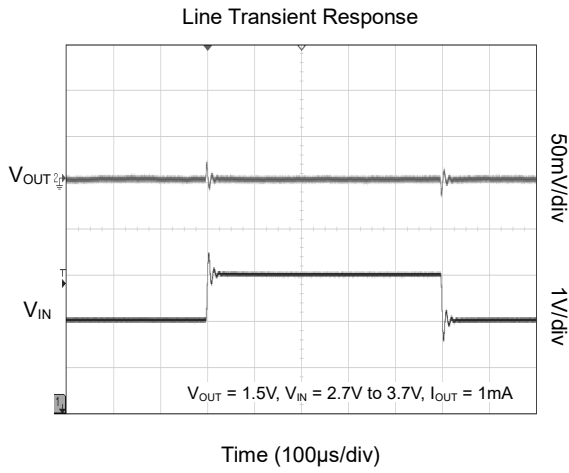

TYPICAL PERFORMANCE CHARACTERISTICS (continued)

$T_J = +25^\circ\text{C}$, $V_{IN} = 4.3\text{V}$, $V_{OUT} = 3.3\text{V}$, $I_{OUT} = 300\text{mA}$, $C_{IN} = 1\mu\text{F}$ and $C_{OUT} = 4.7\mu\text{F}$, unless otherwise noted.

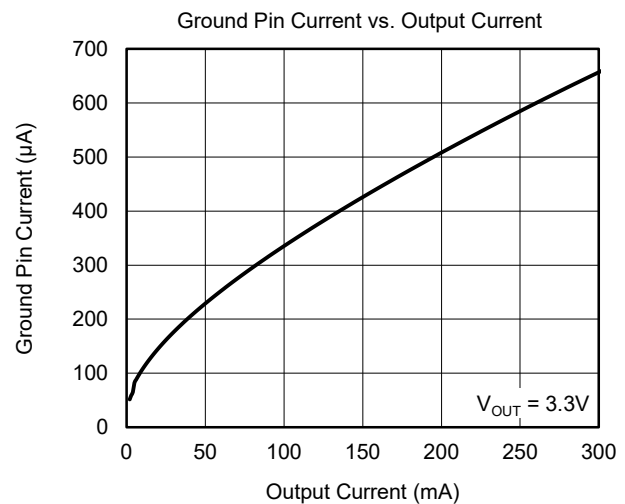
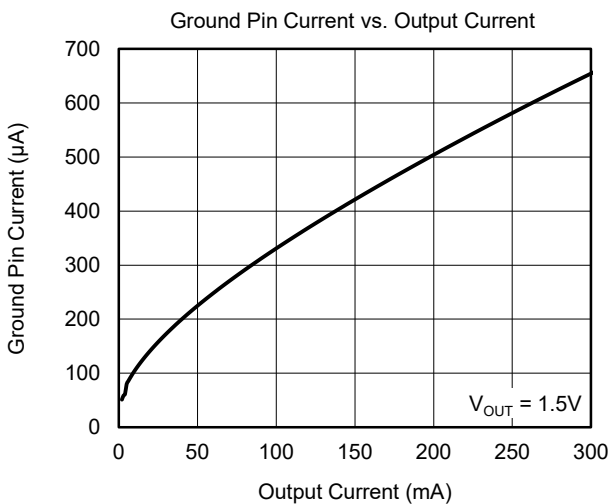
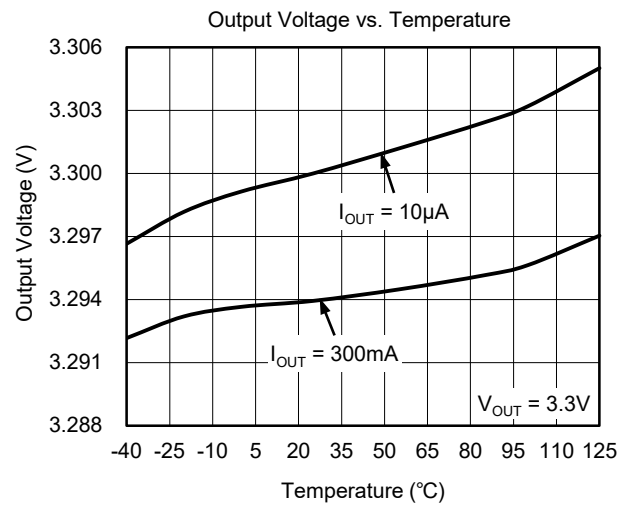
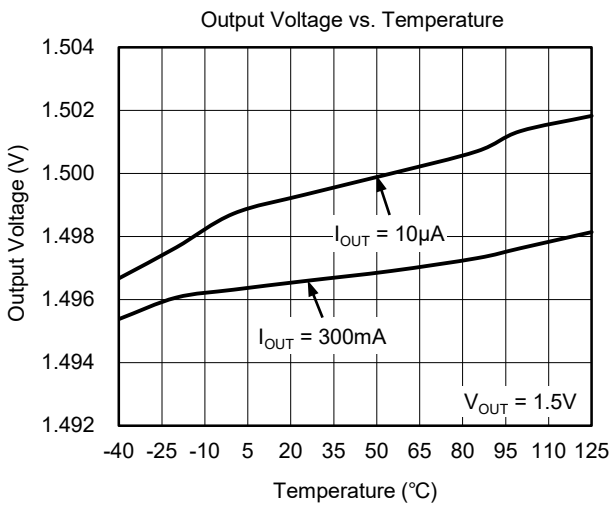
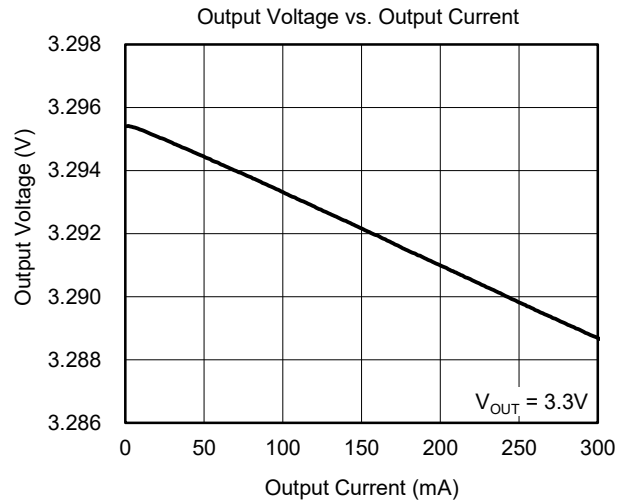
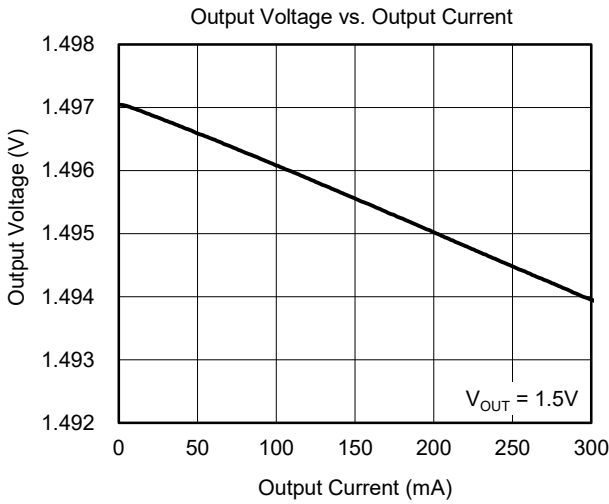

TYPICAL PERFORMANCE CHARACTERISTICS (continued)

$T_J = +25^\circ\text{C}$, $V_{IN} = 4.3\text{V}$, $V_{OUT} = 3.3\text{V}$, $I_{OUT} = 300\text{mA}$, $C_{IN} = 1\mu\text{F}$ and $C_{OUT} = 4.7\mu\text{F}$, unless otherwise noted.

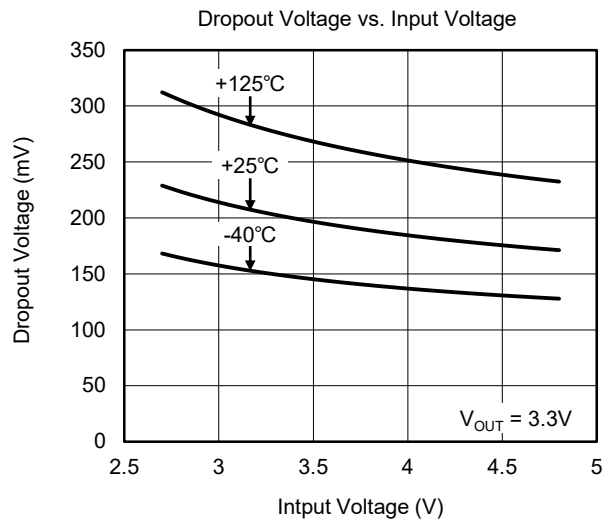
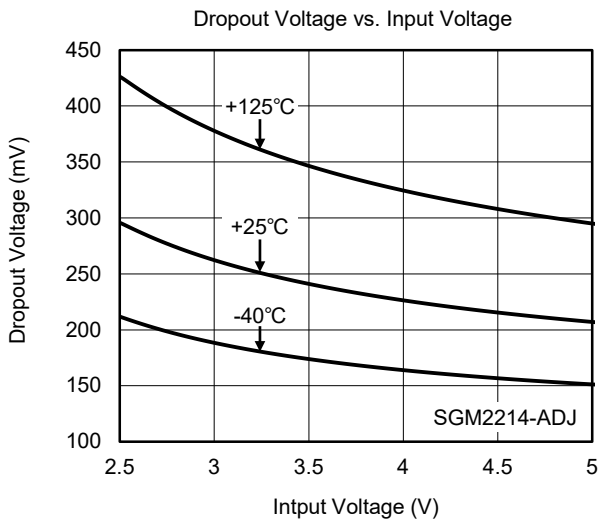
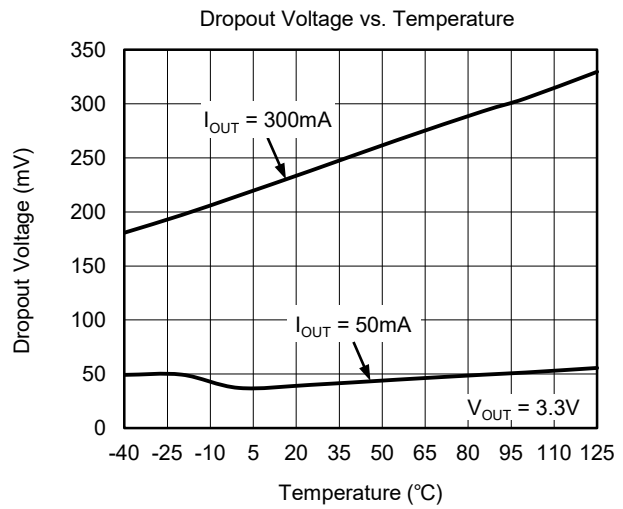
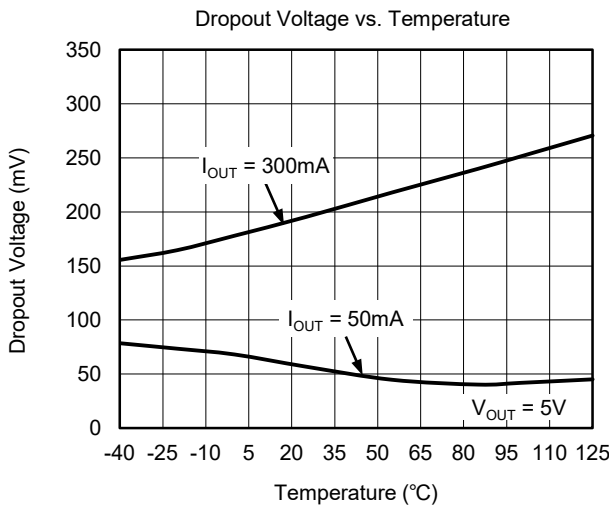
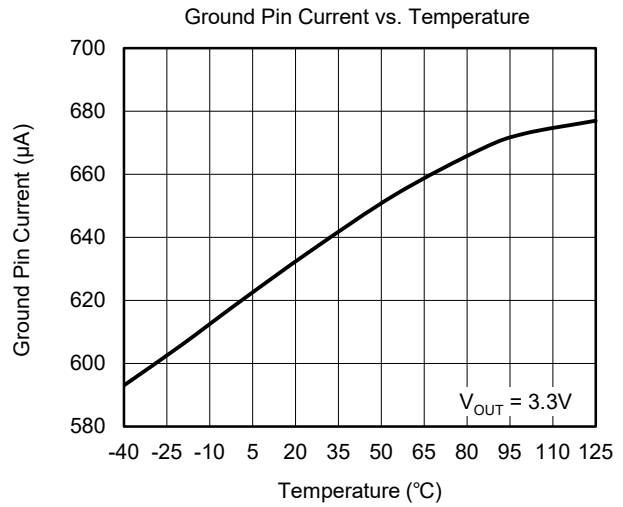
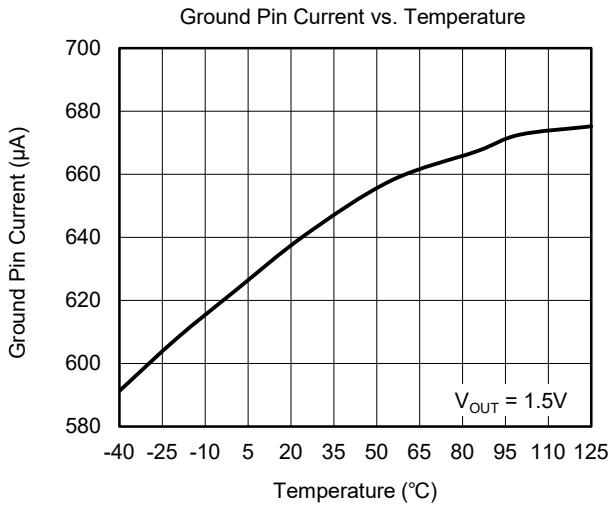

TYPICAL PERFORMANCE CHARACTERISTICS (continued)

$T_J = +25^\circ\text{C}$, $V_{IN} = 4.3\text{V}$, $V_{OUT} = 3.3\text{V}$, $I_{OUT} = 300\text{mA}$, $C_{IN} = 1\mu\text{F}$ and $C_{OUT} = 4.7\mu\text{F}$, unless otherwise noted.

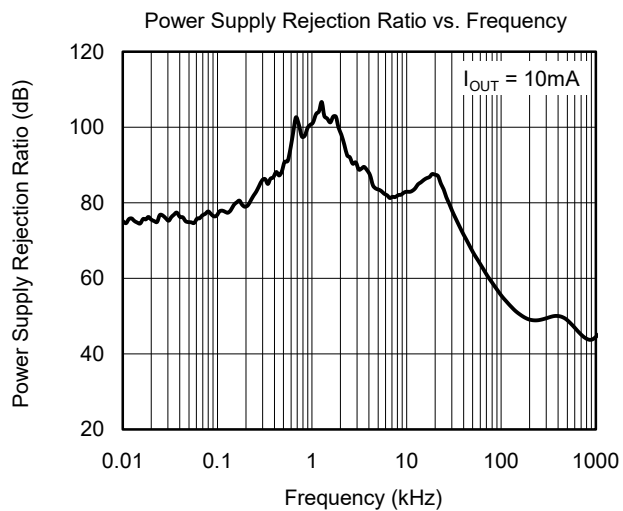
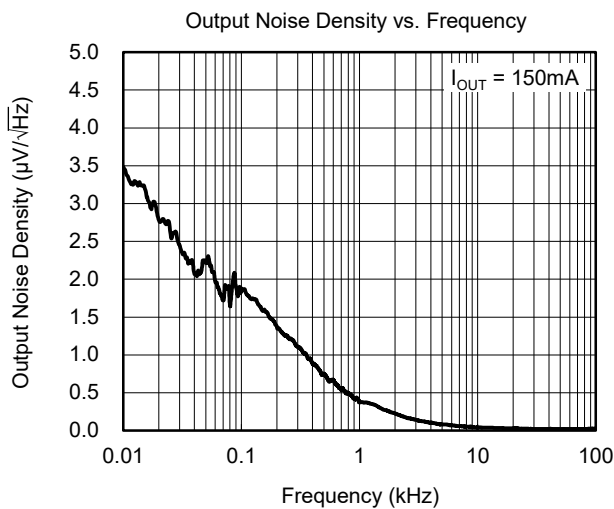
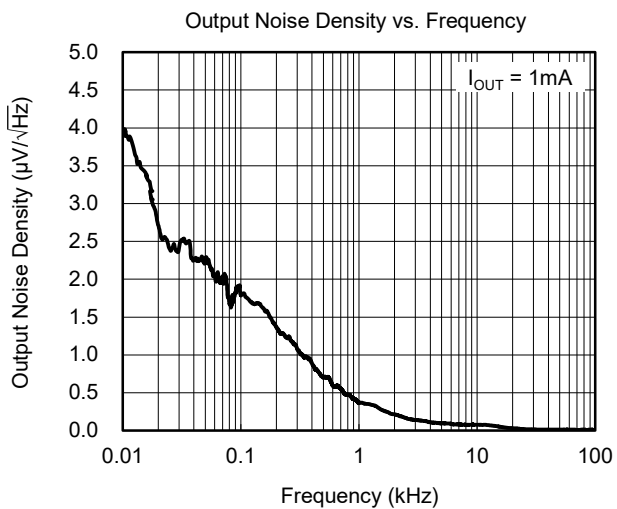

FUNCTIONAL BLOCK DIAGRAMS

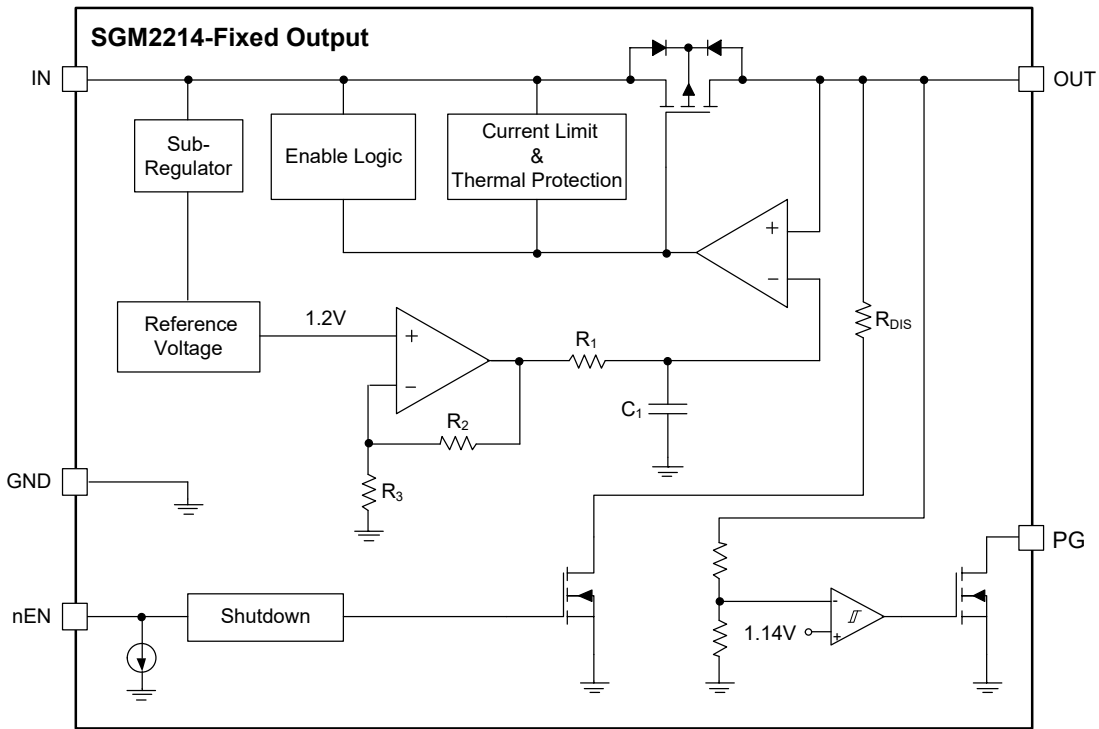

Figure 2. Fixed Version Block Diagram

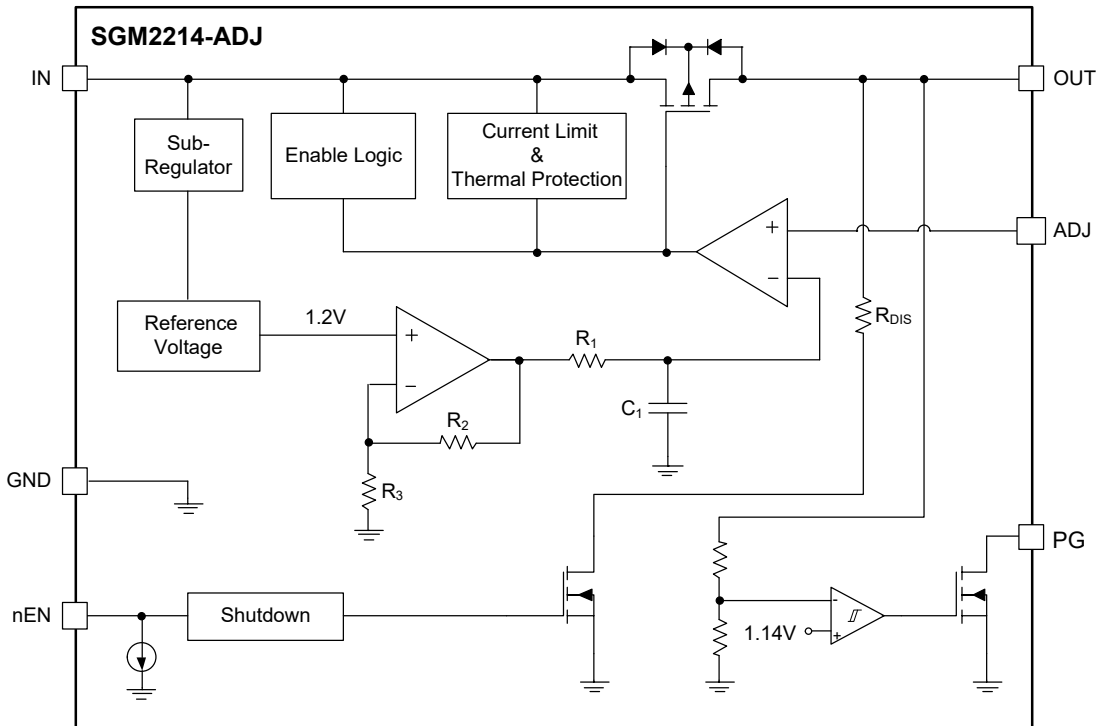

Figure 3. Adjustable Version Block Diagram

APPLICATION INFORMATION

The SGM2214 is a low quiescent current and low dropout voltage LDO and provides 300mA output current. These features make the device a reliable solution to solve many challenging problems in the generation of clean and accurate power supply. The high performance also makes the SGM2214 useful in a variety of applications. The SGM2214 provides protection functions for output overload, output short-circuit condition and overheating.

The SGM2214 provides a nEN pin as an external chip enable control to enable/disable the device.

Input Capacitor Selection (C_{IN})

The input decoupling capacitor should be placed as close as possible to the IN pin for ensuring the device stability. 1µF or larger X7R or X5R ceramic capacitor is selected to get good dynamic performance.

When V_{IN} is required to provide large current instantaneously, a large effective input capacitor is required. Multiple input capacitors can limit the input tracking inductance. Adding more input capacitors is available to restrict the ringing and to keep it below the device absolute maximum ratings.

Output Capacitor Selection (C_{OUT})

The output capacitor should be placed as close as possible to the OUT pin. 4.7µF or larger X7R or X5R ceramic capacitor is selected to get good dynamic performance. The minimum effective capacitance of C_{OUT} that SGM2214 can remain stable is 2.2µF. For ceramic capacitor, temperature, DC bias and package size will change the effective capacitance, so enough margin of C_{OUT} must be considered in design. Additionally, C_{OUT} with larger capacitance and lower ESR will help increase the high frequency PSRR and improve the load transient response.

Adjustable Regulator

The output voltage of the SGM2214-ADJ can be adjusted from 1.2V to 12V. The FB pin will be connected

to two external resistors as shown in Figure 4. Choose R₂ = 169kΩ to maintain a 7mA load. The output voltage is determined by the following equation:

$$V_{OUT} = V_{FB} \times \left(1 + \frac{R_1}{R_2} \right) \tag{1}$$

where:

V_{OUT} is output voltage and V_{FB} is the internal voltage reference, V_{FB} = 1.2V.

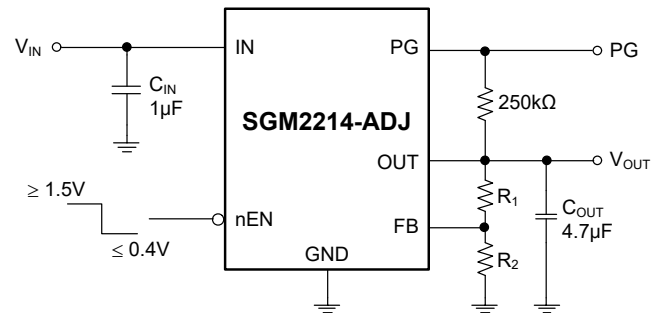

Figure 4. Adjustable Output Voltage Application

No-Load Stability

The SGM2214 can maintain stability without output load (except internal voltage divider).

Output Current Limit and Short-Circuit Protection

When overload events happen, the output current is internally limited to 960mA (TYP). When the OUT pin is shorted to ground, the short-circuit protection will limit the output current.

Thermal Shutdown

The SGM2214 can detect the temperature of die. When the die temperature exceeds the threshold value of thermal shutdown, the SGM2214 will be in shutdown state and it will remain in this state until the die temperature decreases to +130°C.

REVISION HISTORY

NOTE: Page numbers for previous revisions may differ from page numbers in the current version.

Changes from Original (MARCH 2021) to REV.A	Page
Changed from product preview to production data.....	All

PACKAGE OUTLINE DIMENSIONS

SOIC-8

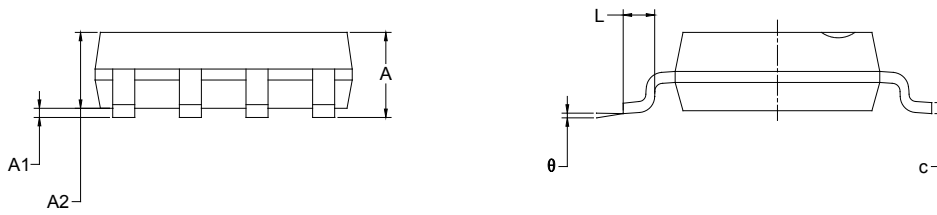
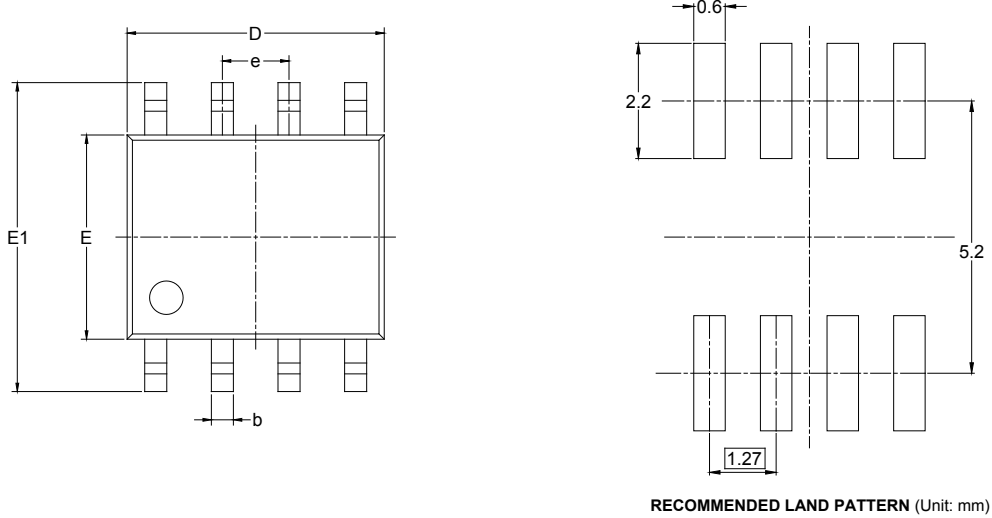

Symbol	Dimensions In Millimeters		Dimensions In Inches	
	MIN	MAX	MIN	MAX
A	1.350	1.750	0.053	0.069
A1	0.100	0.250	0.004	0.010
A2	1.350	1.550	0.053	0.061
b	0.330	0.510	0.013	0.020
c	0.170	0.250	0.006	0.010
D	4.700	5.100	0.185	0.200
E	3.800	4.000	0.150	0.157
E1	5.800	6.200	0.228	0.244
e	1.27 BSC		0.050 BSC	
L	0.400	1.270	0.016	0.050
θ	0°	8°	0°	8°

PACKAGE INFORMATION

TAPE AND REEL INFORMATION

REEL DIMENSIONS



TAPE DIMENSIONS



NOTE: The picture is only for reference. Please make the object as the standard.

KEY PARAMETER LIST OF TAPE AND REEL

Package Type	Reel Diameter	Reel Width W1 (mm)	A0 (mm)	B0 (mm)	K0 (mm)	P0 (mm)	P1 (mm)	P2 (mm)	W (mm)	Pin1 Quadrant
SOIC-8	13"	12.4	6.40	5.40	2.10	4.0	8.0	2.0	12.0	Q1

000001

PACKAGE INFORMATION

CARTON BOX DIMENSIONS



NOTE: The picture is only for reference. Please make the object as the standard.

KEY PARAMETER LIST OF CARTON BOX

Reel Type	Length (mm)	Width (mm)	Height (mm)	Pizza/Carton
13"	386	280	370	5

DD0002